

About this Manual

We've added this manual to the Agilent website in an effort to help you support your product. This manual is the best copy we could find; it may be incomplete or contain dated information. If we find a more recent copy in the future, we will add it to the Agilent website.

Support for Your Product

Agilent no longer sells or supports this product. Our service centers may be able to perform calibration if no repair parts are needed, but no other support from Agilent is available. You will find any other available product information on the Agilent Test & Measurement website, www.tm.agilent.com.

HP References in this Manual

This manual may contain references to HP or Hewlett-Packard. Please note that Hewlett-Packard's former test and measurement, semiconductor products and chemical analysis businesses are now part of Agilent Technologies. We have made no changes to this manual copy. In other documentation, to reduce potential confusion, the only change to product numbers and names has been in the company name prefix: where a product number/name was HP XXXX the current name/number is now Agilent XXXX. For example, model number HP8648A is now model number Agilent 8648A.

Reference Manual

**HP E4900A
Spectrum
Monitoring
System**



HP Part No. E4900-90010
Printed in USA October 1994

Notice The information contained in this document is subject to change without notice. Hewlett-Packard makes no warranty of any kind with regard to this material, including but not limited to, the implied warranties of merchantability and fitness for a particular purpose. Hewlett-Packard shall not be liable for errors contained herein or for incidental or consequential damages in connection with the furnishing, performance, or use of this material.

© Copyright SAT Corporation 1994.

© Copyright Hewlett-Packard Company 1995.

All Rights Reserved. Reproduction, adaptation, or translation without prior written permission is prohibited, except as allowed under the copyright laws.

Hewlett-Packard Company

1400 Fountaingrove Parkway, Santa Rosa CA 95403-1799, USA

CONTENTS

- PREFACE..... XI**

- 1 SYSTEM OVERVIEW..... 1-1**
 - Spectrum Monitoring System Overview.....1-2**

 - System Configurations1-3**
 - Monitoring Site Configuration.....1-3
 - Optional Central Site Configuration.....1-5

- 2 RECEIVING AND INSTALLING YOUR SYSTEM..... 2-1**
 - Receiving And Installing Your Monitoring System2-1**
 - Unpacking and Initial Inspection2-1

 - Preparation For Use.....2-4**
 - Power Requirements2-4
 - Operating Environment.....2-4
 - Storage Environment2-4
 - Work Surface Requirement2-5
 - Floor Space and Work Surface Requirement2-5

 - Installing Your Monitoring System.....2-5**
 - Installing The Optional ICOM AH-7000 Antenna.....2-10
 - Installing The HP 8591E Spectrum Analyzer2-11
 - Installing the Monitoring Site Cabinet Assembly2-11
 - Installing The Hewlett-Packard PC.....2-12

- 3 ACTIVATING YOUR SYSTEM..... 3-1**
 - Power Up.....3-1**

 - Starting Your Monitoring Site3-2**
 - Starting Your Monitoring System.....3-2
 - System Verification Test3-3

 - Terminating And Shutting Down Your Monitoring System3-4**
 - Shutting-Down.....3-4

- 4 INTRODUCING YOUR MONITORING SYSTEM 4-1**
 - Signal Logging with the HP E4900.....4-1**

 - Carrier Measurements with the HP E49004-2**

Occupancy Measurements with the HP E4900	4-2
Statistical Measurements with the HP E4900	4-2
System Capabilities	4-3
Spectrum Analyzer Window	4-3
Multiple Band Window	4-4
Automatic Monitoring	4-5
Monitoring Plans.....	4-5
Scheduled Monitoring.....	4-5
Report Generation	4-6
Automatic Switching Between Antennas	4-6
Path Correction	4-6
Remote Site Operation	4-7
5 OPERATING YOUR SYSTEM	5-1
Operating The Spectrum Analyzer Window	5-1
Opening the Spectrum Analyzer Window	5-1
Setting and Modifying Monitoring Band Frequencies	5-3
Setting Or Modifying the Resolution and Video Bandwidth	5-4
Setting the Reference Level	5-4
Setting Attenuation	5-5
Setting A Threshold	5-5
Setting Spectrum Analyzer Sweep Time	5-6
Defining A Monitoring Profile.....	5-7
Selecting RF Path and Applying Path Gain Correction.....	5-9
Saving Band Definitions and Monitoring Settings.....	5-9
Recalling A Previously Defined Frequency Band.....	5-10
Performing Carrier Measurements Using the Marker.....	5-10
Using the Spectrogram	5-11
Using the Spectrogram Marker.....	5-13
Manual Receiver Handoff.....	5-13
Operating the Spectrum Analyzer in Raw Mode.....	5-14
Closing the Spectrum Analyzer Window	5-15
Operating the Receiver and Recorder Manually	5-15
Receiver Control	5-15
Recording Control	5-17
Playback Control	5-18
Using the Multiple Band Window	5-18
Opening the Multiple Band Window:	5-19
Display Optimization.....	5-21
Using the Spectrogram in Multiple Band Window.....	5-21
Using the Marker Option.....	5-21
Controlling the Multiple Band Window.....	5-23

Viewing Archived Traces	5-23
6 MONITORING UNDER A PLAN	6-1
Creating A Monitoring Plan.....	6-1
Defining Frequency Bands	6-1
Setting Start/ Stop Frequencies For Channelized Measurements.....	6-3
Defining Measurements	6-4
Setting Up Signal Logging Measurements.....	6-4
Setting Up Carrier Measurements.....	6-7
Setting Carrier Measurement Alarms	6-11
Setting Up Occupancy Measurements.....	6-13
Setting Up Statistical Measurements	6-16
Signal Masks	6-18
Selecting And Activating A Mask.....	6-18
Invoking Masking For a Specific Measurement.....	6-19
Assembling Your Monitoring Plan.....	6-19
7 RUNNING AND CONTROLLING YOUR MONITORING PLAN	7-1
Running Your Monitoring Plan Manually.....	7-1
Display Management.....	7-2
Setting Up And Running Your Monitoring Schedule	7-4
Viewing the SA Window when a Schedule is Active or Pending	7-5
Running a Monitoring Plan Manually while Scheduler is Active or Pending.....	7-5
Viewing Multiple Band Windows when Scheduler is Active or Pending.....	7-6
8 GENERATING REPORTS	8-1
Viewing Reports	8-1
Alarm Log Reports.....	8-1
Occupancy Measurements Reports	8-3
Viewing Occupancy Reports.....	8-3
Viewing Carrier Reports.....	8-5
Viewing Signal Log Reports	8-7

Viewing Statistical Measurements Reports	8-8
Viewing Monitoring Plan Reports.....	8-13
Viewing Saved Reports.....	8-14
Managing Disk Space.....	8-14
Archiving Reports	8-14
9 EXPORTING DATA.....	9-1
Exporting Monitoring Plans.....	9-1
Exporting Band Definitions	9-2
Exporting Occupancy Data	9-2
Exporting Signal Log Data	9-3
Exporting Carrier Measurement Data	9-4
Exporting Statistical Measurement Data.....	9-5
Viewing Exported Data In A Spreadsheet Program.....	9-7
10 HP E4900 DATABASE FILE MOVEMENT UTILITIES.....	10-1
Performing Setup Backup and Restoration.....	10-1
Archiving And Restoring Archived Data.....	10-2
11 USING YOUR SMS REMOTE SOFTWARE.....	11-1
Starting Your Remote Software	11-1
Starting Carbon Copy.....	11-2
Configuring the Central Site.....	11-8
Connecting to and Controlling a Remote Site.....	11-9
Configuring the Phone Book.....	11-9
Calling the Remote Site	11-11
Setting the Reboot on Disconnect Option.....	11-12
Starting the SMS Program.....	11-14
Using the SMS Program Remotely.....	11-14
Performing Remote File Management	11-14
Generating Reports	11-14
Transferring Files from the Remote Site to a Central Site	11-15
Viewing Reports with SMS Software.....	11-21
Viewing Reports without the SMS Software	11-21
Remote Drive Access	11-22

Chatting with a Remote Site User	11-25
Using the Remote Clipboard	11-27
Disconnecting from a Remote Site and Exiting	11-28
12 SYSTEM ADMINISTRATION	12-1
Your Standalone/Remote Monitoring Site	12-1
Administrative Operations for E4900 Software.....	12-1
System Initialization Files for E4900 Software	12-2
E4900 Initialization Files in the WINDOWS Directory.....	12-3
E4900 Initialization Files in the C:\SIGMON\CONFIG Directory.....	12-9
13 TROUBLESHOOTING	13-1
If You Have a Problem	13-1
Seeking Help.....	13-1
Checking Hardware.....	13-1
Checking Software.....	13-2
Verifying the HP3488 Switch	13-2
Verifying the Receiver	13-3
Verifying the Recorder	13-4
Calling HP Sales and Service Offices	13-4
Additional Support Services	13-4
Using Online Help.....	13-4
Help Contets.....	13-5
FAX Support Line.....	13-5
14 TECHNICAL SPECIFICATIONS	14-1
System Capabilities	14-1
Measurement	14-1
Band Definition.....	14-2
RF Path Management.....	14-2
Multiple Band Window.....	14-2
Spectrum Analyzer Control.....	14-5
Demodulation and Recording.....	14-5
Signal Logging.....	14-5
Carrier Measurements.....	14-6
Spectral Occupancy.....	14-8
Statistical Measurements.....	14-10

Coordination	14-10
Task Scheduling.....	14-10
Multitasking.....	14-10
Alarms	14-12
Remote Operation.....	14-13
Reports	14-13
Standard Reports	14-13
Custom Reports.....	14-13
System Specifications	14-15
HP E4900A 1.8 GHz Spectrum Monitoring System.....	14-15
HP E4901A 2.9 GHz Spectrum Monitoring System.....	14-17
HP E4902A 26.5 GHz Spectrum Monitoring System.....	14-18
HP E4903A Central Site Controller	14-20
Characteristics of Option 011 omnidirectional discone antenna.....	14-20
Definition of Terms.....	14-20
Post Sales Service	14-22
Hardware Warranty.....	14-22
Application Support.....	14-22
Feature Summary Table	14-23

Preface

Safety and Regulatory Statements

The following safety and regulatory statements apply to the measurement system only (E4900 Option 001 and Option 003). Similar statements regarding the computer portion of the system may be found in its documentation. Consult the documentation accompanying individual pieces of equipment in systems not delivered preconfigured in a rack for their individual safety and regulatory statements.

General System Information

Dimensions

E4900 option 001 and 003
60 cm (w) x 90.5 cm (d) x 112 cm (h)
(23-3/4 in x 36 in x 44-1/4 in)

Weight

The potential weight of a fully loaded system is 146 kg (318 pounds).

Declaration of
Conformity

DECLARATION OF CONFORMITY

according to ISO/IEC Guide 22 and EN 45014

Manufacturer's Name: Hewlett-Packard Co.

Manufacturer's Address: Santa Rosa Systems Division
1400 Fountaingrove Parkway
Santa Rosa, CA 95403-1799
USA

declares that the product

Product Name: Spectrum Monitoring System

Model Number: HP E4900/1/2/3A

Product Options: This declaration covers all options of the
above product.

conforms to the following Product specifications:

Safety: IEC 348:1978/HD 401 S1:1981
CAN/CSA-C22.2 No. 231 (Series M-89)

EMC: CISPR 11:1990/EN 55011:1991 Group 1, Class A
IEC 801-2:1984/EN 50082-1:1992 4 kV CD, 8 kV AD
IEC 801-3:1984/EN 50082-1:1992 3 V/m, 27-500 MHz
IEC 801-4:1988/EN 50082-1:1992 0.5 kV Sig. Lines, 1 kV Power Lines

Supplementary Information:

The product herewith complies with the requirements of the Low Voltage Directive
73/23/EEC and the EMC Directive 89/336/EEC.

Santa Rosa, California, USA 14 July 1995

Dixon Browder/Quality Manager

European Contact: Your local Hewlett-Packard Sales and Service Office or Hewlett-Packard GmbH, Department
ZQ/Standards Europe, Herrenberger Strasse 130, D-71034 Böblingen, Germany (FAX +49-7031-14-3143)

Performance Data for EMC Immunity

Radiated Immunity

When testing at 3 V/m according to IEC 801-3/1984 the displayed average noise level will be within specifications over the full immunity test frequency range of 27 to 500 MHz except that at immunity test frequencies of $278.6 \text{ MHz} \pm$ selected resolution bandwidth and $321.4 \text{ MHz} \pm$ selected resolution bandwidth the displayed average noise level may be up to 45 dBm. When the analyzer tuned frequency is identical to the immunity test signal frequency there may be signals of up to 70 dBm displayed on the screen.

Electrostatic Discharge

When an air discharge of up to 8 kV according to IEC 801-2/1991 occurs to the shells of the BNC connectors on the rear panel of the instrument, spikes may be seen on the CRT display. Discharges to center pins of any of the connectors may cause damage to the associated circuitry.

Instructions for Use

The equipment in this SYSTEM has been designed and tested in accordance with IEC Publication 348, Safety Requirements for Electronic Measuring Apparatus, and has been supplied in a safe condition. The instruction documentation contains information which must be followed by the user to ensure safe operation and to maintain the equipment in a safe condition.

Where to Get Technical Help

Hewlett-Packard Sales and Service Offices

US FIELD OPERATIONS		
<p>Headquarters Hewlett-Packard Company 19320 Pruneridge Avenue Cupertino, CA 95014, USA (800) 752-0900</p> <p>Colorado Hewlett-Packard Co. 24 Inverness Place, East Englewood, CO 80112 (303) 649-5000</p> <p>New Jersey Hewlett-Packard Co. 150 Green Pond Road Rockaway, NJ 07866 (201)627-6400</p>	<p>California, Northern Hewlett-Packard Co. 301 E. Evelyn Mountain View, CA 94041 (415) 694-2000</p> <p>Georgia Hewlett-Packard Co. 2000 South Park Place Atlanta, GA 30339 (404) 955-1500</p> <p>Texas Hewlett-Packard Co. 930 E. Campbell Rd. Richardson, TX 75081 (214) 231-6101</p>	<p>California, Southern Hewlett-Packard Co. 1421 South Manhattan Ave. Fullerton, CA 92631 (714) 999-6700</p> <p>Illinois Hewlett-Packard Co. 5201 Tollview Drive Rolling Meadows, IL 60008 (708) 255-9800</p>
EUROPEAN FIELD OPERATIONS		
<p>Headquarters Hewlett-Packard S.A. 150, Route du Nant-d'Avril 1217 Meyrin 2/Geneva Switzerland (41 22) 780.8111</p> <p>Great Britain Hewlett-Packard Ltd Eskdale Road, Winnersh Triangle Wokingham, Berkshire RF11 5DZ England (44 734) 696622</p>	<p>France Hewlett-Packard France 1 Avenue Du Canada Zone D'Activite De Courtaboeuf F-91947 Les Ulis Cedex France (49 6172) 16-0</p>	<p>Germany Hewlett-Packard GmbH Hewlett-Packard Strasse 6380 Bad Homburg v.d.H Germany (33 1) 69 82 60 60</p>
INTERCON FIELD OPERATIONS		
<p>Headquarters Hewlett-Packard Company 3495 Deer Creek Rd. Palo Alto, California 94304-1316 (415) 857-5027</p> <p>China China Hewlett-Packard Co. 38 Bei San Huan X1 Road Shuang Yu Shu Hai Dian District Beijing, China (86 1) 256-6888</p> <p>Taiwan Hewlett-Packard Taiwan 8th Floor, H-P Building 337 Fu Hsing North Road Taipei, Taiwan (886 2) 712-0404</p>	<p>Australia Hewlett-Packard Australia Ltd. 31-41 Joseph Street Blackburn, Victoria 3130 (61 3) 895-2895</p> <p>Japan Yokogawa-Hewlett-Packard Ltd. 1-27-15 Yabe, Sagami-hara Kanagawa 229, Japan (81 427) 59-1311</p>	<p>Canada Hewlett-Packard (Canada) Ltd. 17500 South Service Road Trans-Canada Highway Kirkland, Quebec H9J 2X8 Canada (514) 697-4232</p> <p>Singapore Hewlett-Packard Singapore (Pte.) Ltd 1150 Depot Road Singapore 0410 (65) 273-7388</p>

Warning Statements Marked on the Product

Warning

RISK OF HIGH LEAKAGE CURRENT:

- **Reliable ground circuit continuity is vital for safe operation of this product**
 - **Never operate with ground conductor disconnected**
 - **Refer to installation manual for additional information**
-

Equipment Ratings

Supply Requirements

Voltage

The nominal line voltage is configured at the factory for either 115 VAC or 230 VAC depending on customer country. The specified range is $\pm 10\%$ of nominal.

Frequency

The nominal line frequencies are 50 and 60 Hz.

Power Ratings

The power consumption of a fully loaded system is 230 VA max.

Environmental Conditions

- For indoor use only.
- Operating temperature 10-40°C (specified temperature 20-30°C)
- Maximum relative humidity 80% for temperatures up to 31°C decreasing linearly to 50% relative humidity at 40°C.
- Operating altitudes 0 to 13,500 m (0 to 45,000 ft). Non-operating to 15,250 m (50,000 ft).

Equipment Installation

Assembly, Location, and Mounting Requirements

The E4900 Option 001 system is delivered fully assembled except for cabling and power connections. Consult the user's manual for the instrument rack for more detail or consult the software user's manual and individual equipment documentation for non-racked pieces of equipment.

Provisions for Lifting and Handling

Consult the user's manual for the instrument rack for instructions on lifting (using provided hooks), anti-tip stabilizers, and limited use of casters.

Protective Earthing Installation

Warning

This is a Safety Class 1 SYSTEM. A protective earth-ground connection is provided by the power cord. The system power shall be supplied by a properly earth-grounded power source. Any interruption of the protective earth-grounding conductor inside or outside of the SYSTEM can make the system hazardous to operators. Intentional interruption is prohibited.

Connection to Supplies

Caution

This SYSTEM is designed for use in Installation Category II and Pollution Degree 2 per IEC 1010 and 664 respectively.

Caution

A fully loaded SYSTEM is configured at the factory for either 115 VAC or 230 VAC, 50/60 Hz operation. Before switching on the system, be sure it is configured for the available line voltage.

Warning

If SYSTEM is to be energized via an external autotransformer for voltage reduction, make sure that its common terminal is connected to a neutral (earthed pole) of the power supply.

Ventilation Requirements

Caution

VENTILATION REQUIREMENT

For E4900 option 001 (racked system), do not obstruct any opening in cabinet paying particular attention to the vents in the top and back. Allow sufficient space so that front and rear access doors can be fully opened at any time. This 60 cm minimum clearance to the front and back allows adequate ventilation. No extra space is required to sides of cabinet.

Consult documentation for individual pieces of equipment not delivered in rack.

Equipment Operation

Explanation of SYSTEM symbols

! inside triangle

The instruction documentation symbol. The product is marked with this symbol when it is necessary for the user to refer to the instruction in the documentation.

CE

The CE mark is a registered trademark of the European Community.

ISM 1-A	This is a symbol of an Industrial Scientific and Medical Group 1 Class A product.
WARNING	Warning denotes a hazard. It calls attention to a procedure which, if not correctly performed or adhered to, could result in injury or loss of life. Do not proceed beyond a warning note until the indicated conditions are fully understood and met.
CAUTION	Caution denotes a hazard. It calls attention to a procedure that, if not correctly performed or adhered to, could result in damage to or destruction of the system. Do not proceed beyond a caution note until the indicated conditions are fully understood and met.
CSA	The CSA mark is a registered trademark of the Canadian Standards Association.
UL	The UL mark is a registered trademark of Underwriters Laboratories, Inc.
ETL	The ETL mark is a registered trademark of ETL Testing Laboratories, Inc., A division of Inchcape Testing Services.

Usage and Protection

Warning

If this system is not used as specified, the protection provided by the equipment could be impaired. This SYSTEM must be used in a normal condition (in which all means for protection are intact) only.

Equipment Maintenance

Transportation

Use original packaging materials for shipment.

Instructions for Cleaning

Clean the exterior of the cabinet using a damp cloth only. See documentation for individual pieces of equipment for their cleaning instructions.

Warranty and License Agreement

Notice

The information contained in this document is subject to change without notice.

Hewlett-Packard makes no warranty of any kind with regard to this material, including but not limited to, the implied warranties of merchantability and fitness for a particular purpose. Hewlett-Packard shall not be liable for errors contained herein or for incidental or consequential damages in connection with the furnishing, performance, or use of this material.

Hewlett-Packard Software Product License Agreement and Limited Warranty

Important

Please carefully read this License Agreement before opening the media envelope or operating the equipment. Rights in the software are offered only on the condition that the Customer agrees to all terms and conditions of the License Agreement. Opening the media envelope or operating the equipment indicates your acceptance of these terms and conditions. If you do not agree to the License Agreement, you may return the unopened package for a full refund.

License Agreement

In return for payment of the applicable fee, Hewlett-Packard grants the Customer a license in the software, until terminated, subject to the following:

Use

- Customer may install the software only on one computer at one time.

- Customer may not reverse assemble or decompile the software.

Copies and Adaptations

- Customer may make copies or adaptations of the software:

- For archival purposes, or

- When copying or adaptation is an essential step in the use of the software with a computer so long as the copies and adaptations are used in no other manner.

- Customer has no other rights to copy unless they acquire an appropriate license to reproduce, which is available from Hewlett-Packard for some software.

- Customer agrees that no warranty, free installation, or free training is provided by Hewlett-Packard for any copies or adaptations made by Customer.

- All copies and adaptations of the software must bear the copyright notices(s) contained in or on the original.

Ownership

- Customer agrees that they do not have any title or ownership of the software, other than ownership of the physical media..

- Customer acknowledges and agrees that the software is copyrighted and protected under the copyright laws

- Customer acknowledges and agrees that the software may have been developed by a third party software supplier named in the copyright notice(s) included with the software, who shall be authorized to hold the Customer responsible for any copyright infringement or violation of this License Agreement.

Transfer of Rights in Software

- Customer may transfer rights in the software to a third party only as part of the transfer of all their rights and only if Customer obtains the prior agreement of the third party to be bound by the terms of this License Agreement.

- Upon such a transfer, Customer agrees that their rights in the software are terminated and that they will either destroy their copies and adaptations or deliver them to the third party.

- Transfer to a U.S. government department or agency or to a prime or lower tier contractor in connection with a U.S. government contract shall be made only upon their prior written agreement to terms required by Hewlett-Packard.

Sublicensing and Distribution	Customer may not sublicense the software or distribute copies or adaptations of the software to the public in physical media or by telecommunication without the prior written consent of Hewlett-Packard.
Termination	Hewlett-Packard may terminate this software license for failure to comply with any of these terms provided Hewlett-Packard has requested Customer to cure the failure and Customer has failed to do so within thirty (30) days of such notice.
Updates and Upgrades	Customer agrees that the software does not include future updates and upgrades which may be available from HP under a separate support agreement.
Export	Customer agrees not to export or re-export the software or any copy or adaptation in violation of the U.S. Export Administration regulations or other applicable regulations.

Limited Warranty

Software Hewlett-Packard warrants for a period of 1 year from the date of purchase that the software product will execute its programming instructions when properly installed on the instrument indicated on this package. Hewlett-Packard does not warrant that the operation of the software will be uninterrupted or error free. In the event that this software product fails to execute its programming instructions during the warranty period, customer's remedy shall be to return the media to Hewlett-Packard for replacement. Should Hewlett-Packard be unable to replace the media within a reasonable amount of time, Customer's alternate remedy shall be a refund of the purchase price upon return of the product and all copies.

Media Hewlett-Packard warrants the media upon which this product is recorded to be free from defects in materials and workmanship under normal use for a period of 1 year from the date of purchase. In the event any media prove to be defective during the warranty period, Customer's remedy shall be to return the media to Hewlett-Packard for replacement. Should Hewlett-Packard be unable to replace the media within a reasonable amount of time, Customer's alternate remedy shall be a refund of the purchase price upon return of the product and all copies.

Notice of Warranty Claim Customer must notify Hewlett-Packard in writing of any warranty claim not later than thirty (30) days after the expiration of the warranty period.

Limitation of Warranty Hewlett-Packard makes no other express warranty, whether written or oral, with respect to this product. Any implied warranty of merchantability or fitness is limited to the 1 year duration of this written warranty. This warranty gives specific legal rights, and Customer may also have other rights which vary from state to state, or province to province.

Exclusive Remedies The remedies provided above are Customer's sole and exclusive remedies. In no event shall Hewlett-Packard be liable for any direct, indirect, special, incidental, or consequential damages (including lost profit) whether based on warranty, contract, tort, or any other legal theory.

Warranty Service

Warranty service may be obtained from the nearest Hewlett-Packard sales office or other location indicated in the owner's manual or service booklet.

Hardware Warranty

Consult the documentation for each piece of hardware to obtain its particular warranty information.

Formatting Conventions Used in this Book

The following icons differentiate those directions and information not applicable to all three E4900 variations.



Applies to directions and information that applies only to the E4900-E4903 system and NOT to its Options 001 or 003.



Applies only to directions and information pertaining to the E4900 Option 001.



Applies only to directions and information pertaining to the E4900 Option 003.



Applies only to directions and information pertaining to the E4900 Option 001 and Option 003.



Applies only to directions and information pertaining to the E4900 and E4900 Option 001.

When these icons appear in a heading, all the information beneath that heading pertains to the specific system variation. When they appear before a paragraph beneath a heading, only the information or directions in that paragraph pertains to the specific system variation.

When no icon appears before a paragraph or its heading, the information and directions pertain to all system variations.

System Overview

This manual describes the installation and operation of your HP E4900 / E4903 (Figure 1-1) including Option 001 (Figure 1-2) and Option 003 (Figure 1-3) High Sensitivity Spectrum Monitoring System (SMS).

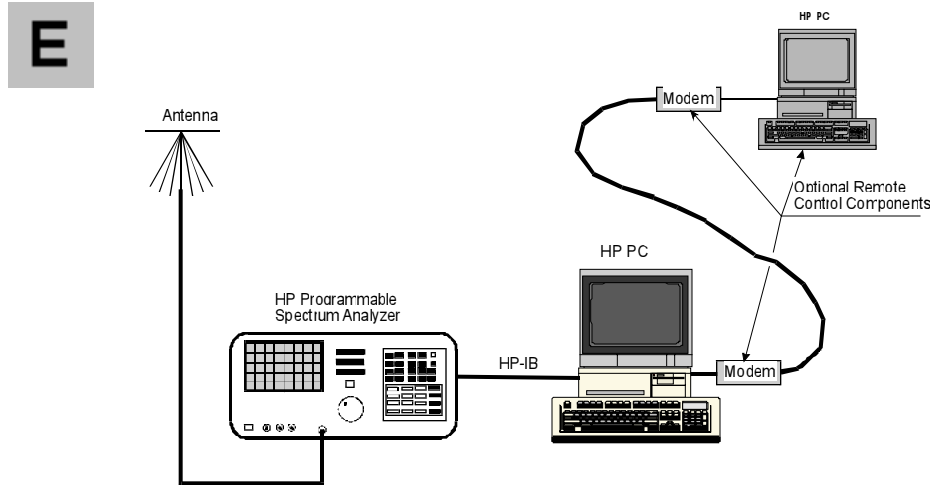

Figure 1-1: Block Diagram of E4900/E4903 Spectrum Monitoring System (Note: Modem not included but available from H-P)

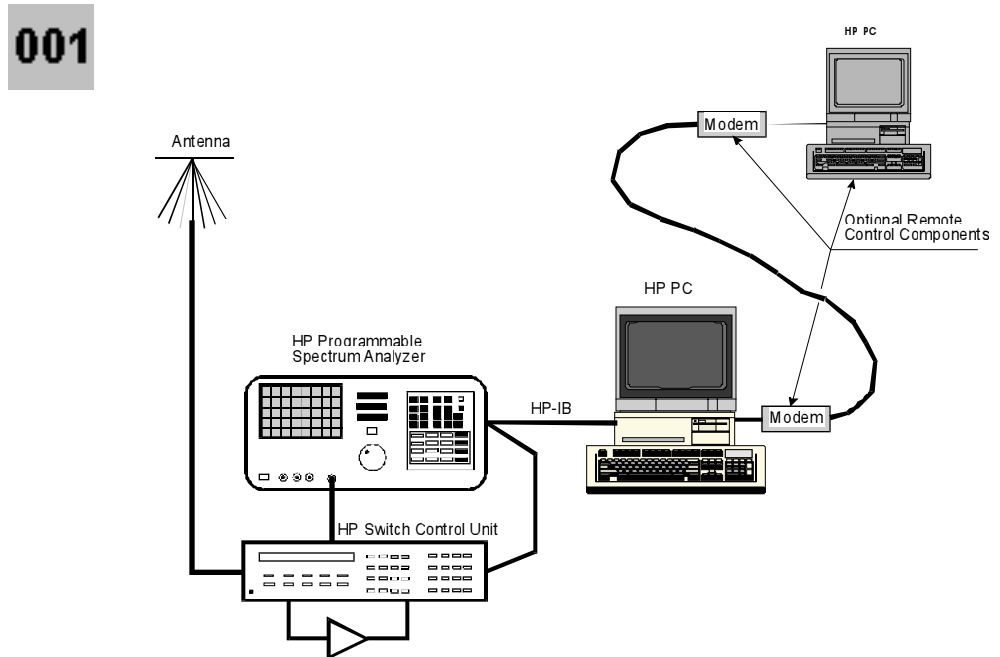

Figure 1-2: Block Diagram of E4900/E4903 Option 001 Spectrum Monitoring System (Note: Modem not included but available from H-P)

003

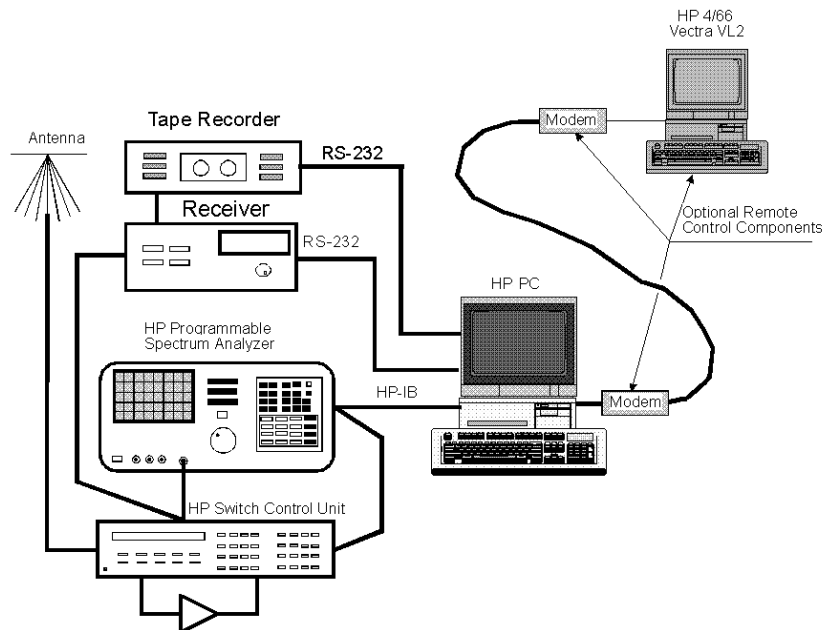

Figure 1-3: Block Diagram of E4900/E4903 Option 003 Spectrum Monitoring System (Note: Modem not included but available from H-P)

Spectrum Monitoring System Overview

The HP E4900 Series Spectrum Monitoring System (SMS) is a high sensitivity spectrum analyzer based system, designed to permit automated and manual monitoring of the electromagnetic spectrum using a Personal Computer running Windows-based Spectrum Monitoring software.

003

A Receiver permits demodulating a selected signal which may be played through a self contained audio speaker and/or recorded by the Tape Recorder.

The system has the capability to monitor frequencies over a frequency range (Spectrum) in accordance with a pre-determined or user defined Monitoring Plan. This is accomplished in the following principle operational modes:

- Wideband, and Band Specific Spectrum Monitoring
- Carrier Specific Monitoring

Wideband Spectrum Monitoring allows you to select frequency bands for monitoring either from a pre-determined frequency monitoring plan or to define your own monitoring plan.

Band Specific Spectrum Monitoring allows you to:

- Make Occupancy Measurements
- Perform Availability Measurements
- Compile Message Length Statistics
- Do Signal Logging (Power and Frequency)

Additionally, you have the ability to define threshold modes for detecting signals, define signal masks to exclude specific signals, define display formats and define conditions for setting alarms.

Carrier Specific Monitoring allows you to select specific signals for monitoring from a pre-defined frequency monitoring plan and to define the sequence in which they are to be monitored as well as to define the following specific Carrier Measurements to be carried out on these signals:

- Center Frequency
- Maximum Power
- Average Power
- Percent AM
- Signal-to-Noise Ratio
- Occupied Bandwidth
- Profile Compliance

The selection of signals to be analyzed is based upon your unique analysis requirements, or is triggered by pre-defined alarm conditions.

In each of the selected modes, the system logs data to a database that can then be used to generate reports using the included report generator or exported to standard Windows based spreadsheet programs such as Microsoft Excel or Quattro Pro.

System Configurations

The primary configuration of your HP E4900 Option 003 SMS is that of a Monitoring Site which provides full functional spectrum monitoring capability. You may configure your Monitoring Site for either Standalone or Remote mode operation.

For Standalone operation, the configuration of your Monitoring Site requires that you will directly attend to the operation of the Monitoring Site.

For Remote operation, your Monitoring Site configuration provides remote control from a Central Site across a serial interface using modems connected by a dial-up telephone line.

Monitoring Site Configuration

The Monitoring Site consists of an Antenna connected to an HP 8591E Programmable Spectrum Analyzer. An HP PC running the Spectrum Monitoring Software controls the spectrum analyzer over the HP-IB.

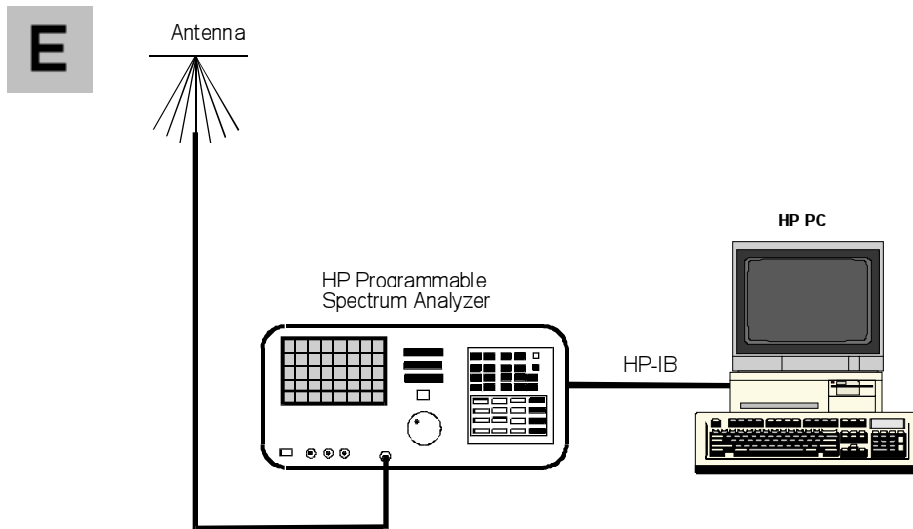

Figure 1-4: Block Diagram of the E4900/4903 Monitoring Site

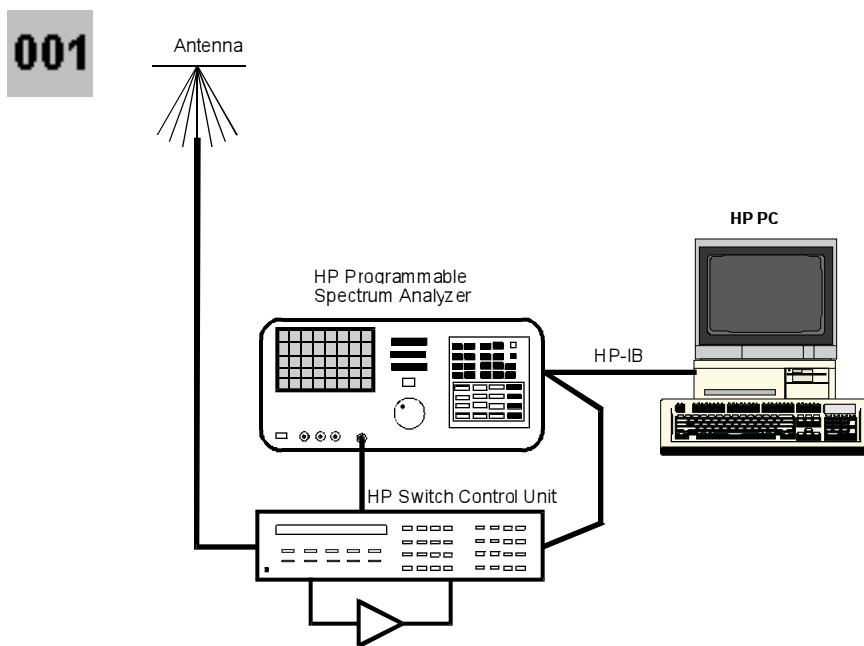

Figure 1-5: Block Diagram of the E4900/4903 Option 001 Monitoring Site



The sensitivity of your system can be adjusted by use of the program-switched broadband preamplifier.

003

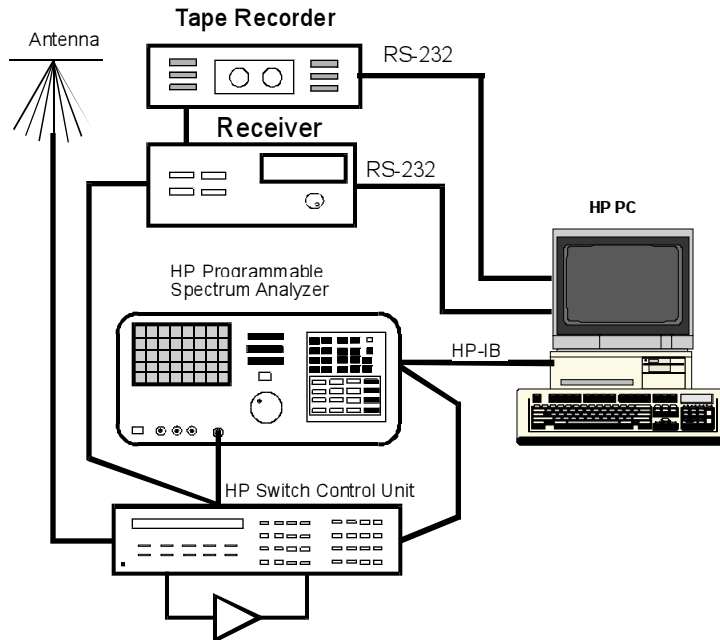

Figure 1-6: Block Diagram of the E4900/4903 Option 003 Monitoring Site

003

The PC-controlled receiver permits demodulating a selected signal which may be played through a self contained audio speaker and/or recorded by the computer controlled tape recorder.

You may operate the system directly or you may set up monitoring plans for automatic unattended operation.

Optional Central Site Configuration

The optional Central Site consists of an HP PC running the Central Site Application Software and provides you with the capability to remotely control the Monitoring Site across a serial interface using modems connected by a dial-up telephone line.

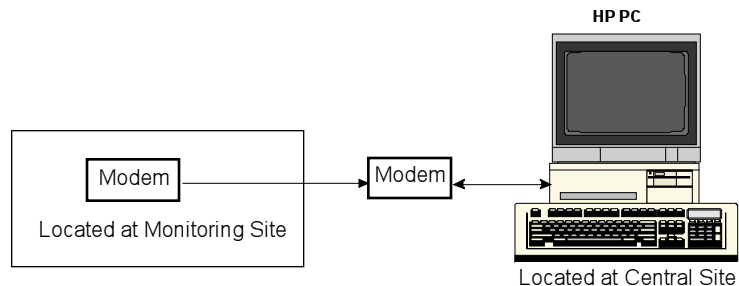

Figure 1-7: Block Diagram of the Central Site

Receiving and Installing Your System

This section provides you with detailed information for receiving and physically installing your HP E4900 Spectrum Monitoring System.



Receiving And Installing Your Monitoring System



Unpacking and Initial Inspection

Inspect the shipping container for damage. If the shipping container shows visible signs of damage, it should be retained until the contents have been checked for completeness and absence of damage. Unpack the SMS Site components and account for each item listed in Detailed Parts List For an E4900 Monitoring Site or the Detailed Parts List for your option of the E4903 Central Site (Table 2-1) as applicable. Visually inspect each component for absence of damage. In the event of damage to any of the components, notify the carrier and HP shipping department. Retain all packing materials and shipping containers for shipper's inspection.

Table 2-1: Detailed Parts List for the E4900

Item	Qty	Vendor	Part Number	Description	Notes
1				Spectrum Analyzer	
1.1	1	HP	8591E	Spectrum Analyzer	
1.1.1	Incl	HP		Spectrum Analyzer Chassis	E
1.1.2	1	HP	Opt. 004	Precision Frequency Ref.	
1.1.3	1	HP	Opt. 021	HP-IB Interface	
1.1.4	1	HP	Opt 908	Rack Mount w/o Handles	
1.2	Incl	HP		AC Power Cord	Cable W5
1.3	Incl	HP		Operation Manual	
2				Control Computer	
2.1	1	HP	D3138B	Vectra VL2 4/66, 340-ABA	
2.1.1	Incl	HP		Computer Chassis	
2.1.2	Incl	HP		HDD, 340 MB Local Bus IDE	
2.1.3	Incl	HP		3.5-in. HD Floppy Drive	
2.1.4	Incl	HP		Memory, 8MB	
2.1.5	Incl	HP		Video RAM, 1MB	
2.1.6	Incl	HP	24541B	Dual Serial Port Board	003

Item	Qty	Vendor	Part Number	Description	Notes
2.2	Incl	HP	C3346-60201	HP Keyboard w/Cable	Cable W12
2.3	Incl	HP	C3751A	HP Mouse M-S34 w/Cable	Cable W13
2.4	Incl	HP		AC Power Cord	Cable W2
2.5	1	HP	82335B	HP-IB Card for Windows & DOS	
2.5.1	Incl	HP	82335-90017	82335B Installation Manual	
2.6	Incl	HP		Vectra Documentation:	
2.6.1	Incl	HP		Setting Up Your PC	
2.6.2	Incl	HP		Using Your PC	
2.6.3	Incl	HP		PC Keyboard Notice	
2.6.4	Incl	HP		User Guide for Windows & DOS	
2.6.5	Incl	HP	E4900-80014	Mouse Pad	
3				Computer Monitor	
3.1	1	HP	D2807A	17-in UVGA Monitor w/ Cable	Cable W11
3.2	Incl	HP		AC Power Cord	Cable W1
3.3	Incl	HP		Documentation:	
3.3.1	Incl	HP		Ultra-VGA User's Guide	
3.3.2	Incl	HP		Set-up & Posture for VTD use	
4				Optional Antenna (Opt 011)	
4.1.1	1	ICOM	AH-7000	Antenna	
4.2	Incl	ICOM		Installation Instructions	
4.3	Incl		E4900-60001	Antenna Cable	 Cable W25
5				HP Vectra Software	
5.1	Incl			MS-DOS 6.2	Pre-loaded
5.2	Incl			Windows for Work Group 3.11	Pre-loaded
5.3	Incl			HP Mouse Driver	Pre-loaded
5.4	Incl			HP User Drivers	Pre-loaded
5.6	Incl		9010-0037	Carbon Copy for Windows	Pre-loaded
6				Software	
6.1	1	HP	E4900-10003	Spectrum Monitoring Software	
6.2	1	HP	E4900-80025	Software Security Module	
6.3	1		9010-0040	CompuServe Manager	

Item	Qty	Vendor	Part Number	Description	Notes
7				Documentation	
7.1	1	HP	E4900-60003	E4900/E4903 Opt 003 User's Guide	
8				HP-IB (IEEE-488) Bus Cables	
8.1	1	HP	10833C	HP-IB Bus Cable, 4-meters	Cable W14
11				Switch/Control Unit Assy.	
11.1	1	HP	3488A	Switch / Control Unit	
11.2	Incl	HP		Operational Manual	
12				Cables Serial Data	003
12.1	1	ATIS	7030293	RS-232 Computer to Recorder	Cable W16
12.2	1	Generic	-	RS-232 Computer to Receiver	Cable W17
14				Preamplifier	
14.1	1	HP	8447D	Preamplifier	
14.2	Incl	HP		Operational Manual	
16				Communications Receiver	003
16.1	1	AOR	5012A28	AR-3000 Receiver	
16.2	1	AOR		AOR AR-3000 Owner's Manual	
17				Voice Tape Recorder	003
17.1	1	ATIS	5012A28	CG-100 Recorder, 1 Channel	
17.2	1	ATIS	09158	Vendor Documentation	
21				HP Cabinet Rack Complete	
21.1	1	HP	E3660A	1.12 meter, 21 EIA unit Cabinet	
21.2	1	HP	Option AW3	120 VAC PDU w/ SW & P-Cord Cable W27	
21.3	1	HP	E4470A	Extractor Fan w/ Power Cord	Cable W10
21.4	1	HP	46298M	Drawer Unit	
21.5	1	HP	40101A	1-EIA filler panel	
21.6	1	HP	40107A	7-EIA filler panel	
21.7	1	HP	E3663A	System II Rail Kit	
21.8	Incl	HP	E3663A	System II Rail Kit	
21.9	Incl	HP		Removable Side Panels	2 Included
21.10	Incl	HP		Vented Rear Door	

Item	Qty	Vendor	Part Number	Description	Notes
21.11	1	HP	40102A	2-EIA filler panel	
21.12	Incl	HP		Vented Top	1 Included
21.13	Incl	HP		19-inch EIA Mounting Columns	4 Included
21.14	Incl	HP		3-inch Casters	4 Included
21.15	Incl	HP		Lifting Hooks	4 Included
21.16	Incl	HP		Base w/ Anti-Tip Foot	
22	Incl		E4900-00007	SA 1-EIA Transition Panel	

Preparation For Use

Power Requirements

Your Monitoring Site requires a standard 3-wire grounded 15-amp branch service supplying Single phase 120 / 220 VAC \pm 10%, 60 Hz primary power. The maximum power consumption of the Monitoring Site is less than 500 Watts.

Warning: For your safety, your Monitoring System hardware components are powered through 3-wire power cords with grounded plugs. **Always** connect each power cord to a properly grounded outlet or power strip to avoid electrical shock.

Operating Environment

Your Monitoring Site requires a free-air environment having a temperature range of between +10 and +40 degrees C, with a relative humidity of between 15% and 80% non-condensing.

Storage Environment

Your Monitoring System should be stored in an environment having a temperature range of between -40 and +70 degrees C, with a relative humidity of between 15% and 80% non-condensing.

E

Work Surface Requirement

Except for the antenna, your Monitoring System is designed to operate assembled on a conventional table or other suitable work surface. The work surface should be capable of safely supporting at least 55 kg (121 lb.), the weight of your monitoring system components, in addition to any other items that you may have on it

001
003

Floor Space and Work Surface Requirement

Except for the optional antenna, your Monitoring System is designed to operate assembled on a conventional table or other suitable work surface and connected to the Monitoring Site Cabinet assembly that houses the Spectrum Analyzer and Switch Control Unit. The work surface for the computer and its peripherals must be capable of safely supporting at least 55 kg (121 pounds), in addition to any other items that you may place on it. Your Monitoring Site Cabinet, which stands 45 inches high, occupies a 2-foot wide by 3-foot deep floor area. The 4-meter interconnect cables linking the Monitoring System with the Monitoring Site Cabinet give you flexibility in arranging your site area.

Installing Your Monitoring System

E

Refer to Figure 2-1 to Figure 2-4 for a functional depiction of the interconnections of your monitoring system while performing the system installation and cabling.

E

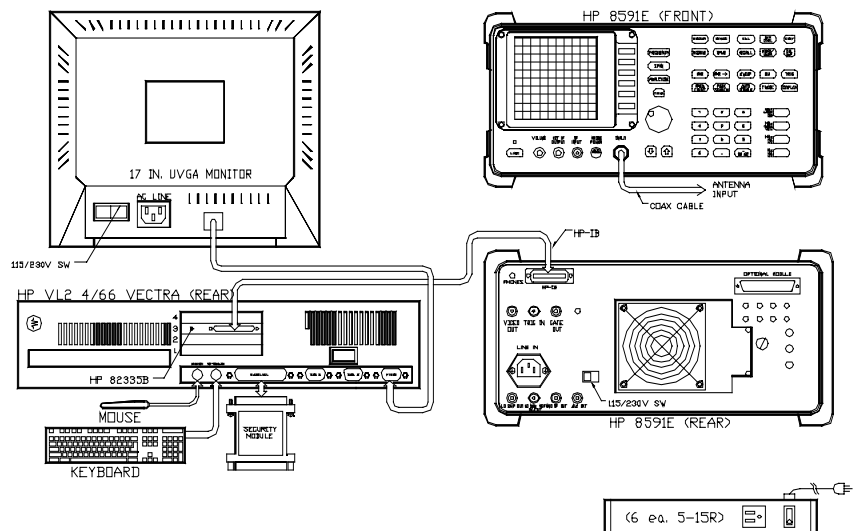

Figure 2-1: : HP E4900 Monitoring Site Assembly Diagram

E

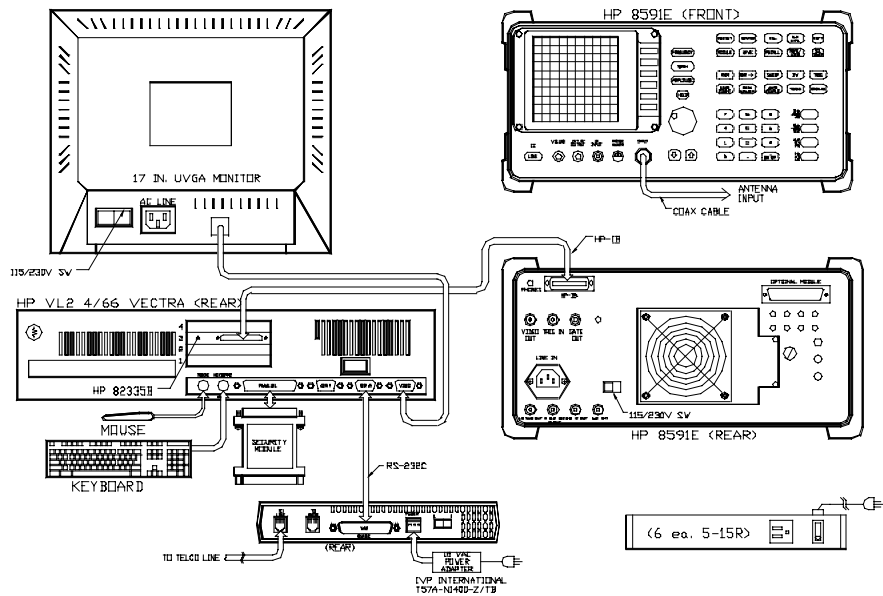

Figure 2-2: HP E4900/E4903 Monitoring Site assembly Diagram

E

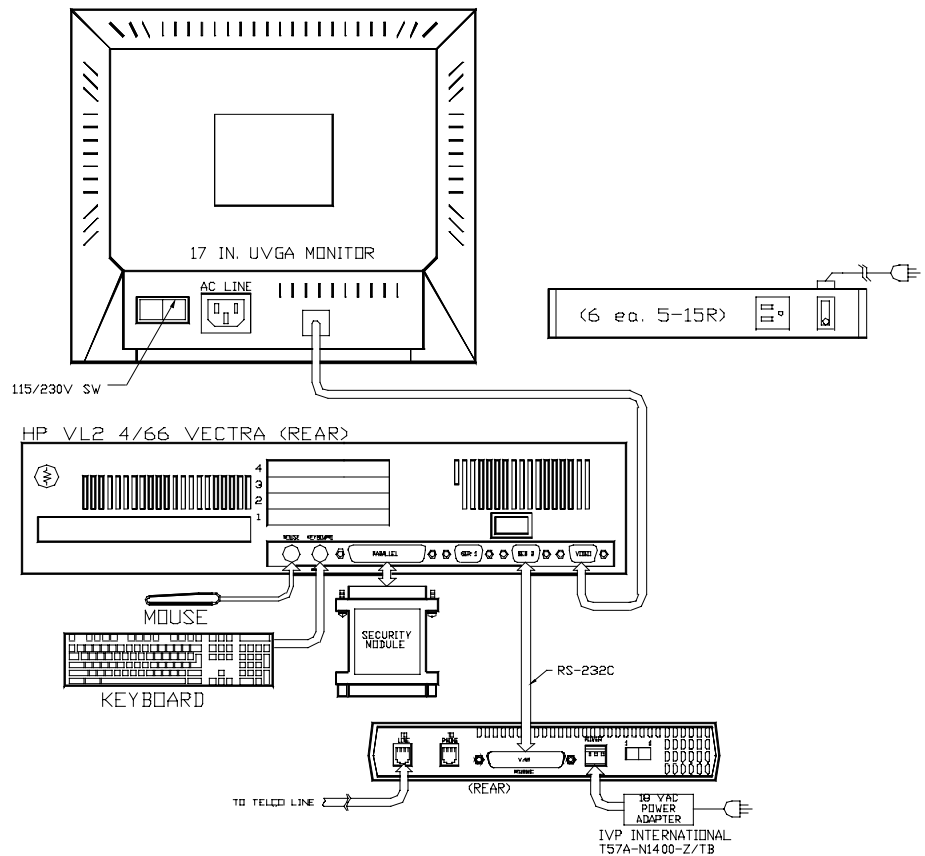

Figure 2-3: HP E4903 Central Site Assembly Diagram

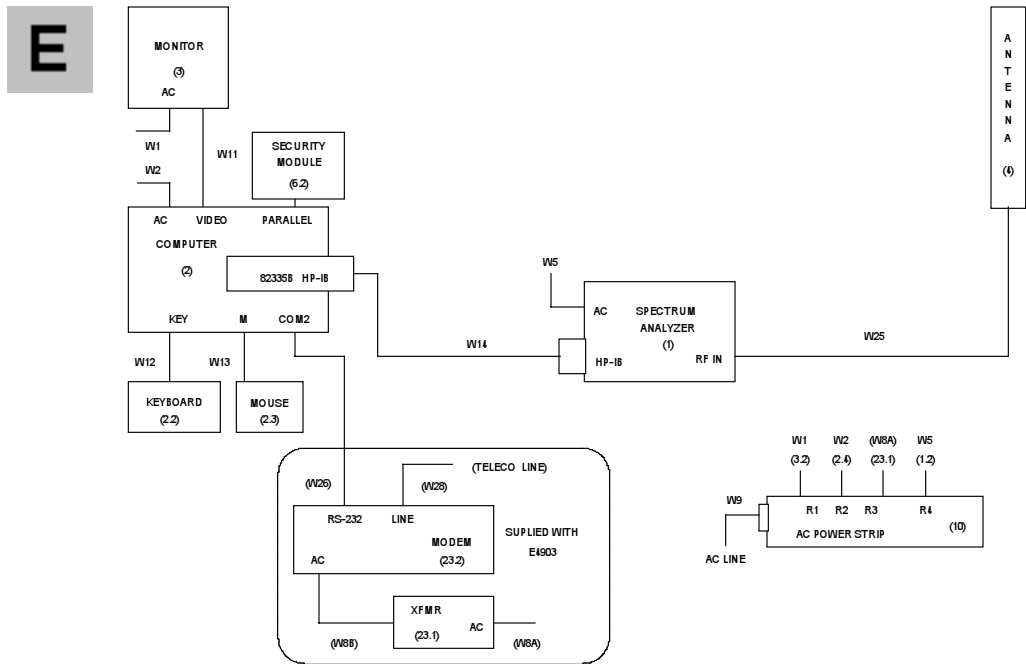

Figure 2-4: : HP E4900 Monitoring Site Interconnect Diagram

001

Refer to Figure 2-5 to Figure 2-7 for a functional depiction of the interconnections of your monitoring system while performing the system installation and cabling.

001

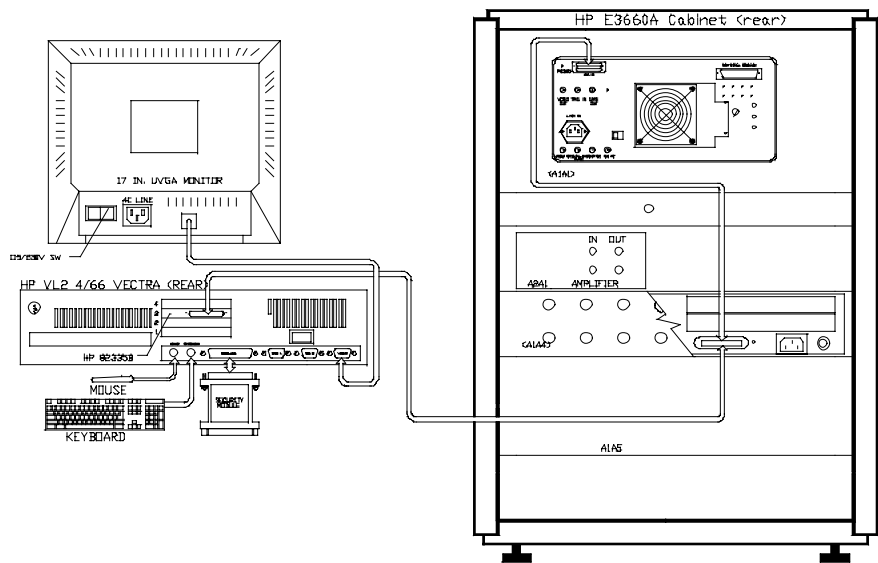

Figure 2-5: : HP E4900 Opt 001 Monitoring Site Assembly

001

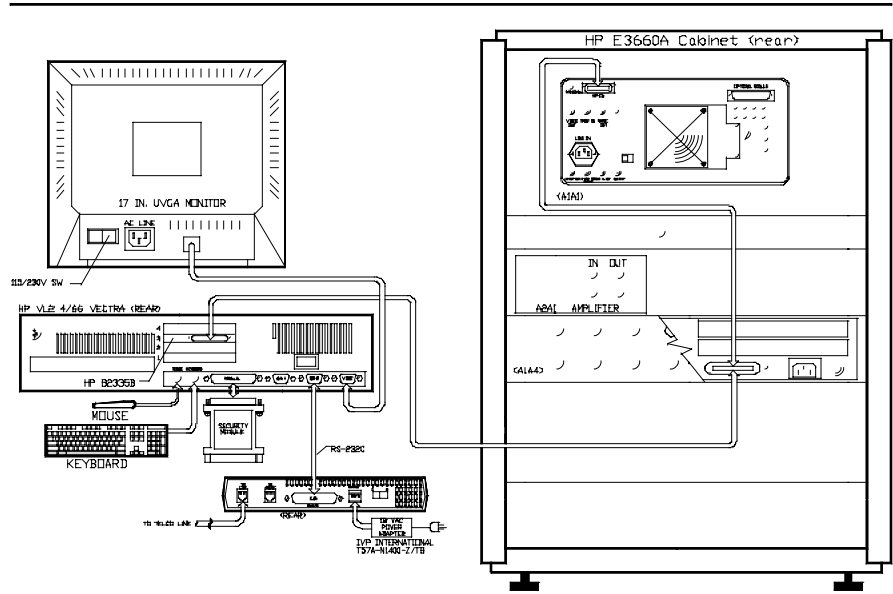

Figure 2-6: :HP E4900/E4903 Opt 001 Monitoring Site Assembly

001

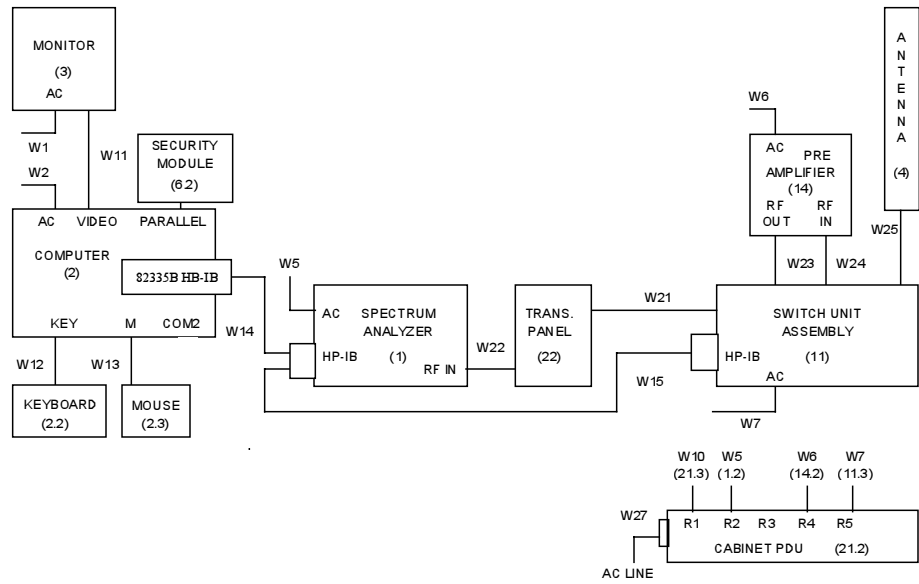

Figure 2-7: :HP E4900 Opt 001 Monitoring Site Interconnect Diagram

003

Refer to Figure 2-8 to Figure 2-10 for a functional depiction of the interconnections of your monitoring system while performing the system installation and cabling. Figure 2-1 HP E4900 Opt 003 Monitoring Site Assembly, Figure 2-2 E4900/E4903 Opt 003 Monitoring Site Assembly are pictorial illustrations to assist you in installing your system.

003

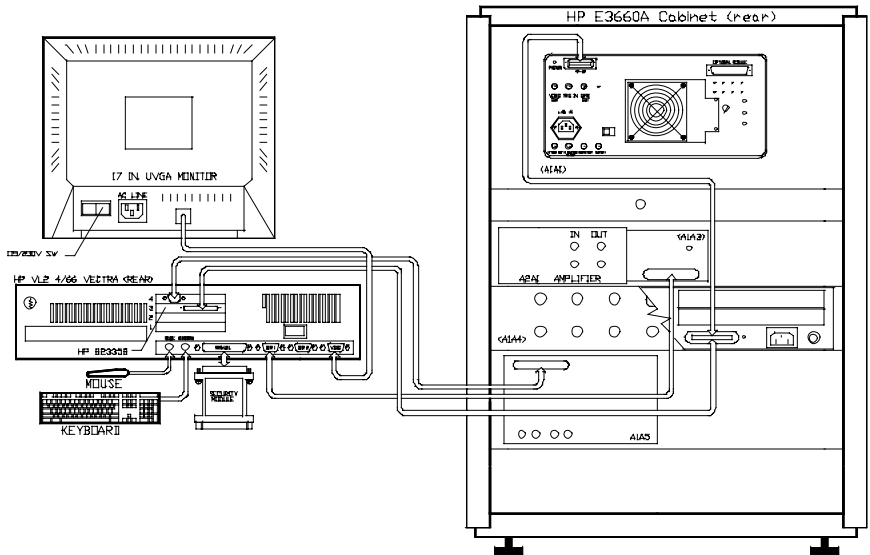

Figure 2-8: : HP E4900 Opt 003 Monitoring Site Assembly

003

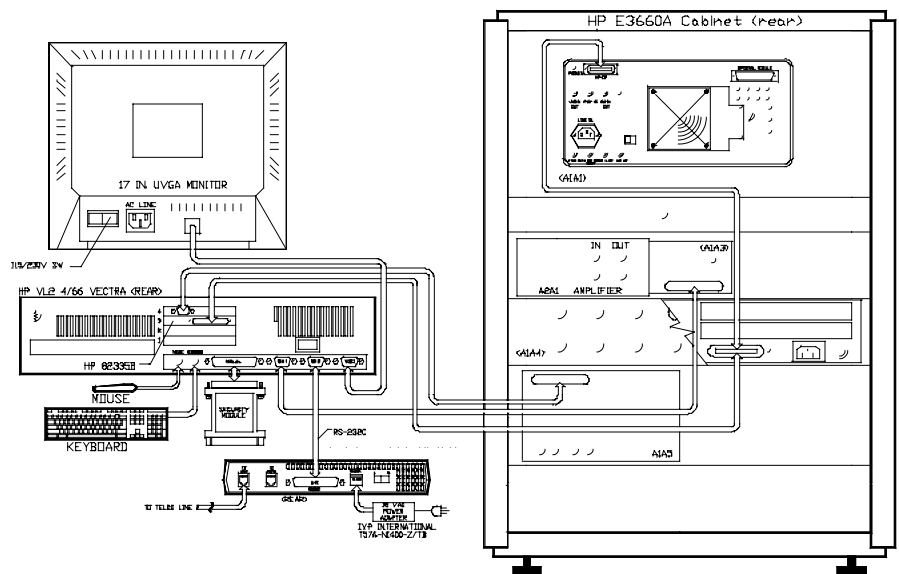

Figure 2-9: HP E4900/E4903 Opt 003 Monitoring Site Assembly

003

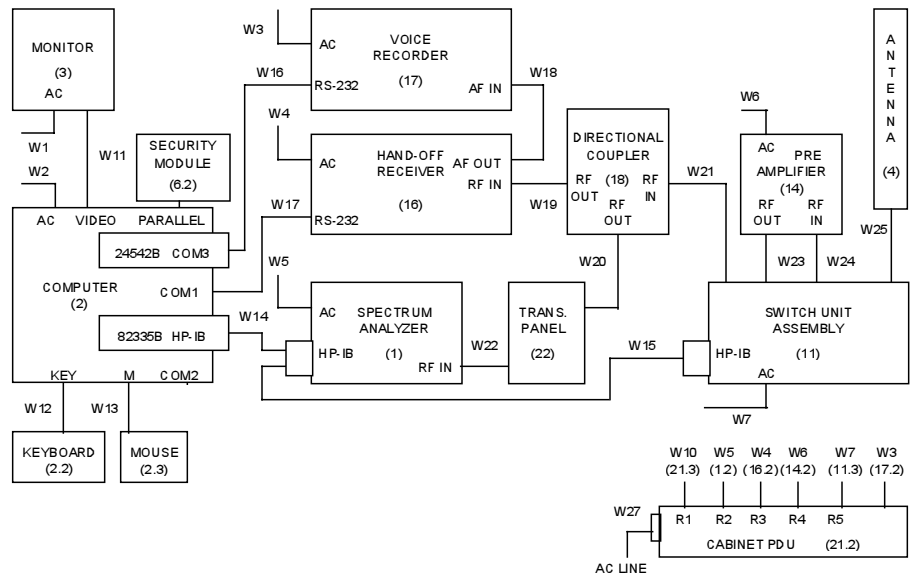

Figure 2-10: : HP E4900 Opt 003 Monitoring Site Interconnect Diagram

Installing The Optional ICOM AH-7000 Antenna

1. Assemble the antenna per the detailed assembly instructions included with the antenna.
2. Connect one end of the 50 foot coaxial feed line (W25) to the antenna and install the antenna on a post or a mast in a convenient indoor or outdoor location.

Warning: *If you are installing the antenna outdoors it is essential that it and supplied coaxial cable do not touch or cross over electrical power lines. Failure to heed this warning may result in serious injury or even death to the installer or the user of the system and may seriously damage your Spectrum Monitoring System.*

Installation Tip

As with any broad band receiving antenna, the normal considerations apply for choosing a mounting location. It should be installed remote from unwanted signals and sources of electrical interference. The distance between the antenna and other antennas, wire fences, metal towers, and the like should be maximized. Generally, the higher the antenna is mounted, the better will be its performance.

E

Installing The HP 8591E Spectrum Analyzer

1. Place the Spectrum Analyzer on the work surface and position it to provide adequate surrounding free space for cabling access and cooling ventilation of the instrument.
2. Connect the free end of the coaxial feed line from the antenna (W25) to the **RF-Input** located on the front panel of the Spectrum Analyzer.

Warning: When routing the coaxial antenna cable make sure that it is placed such that it will not become an obstacle to surrounding foot traffic. Improper cable routing could result in accidental injury to personnel and damage to your monitoring system.

3. Connect one end of the HP-IB bus cable (W14) to the **HP-IB Bus** connector located on the rear panel of the Spectrum Analyzer. The 4-meter HP-IB bus cable connecting the Spectrum Analyzer with the HP PC gives flexibility to the location of the analyzer with respect to the work surface holding the PC.
4. Make sure that the **Line Switch** on the Spectrum Analyzer is in the **OFF** position and that the **Voltage Selector** on the back panel of the Spectrum Analyzer is set to the proper line voltage (i.e. 115V or 220V, 50/60/400 Hz operation).
5. Connect the power cord (W5) between the \sim **Line** input of the Spectrum Analyzer and a properly grounded outlet.

001
003

Installing the Monitoring Site Cabinet Assembly

001

The Monitoring Site Cabinet assembly is totally pre-cabled and includes the Spectrum Analyzer, the Switch Unit Assembly, and the Preamplifier.

003

The Monitoring Site Cabinet assembly is totally pre-cabled and includes the Spectrum Analyzer, the Switch Unit Assembly, the Preamplifier, the ICOM Communications Receiver, and the ATIS CG-100 Voice Tape Recorder.

To install the Monitoring Site Cabinet Assembly:

1. Position the Monitoring Site Cabinet Assembly with respect to the table work space allocated for the HP Vectra series PC and peripherals to permit their interconnection with the 4 M (12 ft) HP-IB cable (W14).
2. Make sure that the main **Power Switch** on the Monitoring Site Cabinet assembly is in the **Off** position.
3. Verify that the **Voltage Selector** switches on the Spectrum Analyzer, and the Preamplifier are set to the proper line voltage (i.e. 115V or 220V 50/60/400 Hz operation).

4. Connect the free end of the coaxial feed line from the antenna (W25) to the RF input of the Switch Unit Assembly.
5. Connect one end of the HP-IB bus cable (W14) to the **HP-IB Bus** connector, located on the rear panel of the Spectrum Analyzer in the Monitoring Site Cabinet Assembly.

***Note:** There already is an HP-IB cable W15 connected to the Spectrum Analyzer which links it to the Switch Unit Assembly. Plug the new HP-IB bus cable into the connector of this cable.*

6. **003** Connect one end of the RS-232 Control Cable W16 to the RS-232 port of the Voice Recorder.
7. **003** Connect one end of the RS-232 control Cable W17 to the RS-232 port of the Hand-off Receiver.
8. Connect the power cord (W5) between the \sim **Line** input of the Spectrum Analyzer and a properly grounded outlet.

Installing The Hewlett-Packard PC

1. Place the HP PC, the Monitor, Keyboard and Mouse on the work surface and arrange them in a comfortable working layout.
 Place it within the 4-meter cabling distance from the Monitoring Site Cabinet Assembly
2. Verify that the keyboard cable (W12) has been pressed into the keyboard's cable retainer slot on the underside of the keyboard and connect the free cable end to the **Keyboard** connector located at the rear of the PC, which is identified with the Keyboard Icon.

***Note:** The purpose of the cable retainer slot is to minimize strain on the cable at the point of attachment to the keyboard.*

3. Connect the free end of the mouse cable (W13) to the **Mouse** connector, identified with the Mouse Icon and located on the back of the PC.
4. Connect the monitor cable (W11) between the Monitor and the **Monitor** connector, identified with the Monitor Icon located on the back of the PC.
5. Connect the Software Security Module to the **Parallel Port**, identified with the Parallel Icon located on the back of the PC.
6. Connect the free end of the HP-IB bus cable (W1) to the **HP-IB Interface Board** located in the #2 Accessory Board Slot accessible from the back of the PC.

7. If configured for **Option E4903**, connect one end of the DB-9 shell connector of the serial cable (W26) to the **Serial Port (COM2)**, identified with the Serial Icon and located on the back of the PC.

***Note:** The COM2 Serial Port is the second serial port to the right of the Parallel Port to which the Security Module is connected.*

003

8.
 - a. Connect the free end of the RS-232 Control Cable W16 connected to the Voice Recorder to the **Serial Port (COM 3)**.
 - b. Connect the free end of the RS-232 Control Cable W17 connected to the Hand-off Receiver to the **Serial Port (COM 1)**.
9. Verify that all cable attachment screws are securely tightened.
10. Make sure that the Power switches on the Monitor and the PC are in the **Off** position.
11. Connect the AC power cords (W1) to the Monitor and (W2) to the PC, to a properly grounded outlet.

Review all the installation steps, and if found to be complete, proceed to **Chapter 3: Activating Your System**.

Activating Your System

This section describes the procedures for powering up your Monitoring System, performing a confidence test on your system to establish proper operation, and performing a proper system shutdown.

Power Up

001

Prior to power up, make sure that the power switches on the Spectrum Analyzer, the Preamplifier, and the Switch Unit mounted in the Monitoring Site Cabinet Assembly are set to the **On** position.

003

Prior to power up, make sure that the power switches on the Spectrum Analyzer, the Preamplifier, the Switch Unit, Voice Recorder and the Hand-Off Receiver mounted in the Monitoring Site Cabinet Assembly are set to the **On** position.

To power up your system, turn on the power switches in the following order:

1. **E** Spectrum Analyzer
2.  Main power switch on the Monitoring Site
3. Display Monitor
4. HP PC
5. The Modem, if applicable.

Your system will now power up and the Monitoring Software will execute to display the HP E4900 control window (Figure 3-1).

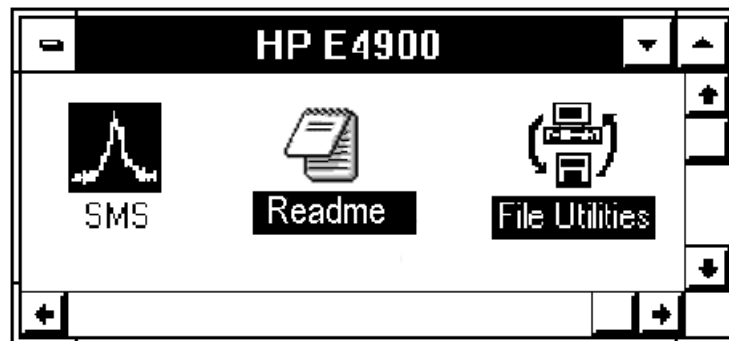

Figure 3-1: : HP E4900 Control Window

Starting Your Monitoring Site

Your SMS Monitoring Site Computer is pre-loaded with the appropriate Spectrum Monitoring Application Software for your Monitoring Site.

Your Monitoring Site may be operated as either **Standalone** or **Remote**.

- As **Standalone**, your Monitoring System requires you to directly attend to the operation of the monitoring site by performing all the functions from the system keyboard and the mouse.
- As **Remote**, using the Carbon Copy software, you to control your Monitoring System from a Central Site over a serial interface, using modems connected by a dial up telephone line.

Starting Your Monitoring System

Your E4900 SMS has been configured by the factory to begin when the HP PC is powered up. If you wish to remove this feature:

1. In Windows Program Manager, double click on the Startup group icon.
2. Select (click on) the SMS Launcher Icon.
3. Press the Delete key and confirm that you wish to remove this icon.

To start your monitoring system:

1. Double click the **SMS** icon (Figure 3-1) in the HP E4900 Control Window.

Your system will now activate all the required software components, and briefly display the **Copyright Logo** similar to Figure 3-2.

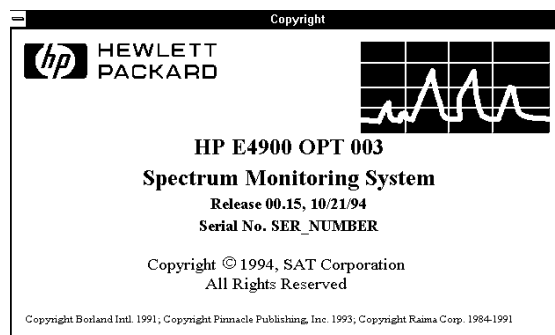

Figure 3-2: : HP E4900 Copyright Logo

2. After a few moments, the Copyright Logo will be replaced with the HP E4900 Series Spectrum Monitoring System Menu and Status Bar similar to Figure 3-3.

HP E4900 Series Spectrum Monitoring System (Opt 003)					
File	Setup	Reports	View	Control	Help
				RF SW: ACTIVE	SCHED: IDLE
OCC: IDLE	CAR: IDLE	SLP: IDLE	STAT: IDLE	MSK: OFF	MONITORING: IDLE

Figure 3-3: : HP E4900 Spectrum Monitoring System Menu and Status Bar

The display of the Monitoring System Menu and Status Bars indicates that your software is operating properly. To establish that all the other components of your system are performing as required, you should perform a simple System Verification Test.

System Verification Test

The System Verification Test demonstrates that all the other system components beside the PC and system software are operational, properly configured, and connected.

To perform the test:

1. Click **Control** on the Menu Bar and then select **Spectrum Analyzer** from the dropdown control menu.

The Spectrum Analyzer Window (Figure 3-4) will come up displaying a default sweep covering the frequency range of the Spectrum Analyzer or the last frequency band monitored as applicable.

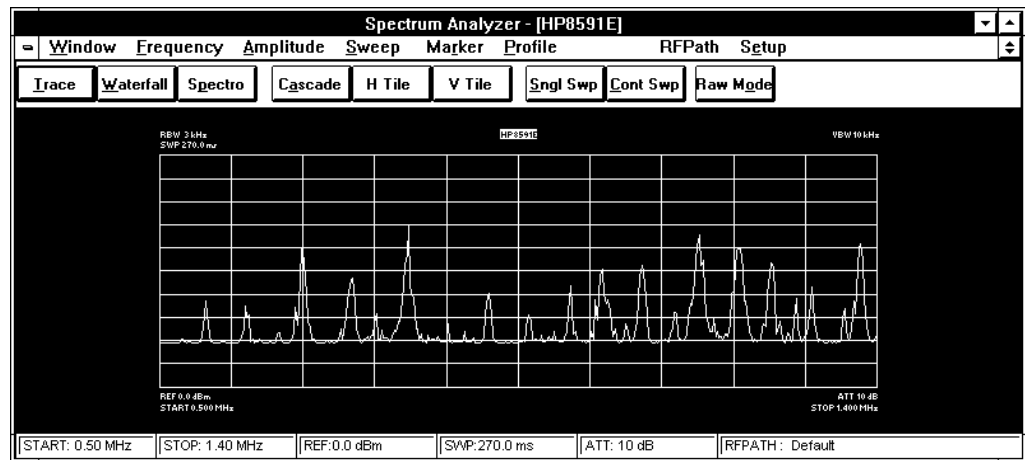

Figure 3-4: : Typical Spectrum Analyzer Window Display

2. Verify that your system is detecting and displaying signals in the opened band.

At this point your Monitoring System has been successfully started and you may begin to use your Monitoring System as described in Chapters 4 through 11.

Terminating And Shutting Down Your Monitoring System

Shutting-Down

To shut down your monitoring system:

1. Click on **File** on the menu bar as appropriate and select **EXIT** from the dropdown menu.
2. Your monitoring application will terminate and you will be returned to the Windows **Program Manager** window.
3. Click **File** and select **Exit Windows** from the drop down menu to close the Windows application and return your system to the MS DOS C:> prompt.

Your Spectrum Monitoring Application Software and your Windows application software are now properly terminated.

Turn OFF the AC power to on all system components to complete the shut down of your Site.



Introducing Your Monitoring System

In chapters 4 through 11, you will learn how to use your HP E4900 Spectrum Monitoring System to perform the following four basic types of tasks:

- **Signal Logging** of Carrier Amplitude and Frequency
- **Carrier Measurements** such as Average Power, Signal-To-Noise Ratio and Occupied Bandwidth.
- **Occupancy Measurements** such as Percentage Occupancy and Message Length Statistics.
- **Statistical Measurements** including Maximum Channel Power and Average Channel Power

You can totally automate the above tasks by including them in your own **Monitoring Plans** to operate on specific frequencies or bands of frequencies as described in Chapter 6. You may then execute your Monitoring Plans directly or under the control of the built-in **Scheduler** as describe in Chapter 7. When done, use the **Report Generator** to display or print Graphics or Text Reports of your data as described in Chapter 8. All of this can be done remotely if you are using the HP E4903 Central Site System as described in Chapter 11.

To further enhance your monitoring capability, your monitoring system offers you customizing features to:

-  Optimize the RF signal path for your monitoring application
- Set up signal masks that exclude undesirable signals from being logged
- Establish alarm criteria to set and log alarms when these criteria are met
-  In addition to logging the alarm parameters, you may program your system to automatically handoff to a receiver and a tape recorder for aural monitoring and recording of alarm events.

Signal Logging with the HP E4900

Signal logging is a wideband monitoring task where you specify a frequency band to detect and log transmissions that occur above a specified threshold. The detected signals and complete trace displays may be logged to a database to be reviewed and analyzed later by displaying Reports and using the Multiple Band Display Window. Additionally you may establish alarm criteria that will cause only the signals meeting these criteria to be logged to the database.

-  Additionally you may establish alarm criteria that will cause only the signals meeting these criteria to activate a receiver and tape recorder hand-off.

Carrier Measurements with the HP E4900

Carrier Measurements is a narrowband monitoring task that is performed on a specific frequency, not bands of frequencies, to determine and log the characteristics of that signal. Carrier measurements may be performed automatically under a pre-defined Monitoring Plan or manually while operating the spectrum analyzer directly. A carrier measurement determines the following signal characteristics:

- Center Frequency of Signal
- Maximum Signal Power
- Average Signal Power
- Signal to Noise Ratio
- Occupied Bandwidth of the Signal
- % Amplitude Modulation
- Compliance to a user defined signal profile.

You may define signal characteristic criteria that, when exceeded, will set and log alarms to a database, and/or activate receiver and tape recorder handoff.

003

You may define signal characteristic criteria that, when exceeded, will activate a receiver and tape recorder handoff.

Occupancy Measurements with the HP E4900

Occupancy Measurements is a wideband monitoring task. You define a band that covers a number of discrete channels and then collect channel use (Occupancy) and message length data for that band. You may collect data either over a single period of time to determine **Running Occupancy** or over a series of contiguous user specified time intervals to determine **Interval Occupancy**. The data gathered during occupancy measurement is logged to a database and is available in the form of graphic reports for **Running Occupancy** and as text reports in the case of **Interval Occupancy**. You may additionally set up alarm conditions that, when met, will set and log the alarm condition to the database.

003

You may additionally set up alarm conditions that, when met, will set and log the alarm condition to a activate receiver and tape recorder hand-off.

Statistical Measurements with the HP E4900

Statistical Measurements is a wide band monitoring task. You define a band that covers a number of discrete channels to determine Channel Maximum and Average Power statistics and Channel

Availability for each channel. The statistical data is acquired over 5 minute time intervals during the overall monitoring time period. The data acquired can then be presented graphically by using the HP E4900 report generator or exported to a spreadsheet program such as Microsoft Excel to view it in text format or produce custom graphs.

***Note:** The 5 minute time interval is the factory default setting. See **Chapter 12: System Administration** for instructions on how to change the default setting.*

System Capabilities

Your Monitoring System is centered around the HP 8591E Spectrum Analyzer which, together with the specialized Monitoring System software offers you a wide variety of advanced signal monitoring capabilities. Starting with direct control of the Spectrum Analyzer, the system also provides fully automatic scheduled execution of custom tailored Monitoring Plans. A variety of features is incorporated that enhances your ability to perform your monitoring tasks more completely and efficiently.

Spectrum Analyzer Window

The Spectrum Analyzer Window is a fundamental mode of your Monitoring System that provides you with direct control of selected functions of the Spectrum Analyzer. This mode offers you the capability to:

- Rapidly set up the analyzer to monitor a signal or a frequency band
- Perform carrier measurements
- Modify monitoring parameters and immediately see the result

The Spectrum Analyzer Window provides you with quick and easy visibility of signals in your frequency bands of interest.

Full Spectrum Analyzer Control

The Spectrum Analyzer Window includes full Spectrum Analyzer control to let you:

- Set up Start/Stop or Center Frequency and Span
- Set the Reference Level, Attenuation, and the Detection Threshold and Sweep Rate to define a monitoring band

You may name this band and store it for recall and execution at a later time.

Measurement Features Of the Spectrum Analyzer Window

To perform monitoring you may operate on the newly created monitoring band or recall a previously defined and stored band. While monitoring is in progress, you may change the monitoring parameters to optimize your monitoring scenario. While viewing a selected band you may elect to perform a Carrier Measurement at a specific frequency by placing a Marker on the signal of interest. Additional Spectrum Analyzer Window capabilities allow you to set a Detection Threshold and to define a Monitoring Profile for checking signal compliance.

003

In the cases where you would like to listen to the signal, you can select it with a Marker and the Handoff Receiver will be tuned to that frequency.

Display Features Of the Spectrum Analyzer Window

When viewing the Spectrum Analyzer Window you have a choice of display formats. Spectrum Analyzer Window, by default, comes up in the **Trace** display mode which displays detected power versus frequency. In addition, you can view Power -versus Frequency versus Time in either a Waterfall Display or a Spectrogram Display. The **Waterfall** display presents 5, 8 or 12 of the most recent traces. The **Spectrogram** display presents a frequency, power, time line plot depicting power in 4 distinct color coded power levels.

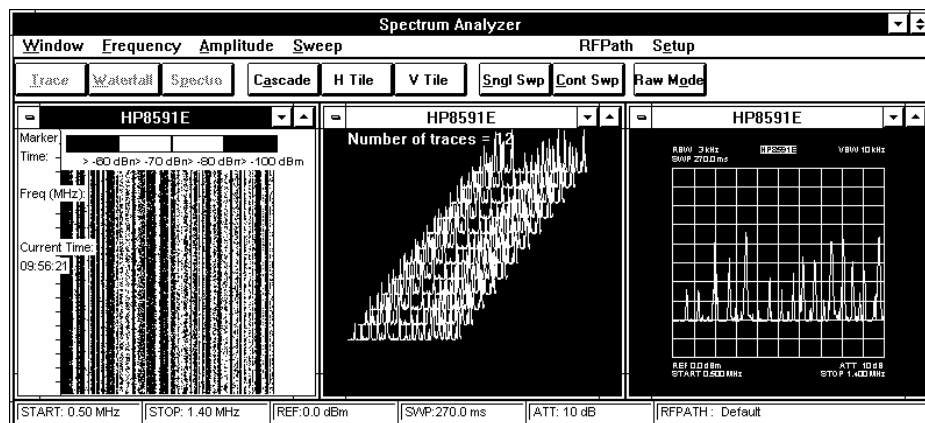

Figure 4-1: Typical Spectrum Analyzer Display

Multiple Band Window

The **Multiple Band Window** lets you view up to 8 different bands at the same time. The bands, which are updated sequentially, can be displayed in any of the three display modes. (Trace View, Waterfall or Spectrogram).

003

In addition, you can hand-off any signal to the Receiver using the Marker Mode of operation.

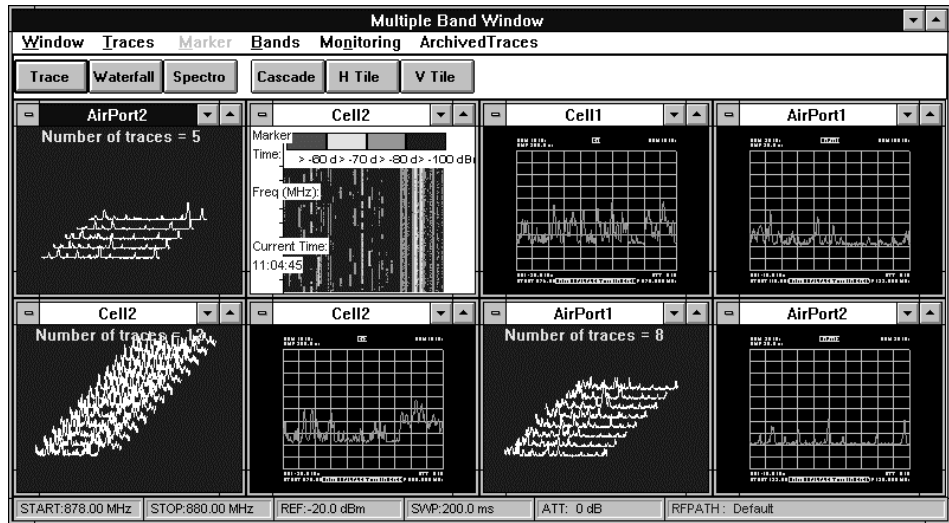

Figure 4-2: Multiple Band Window Displaying 4 Bands

Automatic Monitoring

All of the basic monitoring tasks may be performed automatically by executing a pre-programmed Monitoring Plan directly or in accordance with a schedule that you may establish for your particular monitoring need. Your system offers a number of customizing features that enhances your monitoring effectiveness by permitting you to mask out undesirable signals, set automatic alarm conditions, and define monitoring profiles and automatically switch in a Receiver and a Tape Recorder to let you listen to and record specially designated transmissions.

003

You can automatically switch in a Receiver and a Tape Recorder to let you listen to and record specially designated transmissions.

Monitoring Plans

Monitoring Plans define the monitoring task to be performed by linking a frequency band or bands with any one of the four possible measurement task types. Your system includes a number of pre-defined sample Monitoring Plans, ready to execute. Also, you can create your own custom Monitoring Plans. Once created, a Monitoring Plan may be saved under a unique name for later use.

Scheduled Monitoring

You may schedule your system to perform monitoring automatically to start and stop on a specific date and time without manual intervention. To schedule your system you make use of the built in **Scheduler** to assign start and stop dates and times to previously created Monitoring Plans.

Report Generation

The execution of each Monitoring Plan results in corresponding monitoring data, logged to a database. You may review and print Graphics or Text Reports of your data by using the **Report Generator** or you can export the data to a spreadsheet program such as Microsoft Excel to view in text format or to create custom graphs.



Automatic Switching Between Antennas

If you have purchased this feature, your Monitoring System includes the capability to automatically switch between antennas, that are matched to the band, when that band is monitored. (This is a custom option and not part of the standard product.) In addition, each available antenna is incorporated in an RF Path that includes the capability to switch in a preamplifier as required (Figure 4-3).

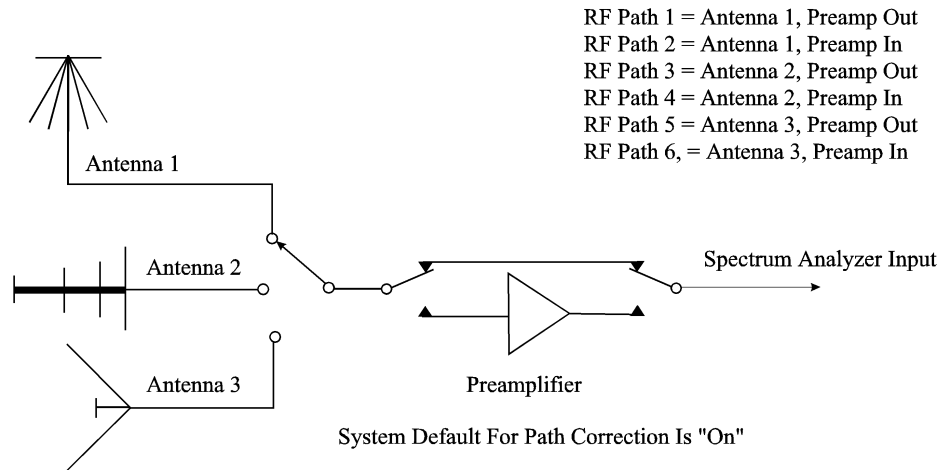

Figure 4-3: Illustration of Antenna Switch Path Concept.

This feature is a custom option and not part of a standard E4900 SMS system.

Path Correction

The system software includes tables of path correction values for each of the possible path selections. Path correction is activated by default when the system is shipped. This means that all computer displayed traces and values will be corrected for the path selected. Note that, in the Spectrum Analyzer Window, it is possible for the user to turn Path Correction on and off to see its effect. This does not change the default settings of the Spectrum Analyzer Window.

To minimize the risk of collecting erroneous data, the settings for Path Correction can only be changed by System Administrative action as described in Chapter 12.

Remote Site Operation

Your Monitoring System may be used as a Remote Site Monitoring System able to be controlled from a Central Site using the included Carbon Copy software (Chapter 11). This configuration permits you to remotely command the Monitoring System to perform the same monitoring functions that you would normally command from its keyboard if you were in direct attendance.

When viewing the display at the Central Site, you may perceive that some screen updates take slightly longer because all communications with the Remote Site is now over a serial communications line.

The most effective use of your Remote Site Monitoring System will occur when you use your Central Site System to pre-program the Remote Site with Monitoring Plans that are then automatically executed under a scheduled monitoring (See **Chapters 6: Monitoring Under a Plan**, and **Chapter 7: Running and Controlling Your Monitoring Plan**). To most efficiently use the serial communications link between the Remote and Central Site, periodically interrogate the Remote Monitoring System to transfer only reduced data back to your Central Site.

Operating Your System

You may operate your system in any one of the following major operating categories:

- As a standalone manually controlled Spectrum Analyzer
- To automatically execute a pre-defined Monitoring Plan
- To execute a Monitoring Plan to a specific schedule
- To generate reports
- To operate as a Remote Site controlled by the Optional Central Site

All major system operations are performed from the HP E4900 Series Monitoring System Menu Bar (Figure 5-1). It is from here that you perform system parameter setup, execute monitoring functions, set up display modes, and invoke control of the various system components and parameters. Just under the Menu Bar is the Monitoring System Status Bar, similar to Figure 5-1 below, which continually displays system configuration and monitoring status.

HP E4900 Series Spectrum Monitoring System (Opt 003)								
File	Setup	Reports	View	Control				Help
						RF SW: INACTIVE	SCHED: IDLE	
OCC: IDLE	CAR: IDLE	SLP: IDLE	STAT: IDLE	MSK: OFF	MONITORING: IDLE			

Figure 5-1: HP E4900 Series Monitoring System Menu Bar

Operating The Spectrum Analyzer Window

The Spectrum Analyzer Window provides you with the ability to control the Spectrum Analyzer directly for rapid analysis of a signal or a signal band. This mode of operation permits you to quickly change monitoring parameters and immediately see the resulting effect.

Opening the Spectrum Analyzer Window

To open the Spectrum Analyzer Window:

1. Click on **Control** on the main **Menu Bar**.
2. From the dropdown Control Menu, select **Spectrum Analyzer**.

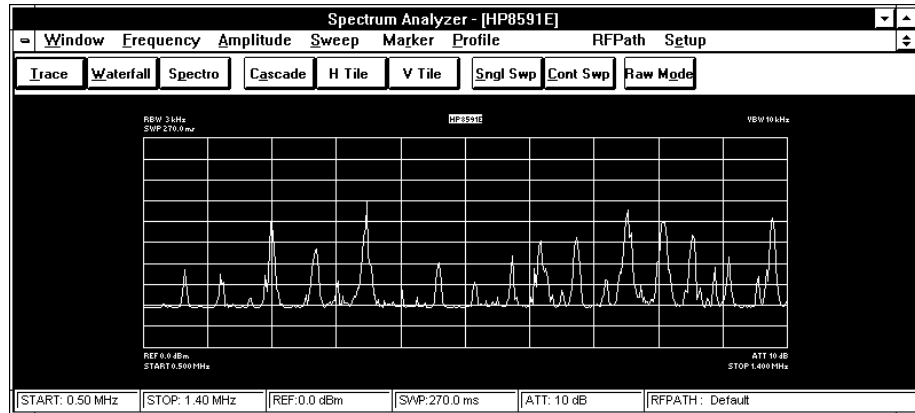

Figure 5-2: Spectrum Analyzer Window Displaying Trace View

The Spectrum Analyzer Window (see Figure 5-2) comes up displaying a static single trace of the last band monitored.

3. To start active monitoring, click on **Cont Swp** in the **Spectrum Analyzer Button Bar**.

In the Spectrum Analyzer Window you may easily change the following monitoring parameters and monitoring functions for immediate evaluation of effect:

- Set or modify band monitoring Start and Stop Frequencies
- Set or modify Resolution and Video Bandwidth
- Set or modify Amplitude parameters such as Reference Level, Attenuation and Threshold
- Set Spectrum Analyzer Sweep Time
- Define monitoring profiles
- Select RF Path and apply Path Gain Correction
- Perform manual measurements using Marker
- Perform Carrier Measurements and **003** Receiver Handoff
- Save monitoring settings as Band Definitions for later use
- Recall previously saved Band Definitions for review or modification
- Insert specific command settings to the Spectrum Analyzer, (Such as "IP;" to preset the analyzer), using the RAW Mode and entering the appropriate command string

To enhance your ability to evaluate monitoring the selected band visually, you have the option to select an additional two display formats of **Waterfall** and **Spectrogram** to complement the

default Trace display format. You may display them simultaneously by clicking either on **Horizontal Tile** or **Vertical Tile** on the **Spectrum Analyzer Button Bar**.

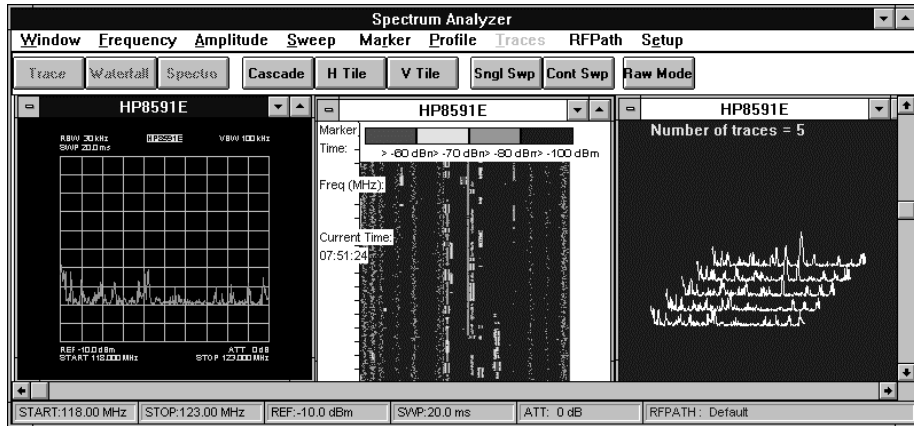

Figure 5-3: Simultaneous Trace, Spectro and Waterfall Displays

***Note:** Simultaneous display in either the Horizontal or Vertical tile format distorts the aspect of the individual display windows. For the most accurate measurements using the Marker, it is recommended that you maximize a single Trace display window.*

Setting and Modifying Monitoring Band Frequencies

You have two options on how you may set or modify the frequencies for the band that you wish to monitor. You may:

- Set the Start and Stop Frequencies for a Band
- Set the Center Frequency and Span for a Band

Setting the Start and Stop Frequencies for a Band

1. Click on **Frequency** on the **Spectrum Analyzer Menu Bar** and from the dropdown menu select **Start Frequency** to open the **Frequency Input** dialog box (Figure 5-4).

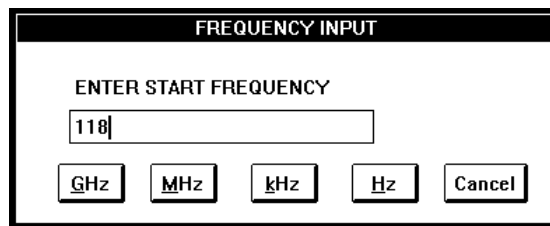

Figure 5-4: Typical Frequency Input Dialog Box

2. Enter the desired start frequency and then click on the appropriate frequency units for the required change to take effect.
3. Repeat the above steps to set the **Stop Frequency**.

***Note:** The Frequency Input Dialog boxes are identical for each of the frequency parameters except for the title which reflects the frequency parameter entered.*

Setting the Center Frequency and Frequency Span for a Band

To define a monitoring band by setting the Center Frequency and Frequency Span, follow the same steps as defining Start and Stop frequencies by selecting the appropriate parameters from the dropdown menu.

Setting Or Modifying the Resolution and Video Bandwidth

You may change the **Resolution Bandwidth** or the **Video Bandwidth** similar to the way you change frequency parameters. Click **Frequency** on the **Spectrum Analyzer Menu Bar** and then select either, **Resolution Bandwidth** or **Video Bandwidth** from the **Frequency Options** list to open a **Frequency Input** dialog box prompting you for the specific resolution or video bandwidth specifying parameter to be entered. Enter the desired value and then click on the appropriate frequency units for it to take effect.

***Note:** Your change to the **Resolution Bandwidth** may also require you to change the Spectrum Analyzer sweep time. In the event that the choice of a small **Resolution Bandwidth** with a short sweep time results in the Spectrum Analyzer indicating **Measurement Uncal**, either widen the **Resolution Bandwidth** or extend the sweep time. Page ahead to see the Setting Spectrum Analyzer Sweep Time on page 5-6.*

Setting the Reference Level

The reference level permits you to position the **Trace** display such that the largest signal(s) do not exceed the top line of the display. To set the reference level to position the **Trace** display:

1. Click on **Amplitude** on the **Spectrum Analyzer Menu Bar**
2. Select **Reference Level** from the **Amplitude Options** list. This will open the **Amplitude Input** dialog box (Figure 5-5: Typical Amplitude Input Dialog Box) and prompt you to enter a reference level value. Enter the desired reference value in dBm and then click **dB/dBm** for the newly entered value to take effect.

***Note:** As a general guideline for selecting a reference level, use numerically small negative dBm reference values (e.g. -10 dBm representing greater power) for strong signals appearing at or near the top of the display and numerically*

large negative dBm reference values (e.g. -50 dBm representing lesser power) for weaker signals appearing at or near the bottom of the display.

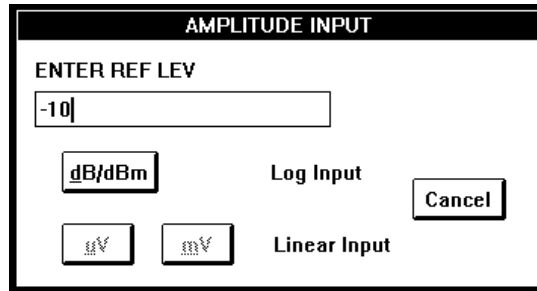

Figure 5-5: Typical Amplitude Input Dialog Box

Setting Attenuation

Control of attenuation permits you to reduce the amplitude of strong signals such that no damage is done to the input mixer of the spectrum analyzer. To set attenuation:

1. Click on **Amplitude** on the **Spectrum Analyzer Menu Bar**
2. Select **Attenuation** from the **Amplitude Options** list, which will open the **Amplitude Input** dialog box and prompt you to enter an attenuation value.
3. Enter the desired attenuation value in dB and then click **dB/dBm** for the newly entered value to take effect.

Figure 5-5 above shows a typical **Amplitude Input** dialog box.

Setting A Threshold

Thresholding permits you to establish signal levels below which signals will not be reported in an actual Monitoring Plan. You have the option of selecting an automatic noise varying threshold or a fixed constant level threshold. To set a threshold:

1. Click on **Amplitude** on the **Spectrum Analyzer Menu Bar**.
2. Select **Threshold** from the **Amplitude Options** list. This opens the **Threshold Options** list.
3. Select **Auto** for an automatic noise varying threshold or, **Set...** to set a fixed constant level threshold. This will open the **Amplitude Input** dialog box (Figure 5-5) and prompt you to enter a fixed **Threshold Level** in dB.
4. Enter the desired threshold level and then click on **dB/dBm** to set the fixed level threshold.

5. To remove the threshold, select **OFF** from the threshold options list.

Note: The threshold indication on the display is a blue horizontal line at the specified fixed level in the case of the **Fixed Threshold** and a blue horizontal line varying with the noise level in the case of the **Auto** threshold.

Setting Spectrum Analyzer Sweep Time

Your Monitoring System has a pre-set Spectrum Analyzer sweep time that you may modify for changed monitoring requirements.

Note: In the event that changes in monitoring requirements (e.g. selecting a small **Resolution Bandwidth**) when using a short sweep time results in the Spectrum Analyzer indicating **Measurement Uncal**, either extend the sweep time or widen the **Resolution Bandwidth**. Page back to see the section **Setting or Modifying the Resolution and Video Bandwidth**.

To change the Spectrum Analyzer Sweep Time:

1. Click on **Sweep** on the **Spectrum Analyzer Menu Bar**.
2. Select **Sweep Time ...** to open the **Time Input** dialog box (Figure 5-6).

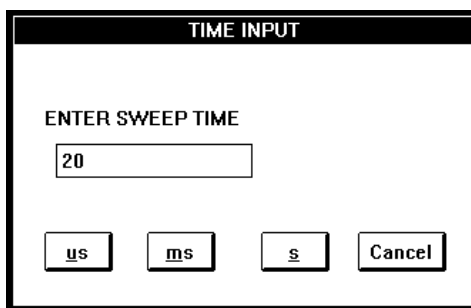

Figure 5-6: Time Input Dialog Box

3. Enter the desired sweep time and click on the appropriate time units for the newly entered sweep value to take effect and to close the Time Input Dialog Box.

Note: Valid sweep times are between 20ms and 60 seconds for the HP 8591E Spectrum Analyzer. See the documentation with your Spectrum Analyzer for specific information on the required settings for sweep times when using other Spectrum Analyzers.

Defining A Monitoring Profile

A monitoring profile defines a power distribution compliance requirement for a carrier. You may define more than one monitoring profile for each carrier by giving it a unique file name and saving it in a specially designated directory for use later in a specific Monitoring Plan.

To define a monitoring **Profile** you must first set up a frequency band in the **Spectrum Analyzer** window that is centered on the carrier to be monitored and having a frequency span that is equal to the frequency range over which you wish to define the Monitoring Profile. You may accomplish this either by selecting and opening an already defined carrier or, by defining an entirely new carrier as previously described beginning with the section for Setting and Modifying Monitoring Band Frequencies on page 5-3.

To define a **Profile**, once you have the required carrier in the **Spectrum Analyzer** window:

1. Click on **Snagl Swp** on the **Spectrum Analyzer** button bar to stop updating the sweep.
2. Click on **Profile** in the **Spectrum Analyzer Menu Bar** to open the **Profile Options List**.
3. From the **Profile Options List** select **Set**. This displays the profile drawing tool.
4. Position the profile drawing tool to the point on the trace display where you want the profile to start and click the left mouse button. Next move the profile drawing tool to the next point of the desired profile and click the left mouse button again.
5. Repeat for additional profile line segments until the required profile has been defined.
6. When done, click the right mouse button to open the **Profile Definition** (Figure 5-1). If the drawn profile is satisfactory, click the left mouse button on **Profile Done**. Click on **Cancel** if you wish to redraw the profile having different characteristics. Clicking the left mouse button on **Profile Done** will change the just drawn profile outline to red.

***Note:** Once a satisfactory profile has been defined you may save it as a profile file for incorporation in one or more Monitoring Plans.*

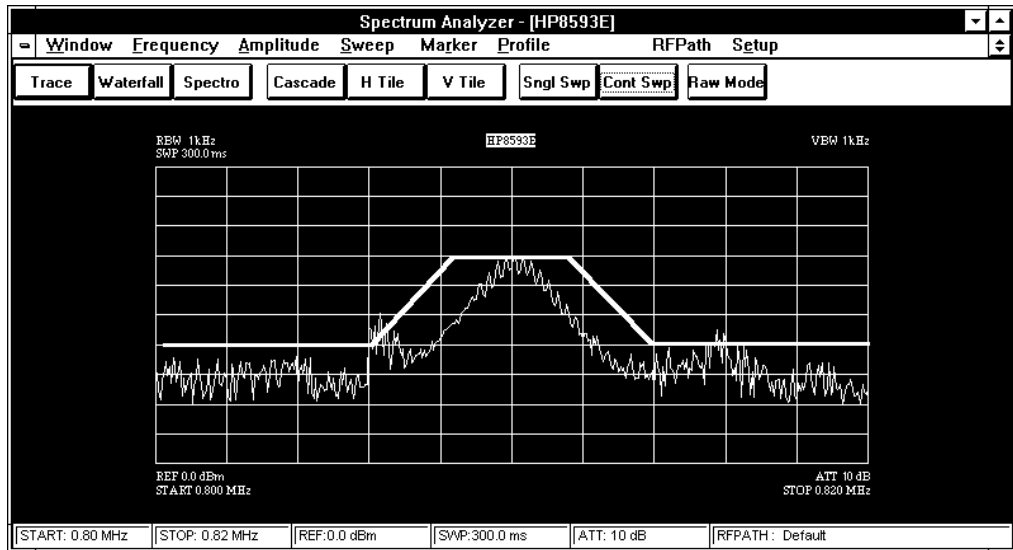

Figure 5-7: Typical Profile Definition for A Carrier

To save the newly defined profile:

1. Click **Profile** on the Spectrum Analyzer **Menu Bar**
2. From the **Profile Options** list select **Save...** to open the **Save Profile** dialog box (Figure 5-8).

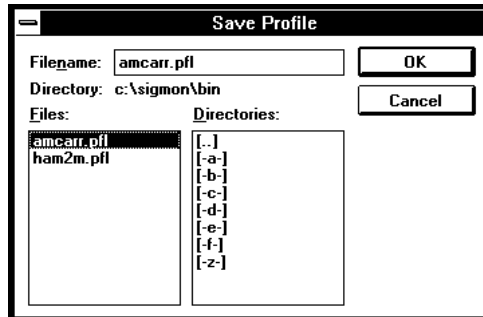

Figure 5-8: Typical Save Profile Dialog Box

3. Enter a descriptive name in the **Filename** box making sure that it retains the **.pfl** file extension
4. Click on **OK**.

Selecting RF Path and Applying Path Gain Correction

Your Monitoring System incorporates multiple RF paths with or without amplification and selectable built in path gain correction capability. To view the effects of RF path and Path Gain correction:

1. Set up a frequency band for monitoring in the Spectrum Analyzer window.
2. Click on **RF Path** on the Spectrum Analyzer **Menu Bar** and then select **Path...** to open the **Select RF Path** list box (Figure 5-9).

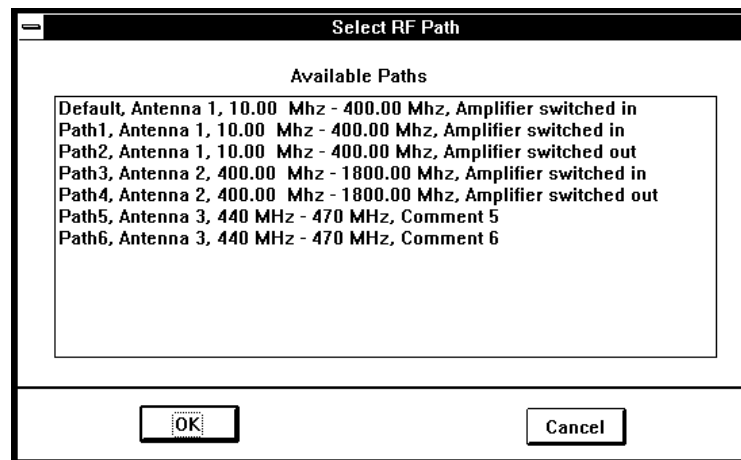

Figure 5-9: Select RF Path List Box

3. Select a path from the **Available Paths** list and click **OK** for the selected path to be activated.
4. To select Path Gain Correction click on **RF Path** on the Spectrum Analyzer **Menu Bar** and then on **Path Gain Correction**. A ✓ will appear next to ✓ **Path Gain Correction** signifying that it is in effect.

Note: The computer displayed trace and amplitude levels may now be different than the spectrum analyzer display, depending on the correction applied. Switching the Path Gain correction Off will result in the same display on the Spectrum Analyzer and the Computer display.

Saving Band Definitions

Once you have defined a monitoring band in terms of frequency, amplitude parameters and RFPath, you may save this monitoring scenario under a unique band name for recall and use at a later time or include it as part of a Monitoring Plan. To save a newly defined band:

1. Click on **Setup** on the Spectrum Analyzer Menu Bar and select **Save...** from the Setup options list to open the Save Settings Dialog Box (Figure 5-10).

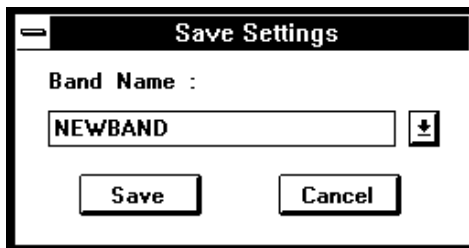

Figure 5-10: Save Settings Dialog Box

2. Enter a descriptive **Band Name**.
3. Click on **Save** to close the Save Settings Dialog Box and save the newly defined frequency band.

Note: You must limit your descriptive signal name to a maximum of 18 characters.

Recalling A Previously Defined Frequency Band.

To recall a previously defined frequency band:

1. Click on **Setup** on the Spectrum Analyzer Menu Bar and select **Recall...** from the Setup options list to open the Recall Settings Dialog Box (Figure 5-11).

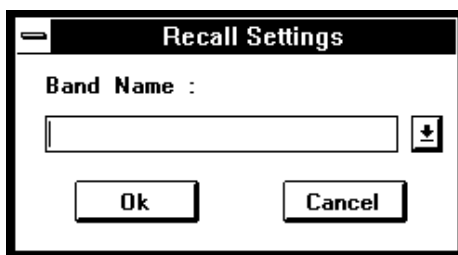

Figure 5-11: Recall Settings Dialog Box

2. Click on the **Arrow Button** to open the available band list. Select the desired band and click on **OK** which will bring up the selected band in the **Sngl Swp** mode and close the Recall Settings Dialog Box.

Performing Carrier Measurements Using the Marker

Performing carrier measurements with the marker requires you to be operating in the **Spectrum Analyzer** window in the continuous sweep mode. This permits you to get a band overview for selecting frequencies of interest on which you may wish to perform a carrier measurement.

***Note:** Carrier measurements using the marker are performed with Spectrum Analyzer parameter values that are specific for a carrier type measured and take effect when you define the type of carrier measurement to be made. These parameter values are preset to default values in your system and may only be modified by a systems administrator as described in Chapter 12 of this manual.*

To perform carrier measurements using the marker:

1. Click on **Marker** in the Spectrum Analyzer Menu Bar and then Select Carrier Type to open the Select Carrier Type Dialog Box (Figure 5-12).

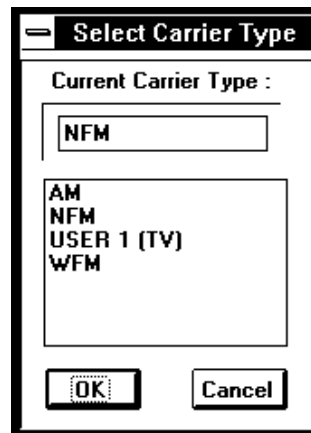

Figure 5-12: Select Carrier Type Dialog Box

2. Select the expected carrier type and click OK.
3. Click on **Marker** in the Spectrum Analyzer Menu Bar and then select **Perform Carrier Measurements** which will activate the **Marker** and position it in the center of the display.
4. Position the mouse pointer to the frequency on which you wish to perform a carrier measurement and click the left mouse button. This will cause the marker to move to that point and to perform a carrier measurement.
5. You may make additional carrier measurements by repeating step 2 as often as required.

***Note:** The Carrier Measurement results performed in this manner are displayed on the main bar and may be viewed using carrier report for band "Bandview."*

Using the Spectrogram

The Spectrogram displays power versus frequency versus time with detected power represented in four power bands, each of which is displayed as a unique color. The power band color representation, with defined power band boundaries, appears at the top of the Spectrogram display. Your Monitoring System comes with the following default settings of the power band boundaries.

Red Signals are	> -60 dBm
Yellow Signals are	> -70 dBm
Green Signals are	≥ -80 dBm
Blue Signals are	Below -80 dBm

To change the power limit settings to suit your individual monitoring environment:

1. Click on any of the individual color definition bars to open the **Spectrogram Setup** dialog box (Figure 5-13).

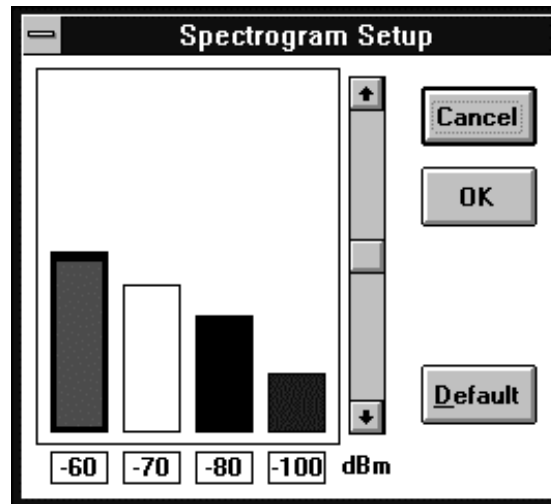

Figure 5-13: Spectrogram Setup Dialog Box

2. Click on the color bar for the power limit that you wish to modify.
3. Click on the up or down arrow on the scroll bar to set the power limit in 10 dBm increments for your application.
4. Repeat for each of the limits as required, and when finished, click OK.

***Note:** Power limits are set in descending power values from left to right and your system will not permit you to reverse this order.*

You may reset your system to the default configuration at any time by opening the **Spectrogram Setup** window, selecting **Default**, and then clicking on OK.

Using the Spectrogram Marker

The **Spectrogram Marker** permits you to select a point anywhere in the **Spectrogram Display** and read out the frequency and time of that power transmission. For the most accurate measurements using the **Spectrogram Marker** you should maximize the Spectrogram Window. To make a measurement:

1. Click on the desired power level anywhere in the **Spectrogram Display** to activate the **Spectrogram Marker**. It appears as a black cross in the display and will cause the frequency and time of the selected point to be displayed under **Marker**, along with the current time, to the left of the **Spectrogram** display.

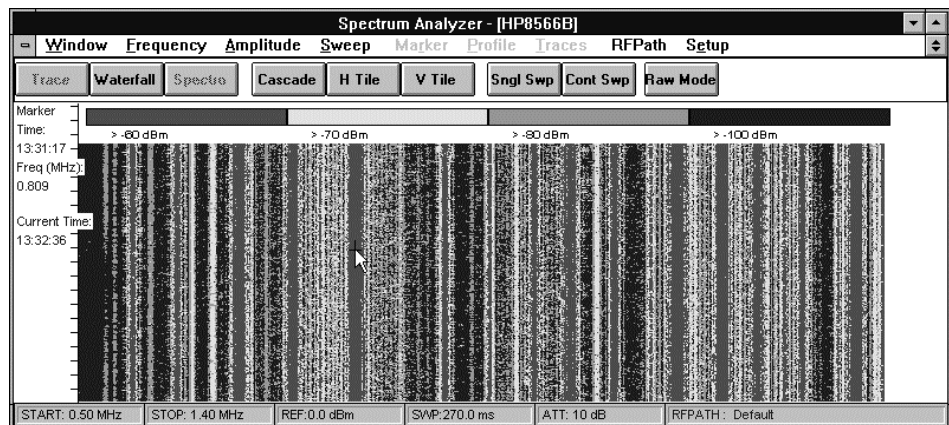

Figure 5-14: Spectrogram With Marker

***Note:** The Spectrogram Marker will remain active as long as the **Spectrogram Window** is open, and remain at the selected point relative to the bottom of the display and at the same frequency until you select another measurement point.*

003

Manual Receiver Handoff

While operating in the Spectrum Analyzer window you have the capability to designate a frequency for aural monitoring by performing a **Manual Receiver Handoff**.

To perform Manual Receiver Handoff:

1. Set up the Spectrum Analyzer to cover the frequency band of interest in the **Cont Swp** mode (see Setting and Modifying Monitoring Band Frequencies on page 5-3).
2. Open the **Receiver Control** dialog box (Figure 5-15) by clicking on **Control** on the **Main Menu** bar and then selecting **Receiver** from the **Control** dropdown menu.

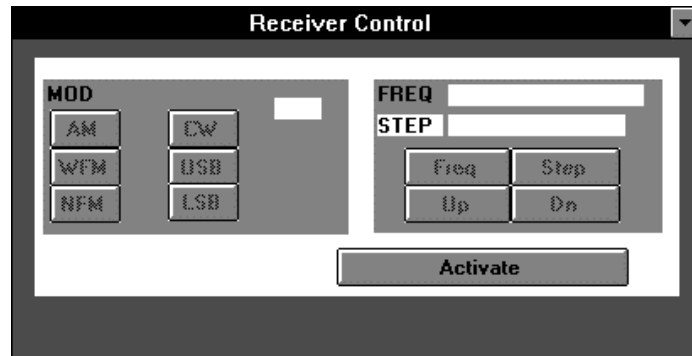

Figure 5-15: Receiver Control Dialog Box

3. Activate the receiver by clicking **Activate** in the Receiver Control dialog box and then select the expected modulation type from the available **Mod** (i.e. modulation) choices and when done, click on the Minimize button to close the Receiver Control Dialog Box.
4. Click on **Marker** on the Spectrum Analyzer **Menu Bar** and then select **Receiver Handoff** which will cause the marker to appear at the center of the monitored band and tune the receiver to this frequency.
5. To tune the receiver to another frequency within the monitored band, position and click the cursor on the new frequency.

Operating the Spectrum Analyzer in Raw Mode

The **Raw Mode** permits you to control the spectrum analyzer by issuing direct **Programming Commands** which are transmitted to the spectrum analyzer over the HP-IB. To issue Programming Commands to the spectrum analyzer make sure you are operating in the **Spectrum Analyzer** window and then:

1. Click on Raw Mode in the Remote Spectrum Analyzer Button Bar to open the Raw Mode dialog box (Figure 5-16).

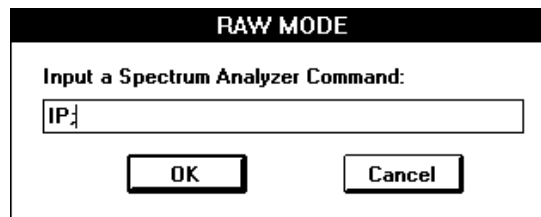

Figure 5-16: Typical Raw Mode Dialog Box

2. Enter an appropriate **Programming Command** in the **Input a Spectrum Analyzer Command Box** and click on **OK** to execute the command.

For example, to preset the spectrum analyzer:

1. Type **IP**; into the Command Box:
2. Click on the **OK** button to execute the command.

***Note:** For a definitive list of **Programming Commands** appropriate for your Spectrum Analyzer, see the applicable revision to the Programmer's Guide, HP 8590D-Series and-E Series Spectrum Analyzer. Hewlett Packard, HP Part No. 5961-6719.*

Closing the Spectrum Analyzer Window

To close the Spectrum Analyzer Window:

1. Click on **Window** in the Spectrum Analyzer Menu Bar.
2. Select **Exit Spectrum Analyzer Mode**.

003

Operating the Receiver and Recorder Manually

Your monitoring system offers you the option to operate the receiver and tape recorder directly and independently of any other monitoring activity.

***Caution:** You must, however, be aware that the last command to the receiver takes precedence in receiver control. i.e. if you switch to manual operation while an alarm handoff to the receiver is in progress the handoff will be terminated and conversely if you are controlling the receiver manually and a Monitoring Plan invokes receiver handoff, your manual receiver control **will** be terminated.*

003

Receiver Control

To gain control of the receiver:

1. Click **C**ontrol on the **Main Menu Bar** and then **R**eceiver to open the **Receiver Control** dialog box (Figure 5-17).

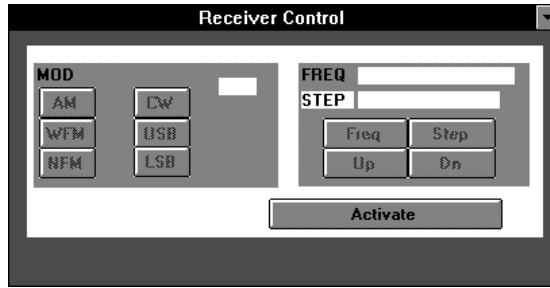

Figure 5-17: Receiver Control Dialog Box

2. Click on **Activate** and then configure the receiver for the type of carrier to be tuned by clicking on the appropriate carrier type listed under **MOD**.
3. You may tune the receiver by setting a starting frequency **FREQ** and step size **STEP** and then clicking **UP** or **DN**.
4. To set the starting frequency or step size, click **Freq** or **Step** to open the corresponding data entry dialog box (Figure 5-18).

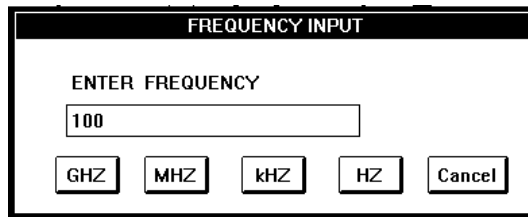

Figure 5-18: Frequency Input Dialog Box

***Note:** The dialog boxes are identical for both frequency and step. Frequency (**Freq**) defines the initial tuned receiver frequency and **Step** defines the up or down frequency step increment that you wish to use while tuning the receiver manually.*

Additionally your Monitoring System offers you the capability to operate the **Tape Recorder** manually to record the currently tuned receiver output or to play back previously recorded material.

***Caution:** You must be aware that the recorder is linked to the receiver when operating in an alarm handoff mode under a Monitoring Plan and will take precedence over your manual receiver operation if it occurs after you started manual tuning. Similarly if an alarm handoff is in progress, taking manual control of the tape recorder will terminate that recording process.*

To gain control of the Tape Recorder:

1. Click **Control** on the Main Menu Bar and then **Tape Recorder** to open the Recorder Control dialog box (Figure 5-19).

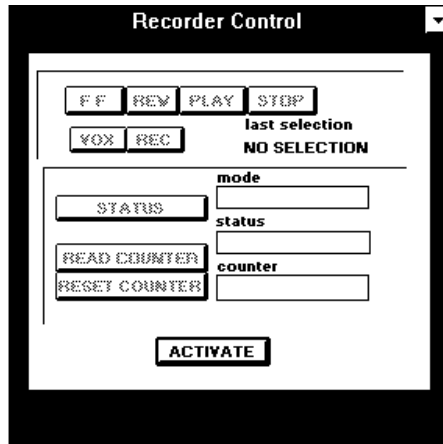

Figure 5-19: Recorder Control Dialog Box

To operate the recorder:

2. Click **Activate** and then perform either recording or playback as required.

003

Recording Control

To record at the beginning of a new tape:

1. Clicking **REW** to make sure that the tape is rewound to the starting position.
2. Click on **Reset Counter** to set the counter to 0000.
3. Tune the receiver to the desired signal.
4. Click on **VOX**.
5. Click on **REC** to start recording.

To record in a voice actuated changeover mode:

1. Set the squelch on the receiver to an appropriate level.
2. Click on **VOX** only.

Note: To view current recorder status and the counter, you must click on **Status** and/or **Read Counter** respectively. These parameters are not updated automatically. The **Last Selection** window displays the last selection made.

4. When sufficient information is recorded, click **STOP** to terminate the recording session.

To play back a pre-recorded tape:

1. Click on **STOP** to make sure that the tape recorder is stopped by.
2. Click either **FF** (Fast Forward) or **REW** (Rewind) to position the tape to the desired starting point

Note: Since the **Counter** window is not updated automatically it is recommended that you monitor tape position on the tape recorder display panel.

3. Click **Play** to start playback.
4. To terminate playback, click **STOP**.

Note: For more detailed instructions on the use of the Tape Recorder, see **ATIS CG-100 Cassette Recorder Operating Instructions**.

Using the Multiple Band Window

You may view up to eight simultaneous display windows in **Multiple Band Window** mode. Each monitored band may be displayed in a **Trace**, **Waterfall**, **Spectrogram**, or all three presentations, subject to the maximum of eight open display windows. Figure 5-20 illustrates the maximum open display window capability, where the system is monitoring four independent bands. Note the additional display types for each of the bands.

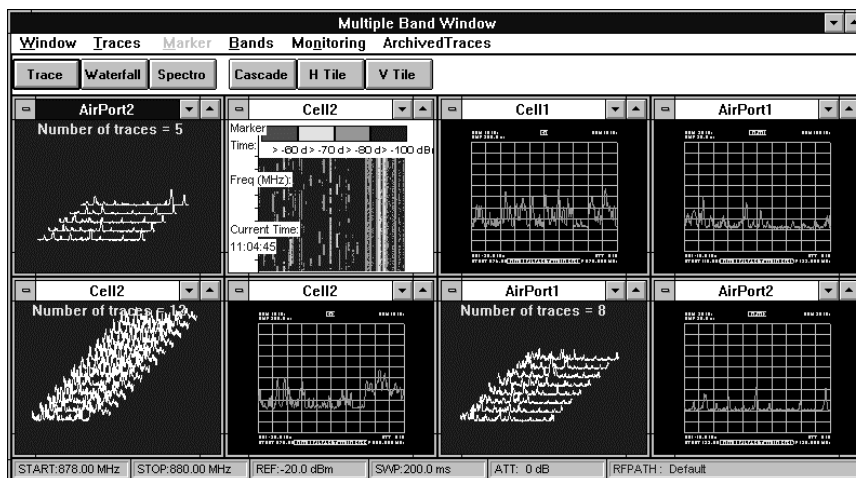

Figure 5-20: Multiple Band View Window With Eight Open Display Windows

Note: While your system does provide you with the capability to monitor up to eight frequency bands simultaneously, it is not recommended to do so in cases where you must view rapidly changing conditions. This is because the bands

selected for simultaneous display are updated sequentially which, with more bands selected, reduces the frequency with which any one of them is processed for display.

Opening the Multiple Band Window:

To open the Multiple Band Window:

1. Click on **V**iew in the **Main Menu Bar** and from the drop down menu select **Multiple Band Window**.

Note: It is recommended that you stop or suspend any Monitoring Plan execution prior to switching to the Multiple Band Window Manager when maximum update rates are required.

2. Click on **B**ands on the **Multiple Band Menu Bar** to open the **Bands** menu and then click on **Select Bands...** to open the **Select Bands** list box (Figure 5-21) displaying all the pre-defined bands available for monitoring.

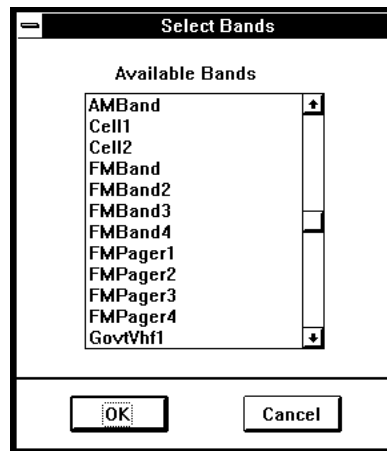

Figure 5-21: Select Bands List Box

3. Select up to eight bands from the **Available Bands** list and then click **OK** to start monitoring.

Note: If a frequency band you wish to monitor is **not** listed as part of the **Available Bands** list, click on **Cancel** to close the **Select Bands** list box and continue with Step 4.

4. After closing the **Select Bands** list box, click on **V**iew in the **Main Menu Bar** and from the drop down menu select **Multiple Band Window**.
5. Click on **D**efine **B**ands on the **Multiple Band Menu Bar** to open the **Band Definition Dialog Box** (Figure 5-22).

The screenshot shows a 'Band Definition' dialog box with the following fields and controls:

- Band Name:** A text input field containing 'NewBand' and a dropdown arrow.
- RF Path:** A dropdown menu set to 'Default' and a 'Select Path' button.
- Start and Stop Frequency:** Two input fields with 'kHz' units, currently empty.
- Center and Span Frequency:** Two input fields with 'kHz' units. 'Center' is set to '810.000' and 'Span' is set to '20.000'.
- Bandwidth/Sweep Time:** Three input fields with units: 'Resolution' (30.000 kHz), 'Video' (10.000 kHz), and 'Sweep Time' (20.000 msec).
- Amplitude:** Two input fields with units: 'Ref Level' (-20.000 dBm) and 'Attenuation' (10.000 dB).
- Detection Mode:** Three radio buttons: 'Sample' (selected), 'Pos Pk', and 'Neg Pk'.
- Buttons:** 'Save', 'Delete', 'Clear', and 'Close' buttons are located at the bottom.
- Warning:** A text box at the bottom right reads: 'WARNING: -10 dBm max signal power @ 0 dB Atten.'

Figure 5-22: Band Definition Dialog Box

6. Enter the parameters required for your new band and click on **S**ave and then **C**lose.
7. To return to the Multiple Band window, click on **V**iew in the **Main Menu Bar** and from the drop down menu select **Multiple Band Window**.
8. Click on **B**ands on the **Multiple Band Menu Bar** to open the **Bands** menu and then click on **S**elect Bands... to open the **Select Bands** list box displaying all the pre-defined bands available for monitoring. The list of bands will contain the new band(s) added by Step 6, above.
9. Select up to eight bands from the **Available Bands** list and then click **OK** to start monitoring.

DISPLAY APPEARANCE

*The selected bands will appear in the **Multiple Band Window** as cascaded windows of frequency **Trace** displays. The last frequency band selected is displayed in a window with a highlighted **Title Bar** and the parameters specific to that band are listed as entries in the **Status Bar** at the bottom of the **Multiple Band window**.*

10. You may alter the display format to a tiled windows type display by clicking on either the **Horizontal Tile** or **Vertical Tile** buttons on the **Multiple Band Window Button Bar**.
11. To enhance the viewing of a monitored band, select that band by clicking in its **Trace Window** display title bar and then the **Waterfall** and/or **Spectrogram** buttons on the **Trace Window Manager Button Bar** to open Waterfall and/or Spectrogram display windows for that band.

***Note:** The maximum number of active open display windows in the **Multiple Band Window** is eight. For more frequent updates it is desirable to minimize the number of open display windows. The optimum update rate occurs when only one window is open and processing.*

Display Optimization

Maximizing the Display Viewing Area

To optimize the viewing of any display format:

1. Select the display window for enhanced viewing by clicking in its **Title Bar**
2. Click on the **Maximize** button in the selected measurement window
3. Click on the **Maximize** button in the **Multiple Band Window** to display the selected measurement as a full screen display.

Changing the Waterfall Display

You have the option to select the number of traces for optimizing your ability to view activity trends in the **Waterfall Display**. To take advantage of this feature:

1. Make the desired **Waterfall Display** the active window by clicking on its title bar.
2. Click on (number of) **Traces** on the **Multiple Band Window Menu Bar**, which will permit you to select a 5, 8 or 12 trace **Waterfall Display**.

***Note:** The default number of traces for a **Waterfall Display** is 12.*

Using the Spectrogram in Multiple Band Window

The **Spectrogram** in Multiple Band Window operates identically as in the Spectrum Analyzer Window. For a description of how to set power limits and use the Spectrogram Marker see the sections **Using The Spectrogram** and **Using The Spectrogram Marker X-REF**.

Using the Marker Option

The Multiple Band Window provides you with the option to use the built in **Marker** to perform selective power and frequency measurements

003

The Multiple Band Window also lets you perform Receiver Handoff on carriers of interest.

Using the Marker

The **Marker** is accessible only when a **Trace Display** is active in the **Multiple Band Window**. For optimum use of the **Marker**, maximize the trace display for a full screen display. To activate the marker, click on **Marker** on the **Multiple Band Window Menu Bar** and then **ON**.

***Note:** The marker appears in a default position at the center of the currently monitored band and rides on the trace displayed.*

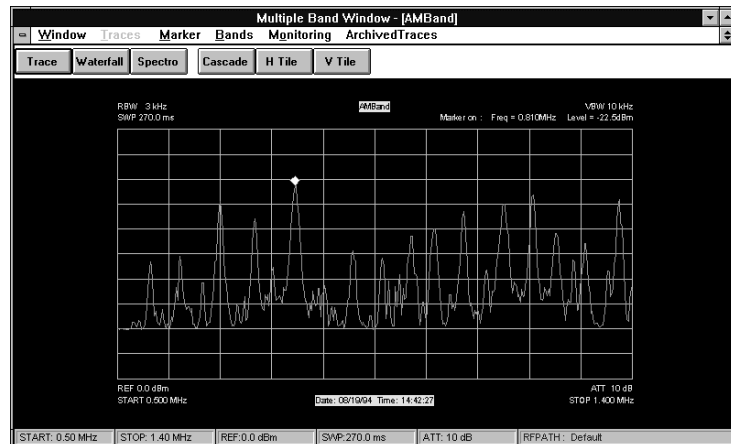

Figure 5-23: Trace View In A Multiple Band Window With Active Marker

To make a frequency and power measurement:

1. Position and click the mouse pointer arrow along the frequency axis.
2. As you place and click the mouse pointer, the Marker will appear on the monitored trace, at that frequency, and provide you with an accurate frequency and power level value for that point in a numerical display at the top of the trace window display.
3. When finished making measurements using the Marker, turn it off by clicking on **Marker** on the **Multiple Band Window Menu Bar** and then select **OFF**.

Performing Receiver Handoff

Receiver Handoff in the Multiple Band Window is performed as it was done in the Spectrum Analyzer Window. To perform **Receiver Handoff**, open a frequency band of interest and then:

1. Open the **Receiver Control** dialog box (Figure 5-24) by clicking on **Control** on the **Main Menu** bar and then selecting **Receiver** from the **Control** dropdown menu.

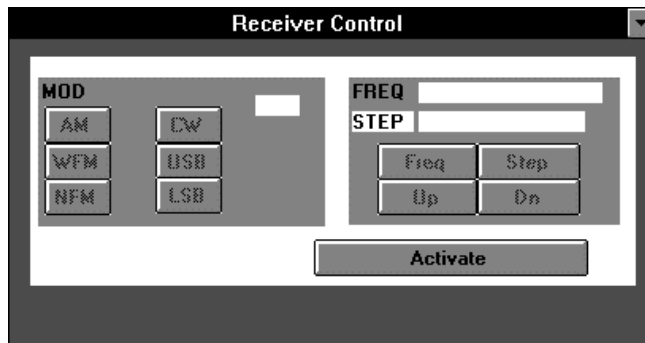

Figure 5-24: Receiver Control Dialog Box

2. Activate the receiver by clicking **Activate** in the Receiver Control dialog box and then select the expected modulation type from the available **Mod** (i.e. modulation) choices and when done click on the Minimize button to close the Receiver Control Dialog Box.
3. Click on **Marker** on the **Multiple Band Window Menu Bar** and then select **Receiver Hand-off** which will cause the marker to appear at the center of the monitored band and tune the receiver to this frequency.
4. To tune the receiver to another frequency within the monitored band, position and click the cursor on the new frequency.
5. When finished, click on **Marker** on the **Multiple Band Window Menu Bar** and then deselect **Receiver Hand-off**.

Controlling the Multiple Band Window

Once you have started monitoring you may **Suspend**, **Resume**, or **Stop Monitoring**

1. Click on **M^onitoring** on the **Multiple Band Window Menu Bar**
2. Select the appropriate control choice from the dropdown list.

Viewing Archived Traces

The **Multiple Band View Window** provides you with the capability to view traces that were logged to the data base as a result of alarm actions or regular logging defined under the Monitoring Plans.

To view previously logged traces:

1. Click on **ArchivedTraces** on the **Multiple Band Window** Menu Bar to open the **Trace View** Dialog Box (Figure 5-25):

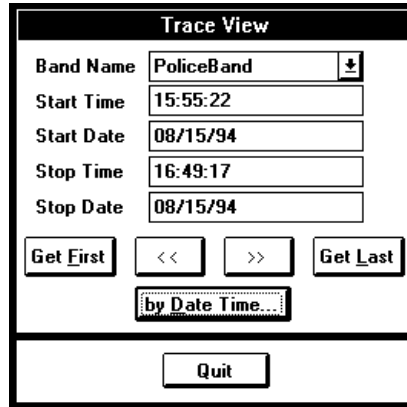

Figure 5-25: Trace View Dialog Box

2. Select a frequency band of interest and review the stored trace data for the date and time shown by clicking on either **Get First** or **Get Last** and then scroll through logged traces by clicking on << or >> as appropriate.
3. If you would like to review logged traces of another date and time, then click on **by Date Time** to open the **By Date Time** dialog box (Figure 5-26).

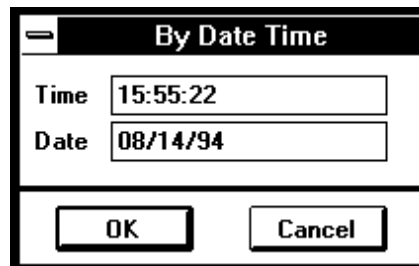

Figure 5-26: By Date Time Dialog Box

4. Enter the desired time and date and click **OK**.
5. When finished reviewing stored traces, click on **Quit** in the **Trace View** Dialog Box.

Monitoring Under A Plan

Your Monitoring System offers you the capability to perform monitoring under a pre-defined Monitoring Plan or plans. A Monitoring Plan is a definition of a monitoring task that includes the definition of a frequency band or bands to be monitored and links these frequency definitions with measurements to be performed. Additionally, the Monitoring Plan may include the definition of measurement thresholds, signal masks for excluding signals from consideration and alarm condition definitions for specific actions, such as receiver and tape recorder handoff.

Once defined, you may activate a Monitoring Plan at any time directly, or you may schedule it to operate at specific times on specific dates.

Creating A Monitoring Plan

The creation of a Monitoring Plan includes the following major steps:

- Definition of a Frequency Band or Bands
- Definition of a Measurements.
- Definition of Alarms and Signal Masks
- Assembling the Monitoring Plan.

Defining Frequency Bands

The definition of a frequency band for a Monitoring Plan is identical to the one used for the Multiple Band View window. To define a new frequency band:

1. Click on **Setup** on the main menu bar and select **Band Definition...** from the Setup options list to open the **Band Definition** Dialog Box (Figure 6-1).

Figure 6-1: Band Definition Dialog Box

2. Enter a descriptive name in the **Band Name** edit box.

Note: You must limit your descriptive band name to a maximum of 18 characters.

3.  Select an **RF Path** by clicking on **Select Path** to open the **Select RF Path** dialog box (Figure 6-2), select a path from the **Available Paths** list and then click **OK**.

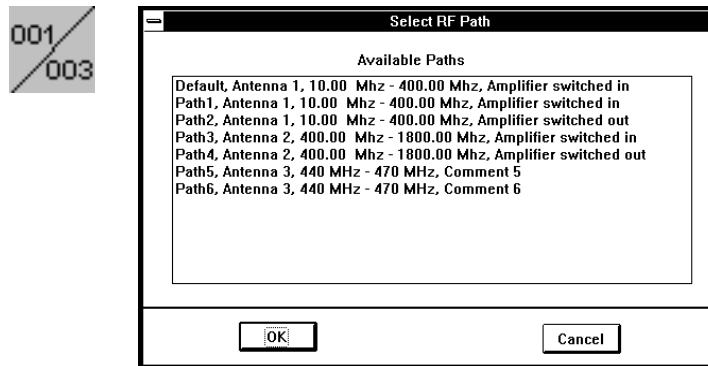

Figure 6-2: Select RF Path List Box

4. Define the frequency of the band by either :
 - clicking on the **Start and Stop Frequency** radio button and entering the **Start and Stop** frequency

OR

 - clicking on the **Center and Span Frequency** radio button and entering the **Center and Span** frequency.

Note: When defining bands for Occupancy or Statistical measurements you must take into account the Spectrum Analyzer's specified accuracy and the required channel spacing to set the maximum span of the band to be monitored. For detailed instructions on how to set up monitoring bands for these applications see *Setting Start/ Stop Frequencies For Channelized Measurements* below.

5. Enter **Resolution, Video** and **Sweep Time** parameters in the **Bandwidth/Sweep Time** edit box.
6. Set the **Ref Level** and **Attenuation** in the **Amplitude** edit box.
7. Set the **Detection mode** by clicking either **Sample** or **Pos Pk**.

Caution: Do not select **Neg Pk** when using your HP 8591E Spectrum Analyzer or any of the HP 8590 Series Spectrum Analyzers. Selection of **Neg Pk** will cause the detection mode to default to **Sample**.

MEASUREMENT TIP-Selecting Detection Mode

Selection between Sample, Positive Peak, and Negative Peak detection modes is important if the spectrum monitoring system is being used for carrier measurements. It is not critical for occupancy measurements or for signal logging of power and frequency data.

Sample detection is best for measuring noise signals where the signal content is not a CW signal and it is desired to have a display that represents the randomness of noise as displayed on the spectrum analyzer display. Signal-to-Noise measurements will be more accurate if made using the Sample detection mode

Positive Peak is best for ensuring that the maximum value of all CW signals is displayed on the spectrum analyzer display. It is particularly useful when the spectrum analyzer is operating with wide spans and narrow resolution bandwidths since a Positive Peak detector will capture the true maximum value of the carrier and not be limited by the digital display process. The power values reported in the Signal Logging process will be more accurate using Positive Peak detection.

Negative Peak detection is best for capturing the maximum negative values of random signals (Noise). It is included as a selection choice for completeness, but is not likely to be used very often.

8. Verify that the entered values and selections are correct and click on **Save**.
9. Repeat steps 2 through 8 for additional required bands and when finished, click on **OK** to close **Band Definition** window.

Setting Start/ Stop Frequencies For Channelized Measurements

In order to get meaningful Occupancy and Statistical measurement results you must select band Start and Stop frequencies that take into account the spectrum analyzer span accuracy of 2% and the channel spacing for your application. (The Span Accuracy determines the maximum number of channels that can be correctly assigned to their right channel number.)

To set Lower and Upper band limits for your application, you must first determine the maximum permissible frequency span that can be used with your required channel spacing. You may determine the span as follows:

$$\text{Maximum Span} \leq \frac{\text{Channel Spacing}}{0.02}$$

From this it can be seen that the maximum number of channels that you may monitor in a given band is ≤ 50 . If your application requires you to monitor more than 33 channels then it is recommended that you divide the band into sub-bands of acceptable span width. The following relationships permit you to define proper band Start and Stop Frequencies.

The lower or Start Frequency is determined as:

$$\text{Start Frequency} = \text{Lowest Channel Center Frequency} - \frac{\text{Channel spacing}}{2}$$

The upper or Stop Frequency is determined as:

$$\text{Stop Frequency} = \text{Highest Channel Center Frequency} + \frac{\text{Channel Spacing}}{2}$$

Defining Measurements

Your Monitoring System permits you to define four measurement types that can be tailored to support your specific monitoring task. To define a measurement based on any one of these measurement types, click on **Setup** on the main menu bar and select Measurement Definition to open the **Measurement Definition** drop down menu (Figure 6-3).



Figure 6-3: Measurement Definition Menu

Select the measurement type to open the required measurement definition dialog box.

Setting Up Signal Logging Measurements

1. Click on **Signal Logging** in the **Measurement Definition** menu to open the Signal Logging Definition dialog box (Figure 6-4).

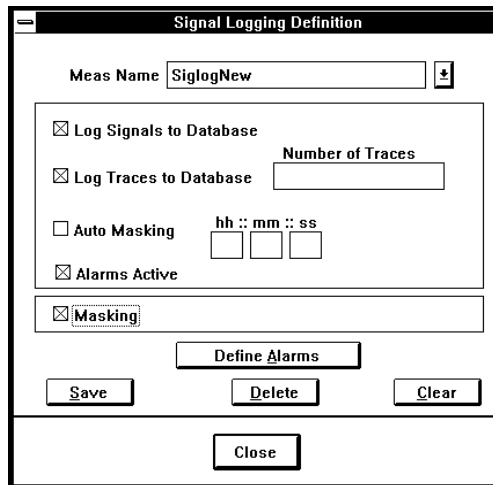

Figure 6-4: Signal Logging Definition Dialog Box

2. Enter a descriptive measurement name in the **Meas Name** edit box.
3. Define signal logging destination by clicking either on **Log Signals to Database** or **Log Traces to Database**. (If the **Log Traces** option is selected then enter the number of traces to be logged in the **Number of Traces** dialog box.).
4. If you wish to exclude certain frequencies from monitoring then enable masking by clicking on the **Masking** Button.

Note: For a description of how to set up signal masks, see the Chapter 12: System Administration.

5. If you wish to eliminate repeated logging of a signal or signals during a specific time interval, then select **Auto Masking** and enter a value for **hh:mm:ss** to define the time period during which you wish to log only the first occurrence of a signal.
6. To define alarms, click on the **Define Alarms** button to open the **Signal Logging Alarm Definition** dialog box.

Note: Alarms may be set to detect when a signal falls between two frequency limits or between two frequency limits and an upper or lower detected power level.

7. Check the **Frequency** and **Power** boxes. The Frequency box must always be checked, but the Power box is optional. Enter the corresponding parameters (Figure 6-5).

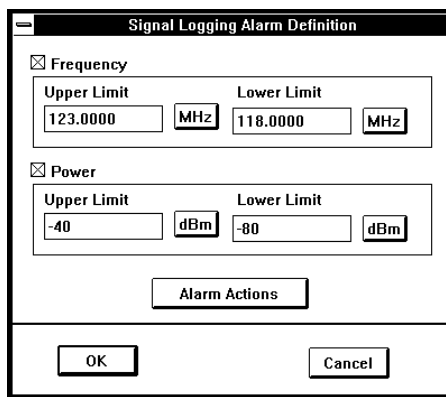

The dialog box titled "Signal Logging Alarm Definition" contains two checked sections: "Frequency" and "Power". The "Frequency" section has "Upper Limit" set to 123.0000 MHz and "Lower Limit" set to 118.0000 MHz. The "Power" section has "Upper Limit" set to -40 dBm and "Lower Limit" set to -80 dBm. Below these sections is an "Alarm Actions" button. At the bottom of the dialog are "OK" and "Cancel" buttons.

Figure 6-5: Signal Logging Alarm Definition Dialog Box

8. Verify that the limits entered are correct and click on **Alarm Actions** to open the Alarm Actions Definition Dialog Box (Figure 6-6 and Figure 6-7).

E
001

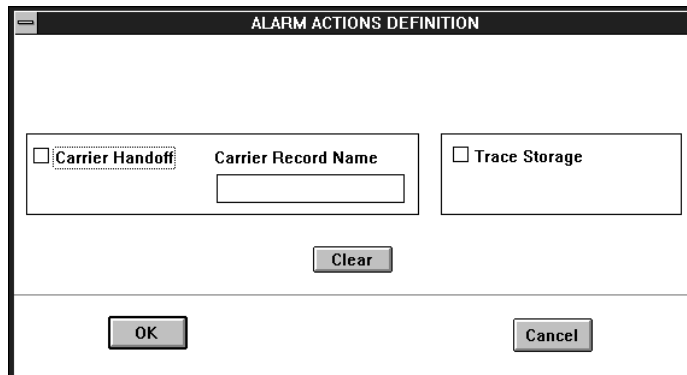

The dialog box titled "ALARM ACTIONS DEFINITION" contains two options: "Carrier Handoff" and "Trace Storage". The "Carrier Handoff" option is checked and has a "Carrier Record Name" text box next to it. The "Trace Storage" option is unchecked. Below these options is a "Clear" button. At the bottom of the dialog are "OK" and "Cancel" buttons.

Figure 6-6: E4900 and Option 001 Alarm Actions Definition Dialog Box

1. **E 001** Select either **Carrier Handoff** and/or **Trace Storage** as alarm actions and then select the appropriate parameters for each.

003

The screenshot shows a dialog box titled "ALARM ACTIONS DEFINITION". It has three sections, each with a checked checkbox:

- Receiver Handoff**: Includes a "Receiver Name" dropdown menu with "Rx1" selected and a "Modulation Type" dropdown menu with "NFM" selected.
- Carrier Handoff**: Includes a "Carrier Record Name" text box containing "TestCase".
- Trace Storage**: A checked checkbox.

 At the bottom of the dialog are buttons for "Clear", "OK", and "Cancel".

Figure 6-7: Option 003 Alarm Actions Definition Dialog Box

10. **003** Select either, **Receiver Handoff**, **Carrier Handoff** or **Trace Storage** as alarm actions and then select the appropriate parameters for each.

003 If you checked **Receiver Handoff**, you must select a Receiver from the **Receiver Name** list and a Modulation Type from the **Modulation Type** list (Figure 6-8).

003

The screenshot shows a list titled "Modulation Type". The list items are:

- CW
- AM
- NFM
- WFM
- CW** (highlighted with a black background)
- USB
- LSB

 A small arrow icon is visible to the right of the top CW entry.

Figure 6-8: Available Modulation Type List

003 ***Note:** The HP E4900 features Priority Handoff on alarmed signals. An alarm on a signal, or band, that is assigned Priority 1 takes precedence over other signals, and so on. If no signals or bands have been assigned a priority, then alarmed signals will be handed off in the order received. Queuing takes place if necessary. Default recording time for each signal is 30 seconds, assuming an alarm is not generated by a higher priority signal. Information on defining Receiver Handoff Priority and setting the default recording time is described in Chapter 12 on System Administration.*

If you checked **Carrier Handoff** you must enter a descriptive name in the **Carrier Record Name** edit box.

Note: Checking Carrier Handoff Causes a carrier measurement to be made on the signal that caused the alarm and the result to be logged to a data file entered in the **Carrier Record Name** edit box, which you may later view using Carrier Report. (See Chapter 12 for controlling system administrator settings used for a carrier handoff alarm in the MHOS.INI).

If you checked **Trace Storage**, a trace will be logged to the database each time that an alarm condition occurs. The trace will be logged to a file carrying the same name as the band in which the alarm occurred.

11. After the required Alarm Actions have been selected, click **OK** to return to the Signal Logging Alarm Definition Dialog Box, click **OK** to return you to the **Signal Logging Definition** dialog box and then click on **Save**.
12. If you would like to define additional Signal Logging Measurements, repeat steps 2 through 10 and when finished click on **OK** to close the Signal Logging Measurement dialog box.

Setting Up Carrier Measurements

Carrier Measurements are performed on specific frequencies, not frequency bands, and as such may be thought of as narrow band measurements to determine Maximum and Average Power, Signal to Noise and Occupied Bandwidth.

To set up a carrier measurement:

1. Click on **Carrier...** in the Measurement Definition menu to open the **Carrier Measurement Definition** dialog box (Figure 6-9).

The screenshot shows the 'Carrier Measurement Definition' dialog box. The 'Measurement Name' field contains 'CarrNew'. The 'Standard Measurements' section is checked and includes 'Center Frequency', 'Maximum Power', 'Average Power', 'Signal/Noise', and 'Occupied Bandwidth'. The 'dB Down' field is set to 26 dB and the 'Width' field is set to 20 kHz. The '% Amplitude Modulation' and 'Profile Compliance' checkboxes are also checked. On the right, the 'Alarms Active' checkbox is checked, and there are buttons for 'Clear', 'Delete', 'Define Alarms', and 'Save'. A 'Close' button is located at the bottom right.

Figure 6-9: Carrier Measurement Definition Dialog Box

2. Enter a descriptive measurement name in the **Measurement Name** edit box.
3. Select the measurement or measurements to be performed by checking either **Standard Measurements**, **% Amplitude Modulation**, **Profile Compliance** or all of the measurement boxes.

***Note:** Your Monitoring System includes default values for dB Down and Width. For guidelines in setting up a Carrier Measurement, see the Carrier Measurements Monitoring Tip for setting the “dB down” and “width” parameters.*

4. If you require dB Down and Width values other than the default provided, then enter the new values in the **dB Down** and **Width** boxes for the measurement of occupied bandwidth.

Monitoring Tip - Carrier Measurements, setting the “dB down” and “Width” values

The carrier measurement algorithms are designed to work with the spectrum analyzer center frequency set to the expected frequency of the carrier to be monitored and span set to zero MHz. It is necessary to know what type of signal is being monitored to enter valid values of “dB down” and “Width” (i.e. bandwidth). The algorithm for occupied bandwidth centers the signal, and then determines how far from the measured center frequency there are sidebands present at x dB down where “x” equals a value entered by the user. This value is then used to calculate occupied bandwidth.

For example, assume an AM modulated broadcast signal was to be measured. FCC Rules and Regulations state that the occupied bandwidth at 25 dB down must be less than 30 kHz. To check compliance, set the “dB down” user entry box to 25 dB and set the bandwidth to 50 kHz - which will be the span used by the spectrum analyzer. (50 kHz will be enough to capture sideband frequencies of up to 25 kHz which should be a sufficient guard band). It is important not to enter a value of bandwidth that would result in a spectrum analyzer span that covers more than one broadcast signal since adjacent sidebands will be erroneously measured.

Similarly, for an FM modulated broadcast signal, where the maximum frequency deviation allowed under FCC Rules and Regulations is 75 kHz and the highest modulating frequency is assumed to be 15 kHz, then it can be shown that the modulation index = 5 and there will be eight significant sideband pairs. Therefore, the occupied bandwidth equals $2 \times 8 \times 15 = 240$ kHz. “Significant sideband pairs” means not more than 40 dB down from the amplitude of the unmodulated carrier. To check compliance, set the dB down user entry box to 40 dB and set the bandwidth to 400 kHz.

In each case, the monitoring system will measure the occupied bandwidth and record that value for display in the Carrier Report. (The report includes other parameters such as maximum power and center frequency of the carrier being monitored.)

Note that the above user entered numbers do not take into account an allowance for system measurement uncertainties which would be mainly spectrum analyzer based. For information on spectrum analyzer accuracy, refer to the appropriate instrument specifications in the data sheet and other supporting information such as the manual.

5. If alarm definition is required, click on **Define Alarms** to open the **Carrier Measurement Alarm Select** dialog box (Figure 6-10).

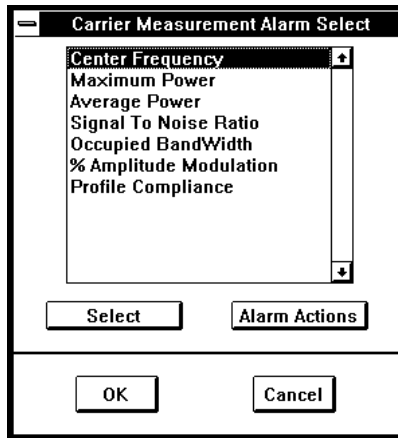

Figure 6-10: Carrier Measurement Alarm Select Dialog Box

6. Select the desired Carrier Measurement Alarm by highlighting it in the **Carrier Measurement Alarm** list and then click on **Select** to open the corresponding alarm definition dialog box, define the applicable alarm parameters and then, if required, click on **Alarm Actions** to open the **Alarm Actions Definition** dialog box (Figure 6-11 and Figure 6-12).

Note: For examples on how to define Carrier Measurement Alarms, see the subsequent section Setting Carrier Measurement Alarms.

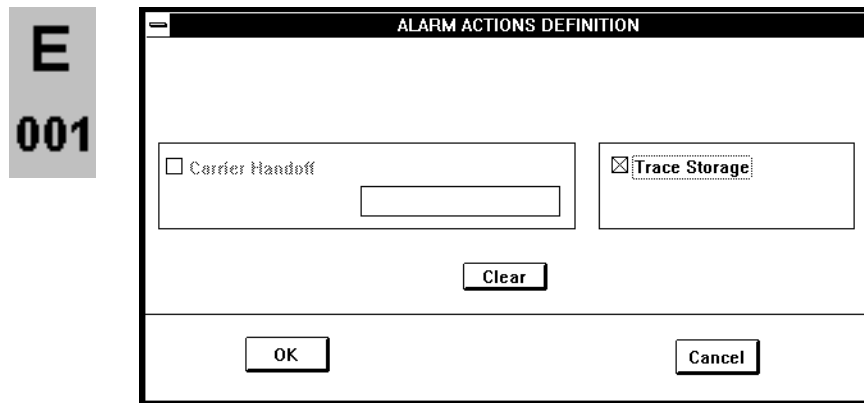

Figure 6-11: E4900 and Option 001 Alarm Actions Definition Dialog Box

003

The screenshot shows a dialog box titled "ALARM ACTIONS DEFINITION". It contains the following elements:

- Receiver Handoff: A checkbox followed by a "Receiver Name" text box and a "Modulation Type" dropdown menu.
- Carrier Handoff: A checkbox followed by a "Carrier Record Name" text box.
- Trace Storage: A checkbox.
- A "Clear" button centered below the input fields.
- "OK" and "Cancel" buttons at the bottom.

Figure 6-12: Option 003 Alarm Actions Definition Dialog Box

7. **E 001** Select **Trace Storage** as the alarm actions by checking the appropriate selection box.
8. **003** Select either, **Receiver Handoff**, or **Trace Storage**, or both as alarm actions by checking the appropriate selection box or boxes.

003

If you checked **Receiver Handoff**, you must select a Receiver from the **Receiver Name** list and a Modulation Type from the **Modulation Type** list.

***Note:** The HP E4900 features Priority Handoff on alarmed signals. An alarm on a signal, or band, that is assigned Priority 1 takes precedence over other signals, and so on. If no signals or bands have been assigned a priority, then alarmed signals will be handed off in the order received. Queuing takes place if necessary. Default recording time for each signal is 30 seconds, assuming an alarm is not generated by a higher priority signal. Information on defining Receiver Handoff Priority and setting the default recording time is described in Chapter 12 on System Administration.*

If you checked **Trace Storage**, a trace will be logged to the database each time that an alarm condition occurs. The trace will be logged to a file carrying the same name as the band in which the alarm occurred.

9. After the required Alarm Actions have been selected, click **OK** to return to the **Carrier Measurement Alarm Select Dialog Box**, click **OK** to return you to the **Carrier Measurement Definition** dialog box and then click on **Save**.
10. If you would like to define additional **Carrier Measurements**, then repeat steps 2 through 8, and when finished, click on **Close** to close the Carrier Measurement Dialog Box.

Setting Carrier Measurement Alarms

Carrier measurement alarms, when set, detect when certain limits of a specific carrier measurement are exceeded and log the occurrences to an **Alarm Log**. You are provided with the capability to set the limits to trigger seven types of alarms. To set the parameters for a specific alarm you must select that alarm in the **Carrier Measurement Alarm Select** dialog box which opens the corresponding **Alarm Definition** dialog box.

The following figures (Figure 6-13 through Figure 6-19) are typical examples of each of the seven possible **Carrier Alarm** definition dialog boxes:

Center Frequency Alarm Definition

Center frequency alarm definition involves the setting of a Delta Frequency which is a limit within which a carrier may drift without generating an alarm.

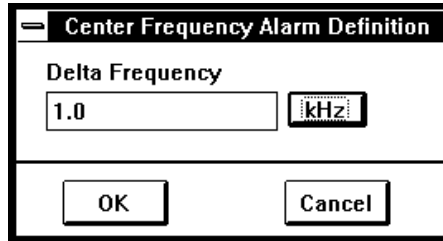

The dialog box is titled "Center Frequency Alarm Definition". It features a text input field containing "1.0" and a unit selector dropdown menu set to "kHz". At the bottom, there are two buttons: "OK" and "Cancel".

Figure 6-13: Typical Center Frequency Alarm Definition Dialog Box

Maximum and Average Power Alarm Definition

Maximum and Average Power Alarm definition involves the setting of Upper and Lower Power limits and offers you three choices for triggering alarms. You may elect to have an alarm generated whenever the measured power occurs either below the lower limit, between the specified limits or above the upper limit.

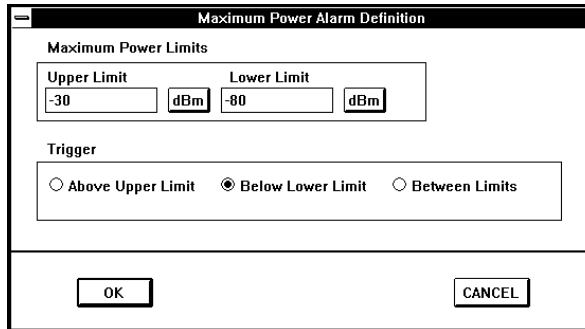

The dialog box is titled "Maximum Power Alarm Definition". It has two main sections. The first, "Maximum Power Limits", contains two input fields: "Upper Limit" with the value "-30" and unit "dBm", and "Lower Limit" with the value "-80" and unit "dBm". The second section, "Trigger", contains three radio button options: "Above Upper Limit", "Below Lower Limit" (which is selected), and "Between Limits". At the bottom, there are two buttons: "OK" and "CANCEL".

Figure 6-14: Typical Maximum Power Alarm Definition Dialog Box

Figure 6-15: Typical Average Power Alarm Definition Dialog Box

Signal To Noise Alarm Definition

Signal to Noise alarm definition involves the selection of a S/N limit in dB to trigger an alarm whenever the measured signal to noise ratio falls below this limit.

Figure 6-16: Typical Signal To Noise Alarm Definition Dialog Box

Occupied Bandwidth and % AM Limits Alarm Definition Dialog Box

Occupied Bandwidth Alarm and % Amplitude Modulation Limits Alarm Definition are similar since they involve the specification of an upper and lower occupied bandwidth and an upper and lower limit for % Amplitude Modulation respectively for each measurement and offer you three choices for triggering alarms. You may elect to trigger an alarm whenever the applicable measurement falls below a limit, above a limit or falls between the limits.

Figure 6-17: Typical Occupied Bandwidth Alarm Definition Dialog Box

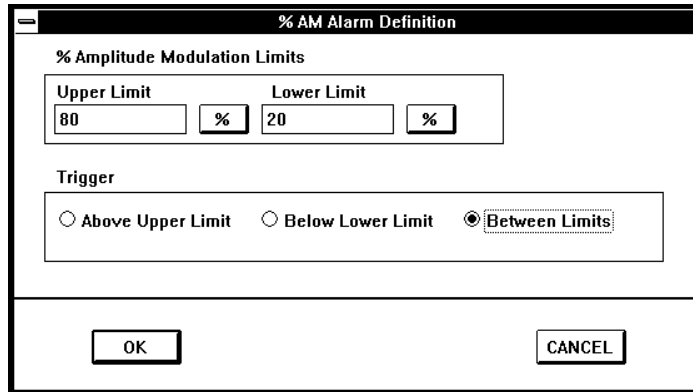

Figure 6-18: Typical % AM Alarm Definition Dialog Box

Profile Compliance Alarm Definition Dialog Box

***Note:** Profile Compliance is the result of a pass/fail check on a trace against a user entered profile. 100% Profile Compliance means no part of the displayed trace exceeded the selected limit. Less than 100%, for example 80% Profile Compliance, means that 20% of the displayed trace points exceeded the profile.*

Profile Compliance Alarms may be set only if profile compliance has been invoked when setting up the **Carrier Measurement** and involves the specification of **% Profile Compliance**. An alarm will be generated whenever the carrier measurement falls below this limit.

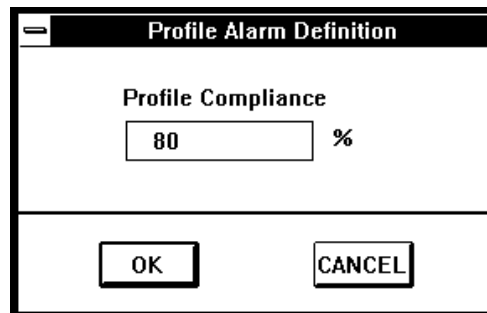

Figure 6-19: Typical Profile Compliance Alarm Definition Dialog Box

Setting Up Occupancy Measurements

1. To open the **Occupancy Measurement Definition** dialog box (Figure 6-20), in the measurement definition menu, click on **Occupancy**.

The dialog box is titled "Occupancy Measurement Definition". It contains the following elements:

- Meas Name:** A text box containing "OccNew" and a dropdown arrow.
- Channel Spacing:** A text box containing "25" and a unit selector box containing "kHz".
- Interval Occupancy:** A checked checkbox, a text box containing "10", and the unit "min".
- Alarms Active:** A checked checkbox.
- Masking:** A checked checkbox.
- Buttons:** "Define Alarms", "Save", "Delete", "Clear", and "Close".

Figure 6-20: Occupancy Measurement Definition Dialog Box

2. Enter a descriptive measurement name in the **Meas Name** edit box and if there are frequencies that you wish to exclude, then check the **Masking** box.

***Note:** For a description of how to set up signal masks, see Chapter 12: System Administration.*

3. Determine and enter the value for channel spacing in the **Channel Spacing** edit box.

***Note:** The channel spacing must be selected to be consistent with the frequency span for the band to be monitored. For instructions how to set up frequency bands for occupancy measurements see Setting Start/ Stop Frequencies For Channelized Measurements on page 6-3.*

4. If you would like to measure and log interval occupancy then check the **Interval Occupancy** box and enter a corresponding time interval in the **Interval Occupancy** Edit Box.

***Note:** In the case of Interval occupancy, data is collected over a series of time periods with one data point per channel for each time interval. The default occupancy measurement is running occupancy where data is collected over a single user specified period of time. One data point per channel is collected for the total time period.*

5. If alarm reporting is required then open the **Occupancy Alarm Definition** dialog box (Figure 6-21) by clicking on the **Define Alarms** button.

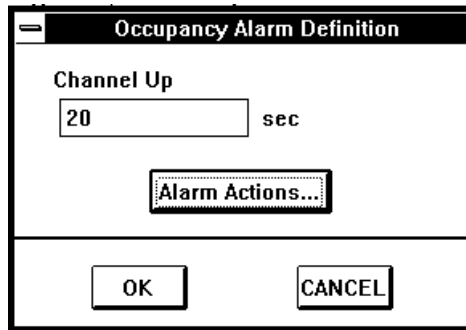

Figure 6-21: Typical Occupancy Alarm Definition Dialog Box

6. An alarm condition is defined as being true when signal presence is greater than Channel Up time.
7. Complete the alarm definition by entering a **Channel Up** time between 1 and 200 seconds. If only alarm logging is required but no alarm actions (e.g. Receiver Handoff or Trace Storage) are desired, click **OK**.
8. If alarm actions are required, click on **Alarm Actions...** to open the **Alarm Actions Definition Dialog Box** (Figure 6-22 and Figure 6-23).

**E
001**

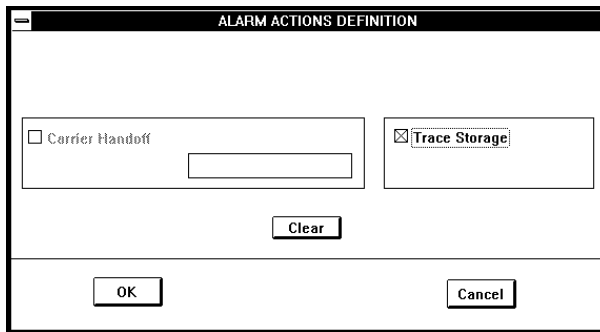

Figure 6-22: Alarm Actions Definition Dialog Box

9. **E 001** Select **Trace Storage** as the alarm actions by checking the appropriate selection box.

003

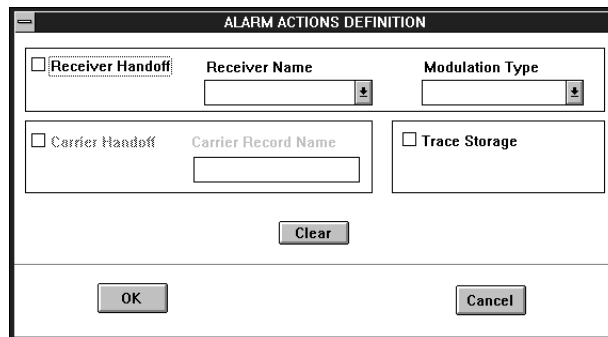

Figure 6-23: Alarm Actions Definition Dialog Box

003 Select either, **Receiver Handoff** or **Trace Storage** or both as alarm actions by checking the appropriate selection box or boxes.

003 If you checked **Receiver Handoff**, you must select a Receiver from the **Receiver Name** list and a Modulation Type from the **Modulation Type** list.

003 ***Note:** The HP E4900 features Priority Handoff on alarmed signals. An alarm on a signal, or band, that is assigned Priority 1 takes precedence over other signals, and so on. If no signals or bands have been assigned a priority, then alarmed signals will be handed off in the order received. Queuing takes place if necessary. Default recording time for each signal is 30 seconds, assuming an alarm is not generated by a higher priority signal. Information on defining Receiver Handoff Priority and setting the default recording time is described in Chapter 12: System Administration.*

If you checked **Trace Storage**, a trace will be logged to the database each time that an alarm condition occurs. The trace will be logged to a file carrying the same name as the band in which the alarm occurred.

11. After the required Alarm Actions have been selected, click **OK** to return to the **Occupancy Alarm Definition** dialog box.
12. Click **OK** again to return to the **Occupancy Measurement Definition** dialog box.
13. Click on **Save** to complete the Occupancy Measurement Definition.
14. If you would like to define additional **Occupancy Measurements**, then repeat steps 2 through 10, and when finished, click on **Close** to close the Occupancy Measurement Dialog Box.

Setting Up Statistical Measurements

Statistical measurements are intended for the collection of channel power and/or channel availability statistics. There is no display window associated with statistical measurements other than the indication on the **Status Bar** that a statistical measurement is being performed. To set up a statistical measurement:

1. In the measurement definition menu, click on **Statistical...** which opens the **Statistical Signal Measurement** dialog box (Figure 6-24).

Figure 6-24: Statistical Measurement Definition Dialog Box

2. Enter a descriptive measurement name in the **Meas Name** edit box.
3. Determine and enter the value for channel spacing in the **Channel Spacing** edit box.

***Note:** The channel spacing must be selected to be consistent with the frequency span for the band to be monitored. For instructions how to set up frequency bands for occupancy measurements see *Setting Start/ Stop Frequencies For Channelized Measurements* on page 6-3.*

4. Specify the required statistics to be acquired by checking any or all of the following statistics type selection boxes:
 - Maximum Channelized Power
 - Average Channelized Power
 - Fixed Threshold Availability
 - Variable Threshold Availability
5. If Variable threshold Availability is selected then enter threshold increment in dB in the **Threshold Increment** dialog box. A typical value is 3 dB.
6. After verifying that the entered values and selections are correct, click on **Save**.
7. Repeat steps 2 through 6 to define additional statistical measurements and when finished click on OK to close the **Statistical Measurement Definition** dialog box.

***Note:** Statistical Measurements must be taken over a minimum time period of 5 minutes at the end of which time the data will be stored to the hard disk. (See Chapter 12 for a description on how to change the time interval.)*

Signal Masks

When performing Signal Logging or Occupancy measurements you may wish to exclude some portions of the spectrum from the monitoring process. This is accomplished by selecting and activating mask files that list the frequency bands that you wish to exclude from the monitoring process. Your system as delivered includes a sample demonstration signal mask. For detailed instructions on how to create signal masks for your specific monitoring application, see **Generation Of Mask Files** found in **Chapter 12, System Administration**.

Selecting And Activating A Mask

Signal masks are activated globally such that each measurement that calls for masking will have access to the single mask definition in effect. To select and activate a mask:

1. Click on **Setup** on the **Menu Bar** and from the **Signal Masking** select **Signal Masking** which gives you the option to select **Activate** or **Set New System Mask**.
2. Select **Set New System Mask...** to open the **Select System Mask** dialog box (Figure 6-25)

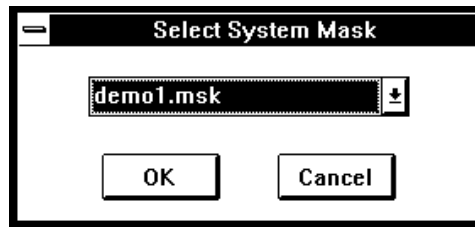

Figure 6-25: Select System Mask Dialog Box

3. Click on the **Arrow Button** box in the **Select System Mask** dialog box to open a menu listing all of the available Mask Files.
4. Select the desired Mask File and then click on **OK** which activates the selected mask file for all measurements calling for masking.

***Note:** You may disable the selected mask at any time by selecting **Inactive** from the **Signal Masking** options available from the **Setup** menu and reactivate the same mask by selecting **Active** by following the same menu path.*

5. If you would like to use a different mask file, repeat steps 1 through 4 and select a new mask file from the available Mask File list.

Invoking Masking For a Specific Measurement

An active mask file may be invoked by any measurement subject to masking by checking the Masking box in the corresponding signal measurement definition dialog box. Masking may be selected for occupancy measurements and Signal Logging measurements to exclude bands of signals from measurement.

Assembling Your Monitoring Plan

***Note:** In order to assemble and save a new Monitoring Plan you must have available to you previously defined and saved frequency band and measurement definitions that you wish to use in your Monitoring Plan.*

To assemble a Monitoring Plan:

1. Click on **S**etup in the **Main Menu Bar** and from the dropdown menu select **M**onitoring Plan... to open the **M**onitoring Plan Definition Dialog Box (Figure 6-26).

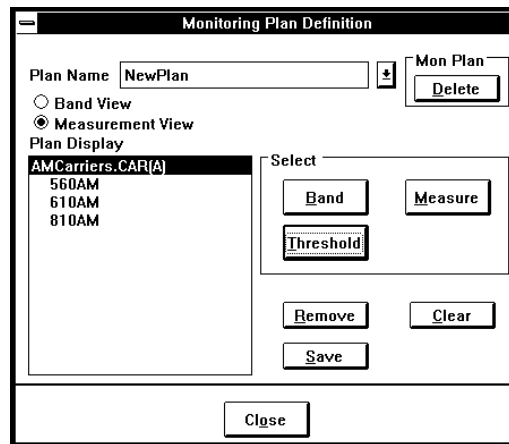

Figure 6-26: Monitoring Plan Definition Dialog Box

2. Enter a descriptive name in the **Plan Name** edit box.

***Note:** The Monitoring Plan Definition dialog box opens in a default **Measurement View** state, all Monitoring Plan definition is performed in this state. You may select Band View by clicking on the Band View radio button to display each band and the measurement performed on it. Band view is a display mode only.*

3. Click on **M**easure to open the **M**easurement Select Dialog Box (Figure 6-27).

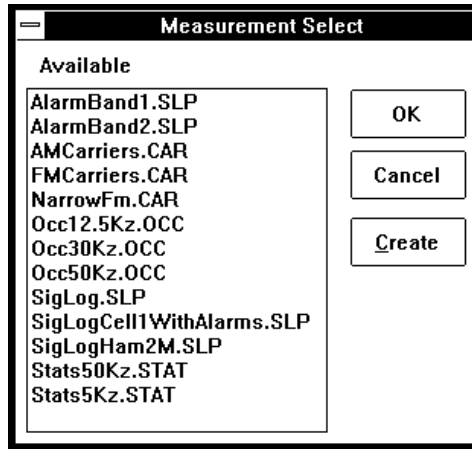

Figure 6-27: Measurement Select Dialog Box

4. Click and highlight the measurement(s) that you wish to include in your Monitoring Plan and click **OK**, which will enter them in the Monitoring Plan Definition **Plan Display**.
5. If a measurement that you need does not appear in the **Measurement Select** list then click on **C**reate to open the **Measurement Types** dialog box (Figure 6-28).

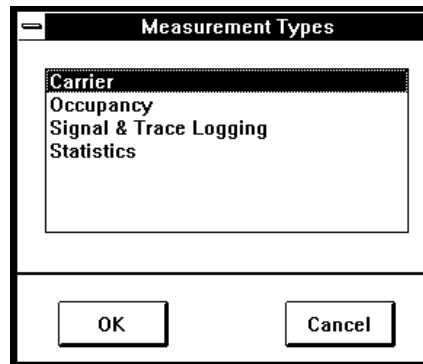

Figure 6-28: Measurement Types Dialog Box

6. Click on the measurement type that you wish to define and then **OK** to open the corresponding measurement definition dialog box. Complete the measurement definition as described in Defining Measurements on page 6-11, click on **S**ave and then **C**lose to return to the **Measurement Select** dialog box.

The newly defined measurement is now available for inclusion in the **Plan Display** as in step 4.

7. To attach a frequency band or bands to a measurement, click on a measurement listed in the **Plan Display** to highlight it and then click on **B**and to open the **Band Select** dialog box (Figure 6-29).

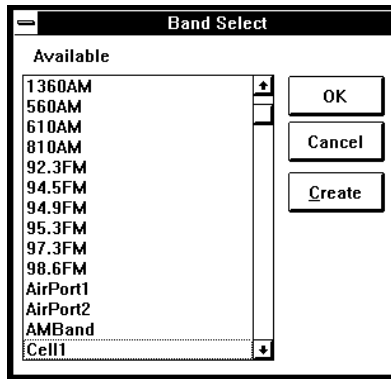

Figure 6-29: Band Select Dialog Box

8. Click and highlight the band or bands that you wish to associate with the selected measurement and click **OK** to close the **Band Select** Dialog Box and list the selected bands under the measurement in the **Plan Display** of the Monitoring Plan Definition dialog box.
9. If a band that you need does not appear in the **Band Select** list then click on **Create** to open the **Band Definition** dialog box.
10. Complete the measurement definition as described in the section **Defining Frequency Bands**, click on **Save** and then **Close** to return to the **Band Select** dialog box.
11. Include the newly defined frequency band in the **Plan Display** as in step 8.

Note: All the available measurement categories incorporate a default threshold selection when the measurement is included in a Monitoring Plan, which is identified by a threshold identifying character in the measurement identifier extension. The default thresholding categories are:

Carrier Measurements .CAR(A) "A" signifies Auto Threshold

Occupancy Measurements .OCC(A)

Signal Logging Measurements .SLP(A)

Statistical Measurements .STAT(F) "F" signifies Fixed Threshold

In all of the above measurement categories, except Statistical Measurements, you may select the thresholding from the three available choices of Auto (A), Fixed (F) or Profile (P). Statistical measurements permit only fixed thresholding (F) with a default threshold value of -80 dBm which you may change to suit your monitoring requirements.

"Fixed Threshold" is a user set power level which must be exceeded for a signal to be reported by the HP E4900. (The default margin above the threshold, for a signal to be reported, is that it must exceed the threshold by 6 dB. For example, if you set a threshold power level of -90 dBm, then a signal power level must be ≥ -84 dBm to be reported. A signal with a power level of -87 dBm will not be reported even though it exceeds the -90 dBm threshold, since it does not meet the default 6 dB margin requirement.)

"Auto Threshold" is a power level determined by the application program based on the average noise floor displayed on the spectrum analyzer trace. This threshold is updated each sweep to compensate for changes in the displayed noise level.

12. If you wish to change the default threshold assignment for a selected measurement then click on **T**hreshold to open the **Threshold Select** dialog box (Figure 6-30).

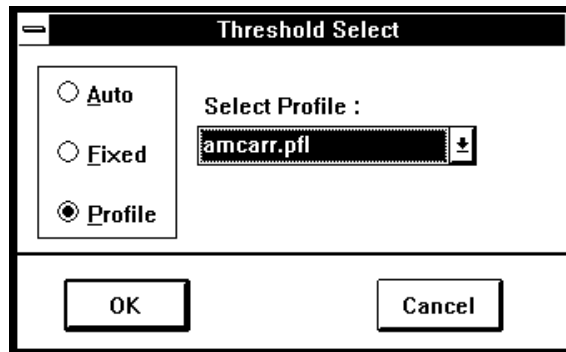

Figure 6-30: Threshold Select Dialog Box

13. Select the desired thresholding category that is permitted for your measurement, set the fixed threshold or select a profile as applicable and click **OK** to return to the **Monitoring Plan Definition** Dialog Box.
14. Click on **S**ave to save the newly defined Monitoring Plan and **C**lose, unless you wish to define another Monitoring Plan.

Running And Controlling Your Monitoring Plan

Once you have defined one or more Monitoring Plans, you may select and execute them manually at will, or you may schedule them for automatic execution at specific times and dates under a Monitoring Schedule.

Running Your Monitoring Plan Manually

To run your Monitoring Plan:

1. Click on **File** on the main Menu Bar to open the **File Menu** and then select **Open...** to open the **Enter Monitoring Plan** dialog box (Figure 7-1).

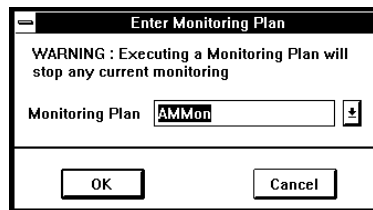

Figure 7-1: : Enter Monitoring Plan Dialog Box

2. Click on the **Arrow Button** to open the **Monitoring Plan** menu, listing all of the available pre-defined Monitoring Plans.
3. Select the desired Monitoring Plan for execution by highlighting its name in the **Monitoring Plan** menu and then click on **OK** to activate the selected Monitoring Plan.

After monitoring starts, the **Status Bar** (Figure 7-2) will reflect the status of the current Monitoring Plan in progress.

HP E4900 Series Spectrum Monitoring System (Opt 003)						
File	Setup	Reports	View	Control	Help	
11360AM	CF: 1.37 MHz	PWR: -34.53 dBm	S/N: 39.87 dB	OBSV: 4.24 kHz	SCHED: IDLE	
OCC: IDLE	CAR: ACTIVE	SLP: IDLE	STAT: IDLE	MSK: OFF	MONITORING: AMMon	

Figure 7-2: Monitoring Plan Status Bar Display

The bottom part of the **Status Bar** displays the type of measurement that is currently being performed by displaying the appropriate measurement box in Blue letters. In the event that a Monitoring Plan calls for more than one measurement type, the appropriate measurement box will indicate “Active” during the time that particular measurement is being performed.

Note: The Carrier measurement box employs a color coding scheme to indicate Normal, Alarm, and Inability to perform a measurement by displaying the letters in Blue, Red, and Yellow respectively.

The top part of the **Status Bar** is active only when **Carrier** measurements are performed. It displays the monitored **Signal Name**, **Center Frequency**, **Measured Power**, **Signal to Noise** ratio, and **Occupied Bandwidth**. Additionally it displays **Schedule Status**.

***Note:** Your system can execute only one Monitoring Plan at a time. Starting a new Monitoring Plan while a previously active Monitoring Plan is suspended, will terminate the suspended Monitoring Plan.*

At your option, you may alternately suspend and then resume the current Monitoring Plan, or you may stop the execution of the current Monitoring Plan.

To Suspend Monitoring:

Choose **File** from the **Main Menu Bar** and then **Suspend Monitoring**, which will suspend execution of the current Monitoring Plan.

To Resume Monitoring:

Choose **File** from the **Main Menu Bar** and then **Resume Monitoring**, which will reactivate the suspended Monitoring Plan.

To Stop Monitoring:

Choose **File** from the **Main Menu Bar** and then **Stop Monitoring**, which will stop the execution of the current Monitoring Plan.

***Caution:** When you intend to stop monitoring, be careful not to choose **File Exit** instead of **File** from the **Menu Bar**. **File Exit** is the command to exit from the SMS Application Program and return the system to the Windows File manager.*

***Note:** Running a Monitoring Plan does not automatically open a corresponding display. For example, executing a Carrier Measurement Monitoring Plan does not automatically display a Carrier Measurement Window. To open an appropriate display refer to the following section on Display Management.*

Display Management

Your Monitoring System offers you a choice in selecting the type of display to view the current active monitoring. You may elect to display all of the three possible display types simultaneously if there are three monitoring types active or just select an individual window display to match the monitoring being performed.

Note: The display of all three monitoring types is generally unlikely because it would require the inclusion of Carrier, Occupancy and Signal Logging measurements under one Monitoring Plan. This is not recommended because such operation would significantly reduce the time available for each measurement type.

To make the appropriate display choice for your current monitoring application, choose **View** from the **Main Menu Bar** to open the display options list (Figure 7-3) and select the display format required.

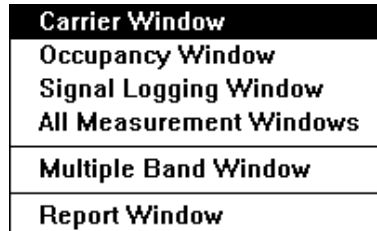

Figure 7-3: Display Options List

Figure 7-4 and Figure 7-5 are two representative display examples:

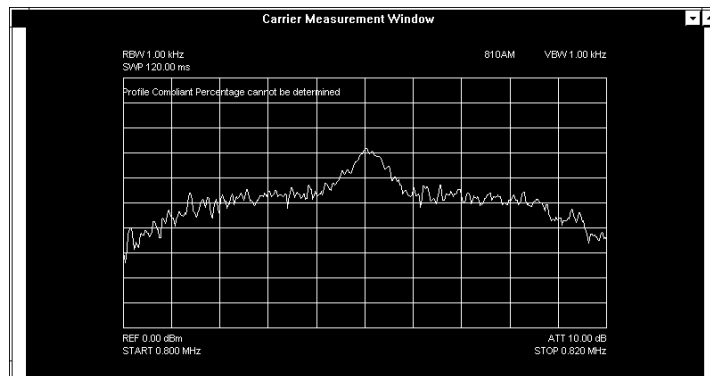

Figure 7-4: Typical Carrier Measurement Window Display

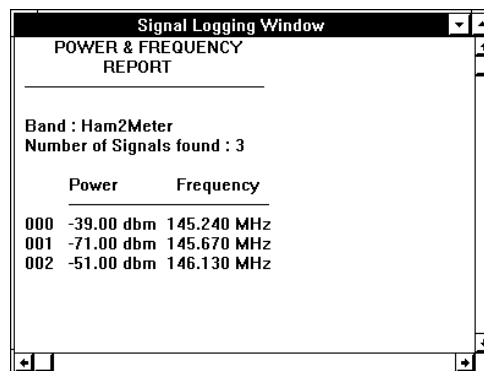

Figure 7-5: Typical Signal Logging Window Display

Setting Up And Running Your Monitoring Schedule

You may perform unattended monitoring by setting up a monitoring schedule to execute a Monitoring Plan or several Monitoring Plans on specific dates and times, and for specific time durations. A Monitoring Schedule is established by entering either, a Start and Stop Date and Time or a Start Date and Time and Time Span for each desired monitoring session defined in a Monitoring Plan.

To set up a Monitoring Schedule:

1. Click on **File** on the main Menu Bar to open the **File Menu** and then select **Schedule...** to open the **Monitoring Schedule Setup** dialog box (Figure 7-6).

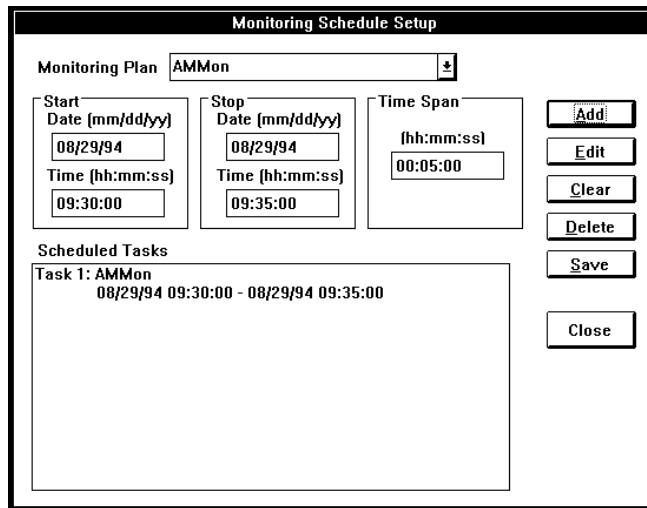

Figure 7-6: Monitoring Schedule Setup Dialog Box

2. Click on the **Arrow Button** box to open the **Plan Name** menu listing all the pre-defined Monitoring Plans in your system.
3. Highlight the Monitoring Plan to be scheduled and then enter either the Start Date (mm/dd/yy) and Time (hh:mm:ss) and Stop Date (mm/dd/yy) and Time (hh:mm:ss) or the Start Date (mm/dd/yy) and Time Span (hh:mm:ss).

Note: Time must be entered using a 24 hour format. For example 5:15PM would be entered as 17:15:00. There may be a delay of up to 10 seconds from the entered start time to the actual start time depending on what other monitoring program processes are active.

4. Verify that the entered values are correct and click on **Add** to enter the scheduled plan in the **Scheduled Tasks** window.
5. To schedule additional Monitoring Plans, repeat steps 2 through 4 .
6. After all of the required Monitoring Plans have been scheduled click on **Save** and then on **Close** to close the **Monitoring Schedule Setup** dialog box..

Note: Clicking on **Save** activates the Monitoring Schedule. The Status box will now indicate **SCHED: PENDING** or **SCHED: ACTIVE** depending on the Start Time of the first task.

Viewing the SA Window when a Schedule is Active or Pending

To view traces in the Spectrum Analyzer window, you must transfer control of the spectrum analyzer from programmed control under the scheduler to manual control using operator inputs. Do this by making the Scheduler inactive. When finished viewing the Spectrum Analyzer window, it is necessary to reactivate the scheduler manually.

To view the Spectrum Analyzer window:

1. Click on **Control** on the Main Menu bar and select **Spectrum Analyzer**.
2. Note the warning message that switching to the Spectrum Analyzer window will inactivate the Scheduler. If acceptable, (no scheduled tasks are close to starting), click on **OK**.
3. The Spectrum Analyzer window will be displayed. The SCHED status box will now display SCHED: INACTIVE in Red. All **Schedule** selections under **Setup** on the Main Menu bar are now grayed out.
4. When finished using the Spectrum Analyzer window select **Window**, then **Exit Spectrum Analyzer**.
5. At the end of working with the Spectrum Analyzer window, select **Setup**, then **Schedule** and then **Scheduled Task(s) Active** to re-activate the Scheduler (see Figure 7-7).

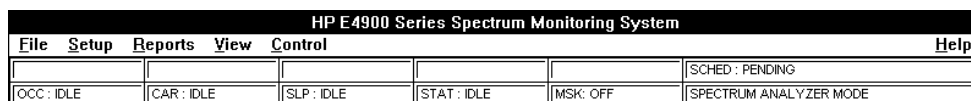

HP E4900 Series Spectrum Monitoring System					
File	Setup	Reports	View	Control	Help
					SCHED: PENDING
OCC: IDLE	CAR: IDLE	SLP: IDLE	STAT: IDLE	MSK: OFF	SPECTRUM ANALYZER MODE

Figure 7-7: Scheduled Task(s) Reactivated

Running a Monitoring Plan Manually while Scheduler is Active or Pending

To run a Monitoring Plan while the Scheduler is active, it is necessary first to deactivate the Scheduler. At the completion of manual monitoring, it is necessary for you to re-activate the Scheduler manually.

To run a Monitoring Plan when the Scheduler is Active or Pending.

1. Click on **File** and **Open**. Note the warning message that Executing a Monitoring Plan will inactivate the Scheduler and click **OK**.
2. Note the following Reminder message that you need to remember to Reactivate the Scheduler when you are through with manual monitoring! Click **OK**.
3. In the **Enter Monitoring Plan** window, select the desired monitoring plan and click on **OK**.

4. At the end of manual monitoring, select **Setup** then **Schedule** then **Scheduled Task(s) Active** to re-activate the Scheduler.

Viewing Multiple Band Windows when Scheduler is Active or Pending

It is not necessary to de-activate the Scheduler in order to operate in the Multiple Band Window.

***Note:** Using Multiple Band Windows while manual or scheduled monitoring is active will decrease the data acquisition rate because the Multiple Band Window data is taken in series with monitoring plan data. The program cannot collect data for both at the same time.*

Generating Reports

Each of the performed measurements generates one or more data files of data representing the measurement result. This data may be retrieved as Reports that can be displayed in alphanumeric or graphical form, depending on the type of measurement. In addition the data can be exported to spreadsheet programs such as Microsoft Excel and Quattro Pro.

Viewing Reports

Your program provides you with the capability to display a variety of reports: To select an available report for viewing click on **Reports** in the **Main Menu Bar** which opens the **Reports List** (Figure 8-1) showing all of the available report selection choices.

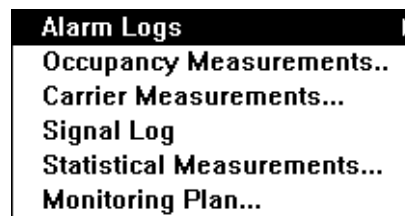

Figure 8-1: Available Report Type List

Click on the desired report type to open a dialog box to select the required report for display.

Note: It is not recommended to view reports while monitoring is in progress. (Doing so will slow the system down and may cause database conflicts).

Alarm Log Reports

Your Monitoring System Generates three types of Alarm Logs, provided that alarms are activated in the measurement definition, and that the specified alarm conditions have been met. Selecting **Alarm Logs** from the Available Report Type list offers you the choice of the Alarm Log to display (Figure 8-2).

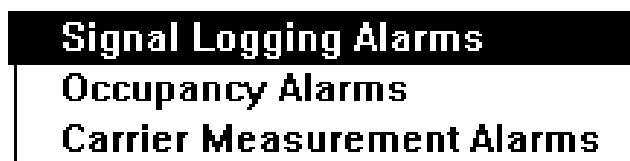

Figure 8-2: Available Alarm Report Types

Figure 8-3, Figure 8-4, and Figure 8-5 illustrate each of the available Alarm Log types.

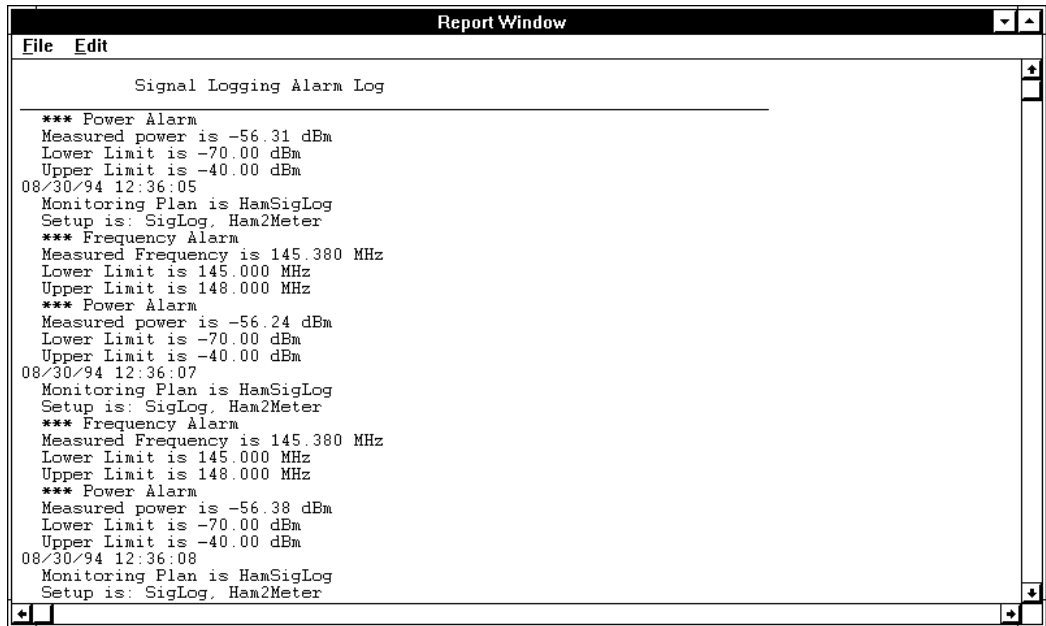

Figure 8-3: Typical Signal Logging Alarms Log

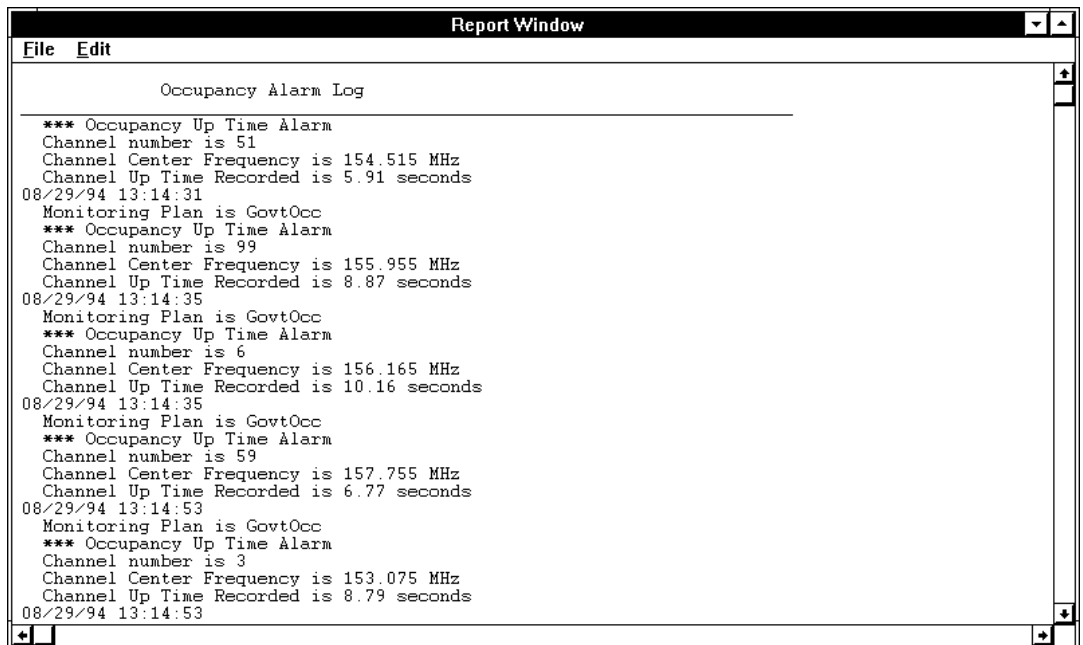

Figure 8-4: Typical Occupancy Alarms Log

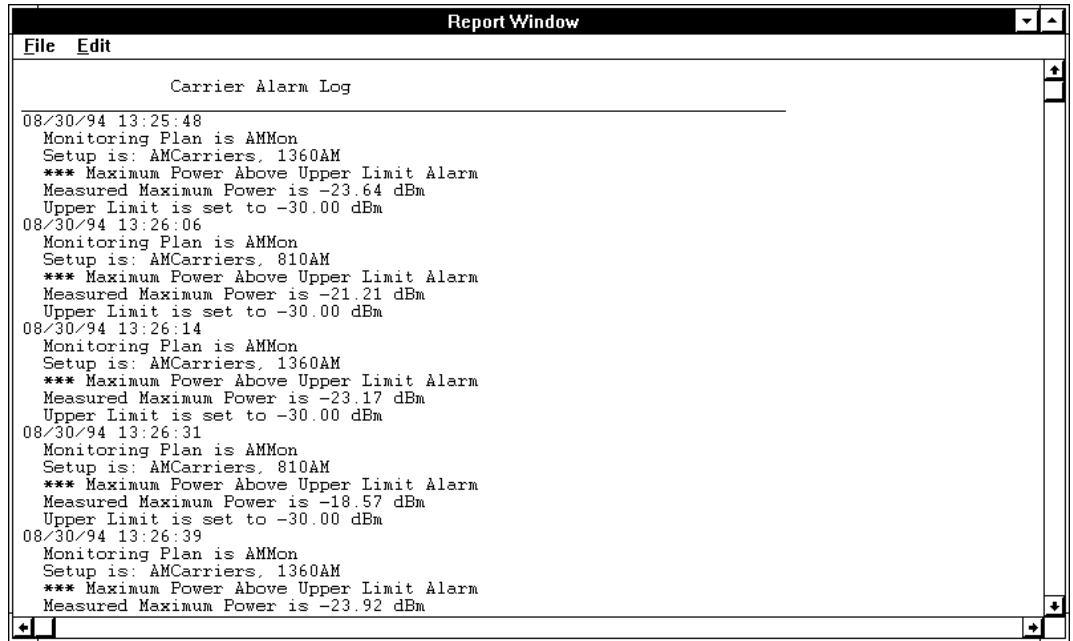

Figure 8-5: Typical Carrier Alarms Log

Occupancy Measurements Reports

Occupancy measurements reports permit you to view the results of Running Occupancy measurements by providing you the option to select any one of the following three types of graphical presentation:

- Running Occupancy displaying Percentage Occupancy by Channel during the measurement interval.
- Maximum Message Length by Channel during the measurement interval.
- Average Message Length by Channel during the measurement interval.

Note: To view **Interval Occupancy** Reports you must first export the data to a spreadsheet program such as Microsoft Excel and view the data as text reports.

Viewing Occupancy Reports

To view Occupancy Reports:

1. Select Occupancy Measurements from the Reports List to open the Occupancy Report dialog box (Figure 8-6).

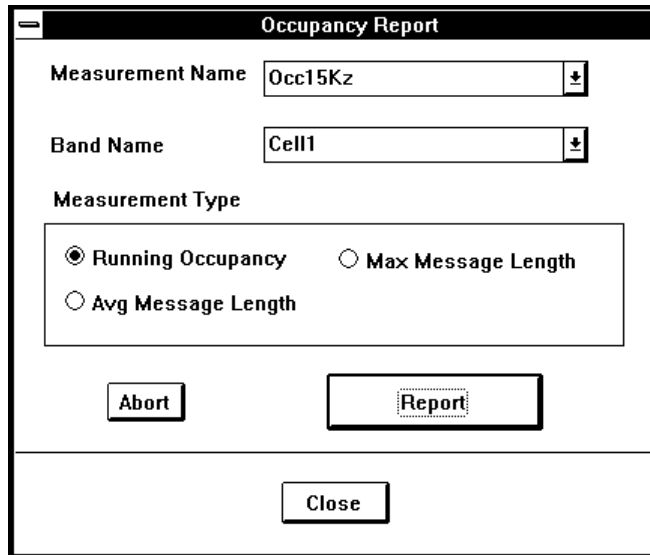

Figure 8-6: Occupancy Report Dialog Box

2. Click on the **Arrow Button** box associated with the **Measurement Name** to open the Measurement Name List.
3. Highlight the desired measurement to select it for association with a frequency band for display of an Occupancy Report.
4. Click on the **Arrow Button** box associated with the **Band Name** to open the Band Name List.
5. Highlight the desired band to select it for association with the selected measurement for display of an Occupancy Report.
6. Select the desired Measurement Type by clicking on the appropriate radio button in the **Measurement Type** selection box and then click on **OK**.
7. When you click **OK**, the **Occupancy Date/Time Selection** dialog box (Figure 8-7) will open.

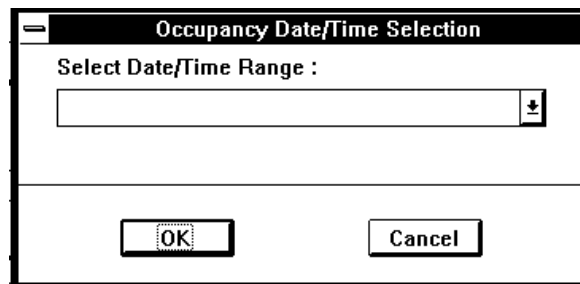

Figure 8-7: Occupancy Date/Time Selection Dialog Box

- Using the **Arrow Button**, choose from the list of date/time measurement events the date and interval that you want to view. By clicking on the event, the event parameters will appear in the **Select Date/Time Range** box (Figure 8-8).

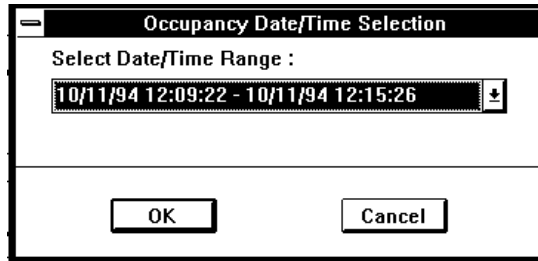

Figure 8-8: Filled Occupancy Date/Time Selection Dialog Box

- Click on **OK** to close the **Occupancy Date/Time Selection** dialog box and open the selected measurement type **Report Window** (Figure 8-9).

***Note:** The title on the Occupancy Report indicates the Occupancy Measurement Name and associated Band.*

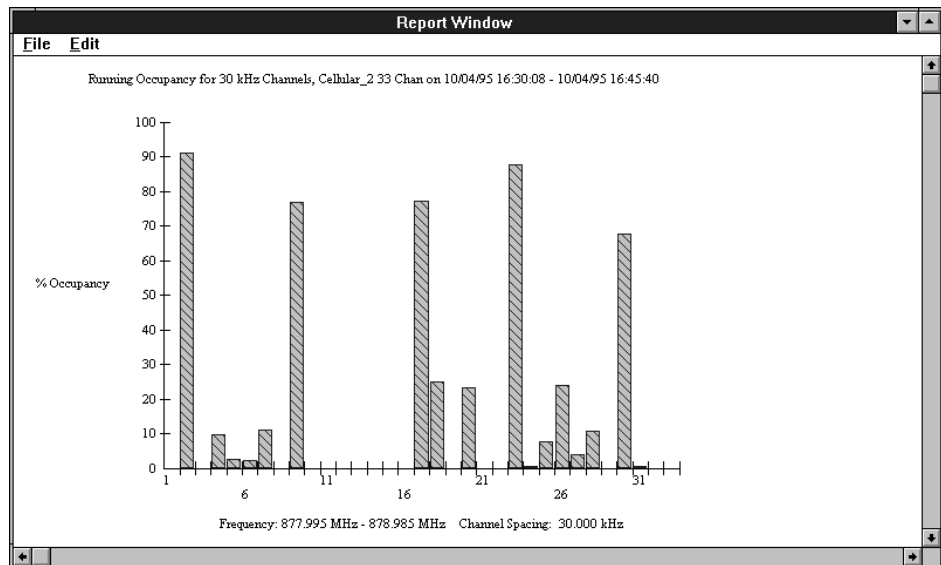

Figure 8-9: Typical Running Occupancy Report Display

Viewing Carrier Reports

To view Carrier Reports:

- Select **Carrier Measurements...** from the **Reports List** to open the **Carrier Report** dialog box (Figure 8-10)
- Click on the **Arrow Button** box to open the **Band Name** list.

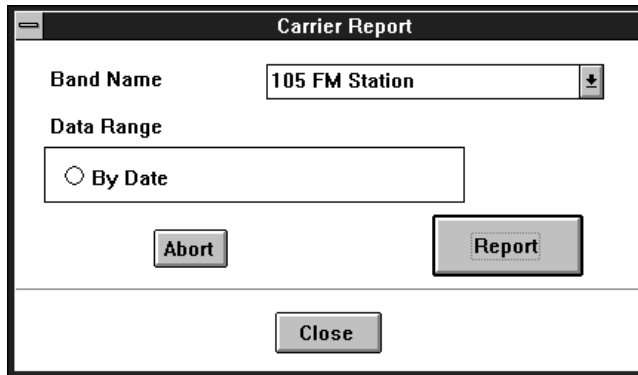

Figure 8-10: Carrier Report Dialog Box

4. Select the appropriate Band name
5. Optionally select By Date and enter the desired **Start Time**, **Start Date**, **Stop Time**, and **Stop Date** in the **By Date** (Figure 8-11) dialog box.

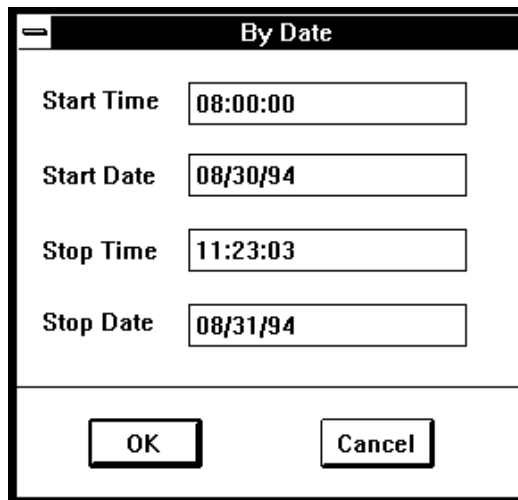

Figure 8-11: Typical By Date Dialog Box

***Note:** Time must be entered in 24 hour format.*

6. Click **OK** to return you to the **Carrier Report** dialog box.
7. Click on **Report** to open the Carrier Report Window (Figure 8-12).

Report Window							
Carrier Report - Band Name : 810AM							
08/30/94 - 08:00:00 to 08/31/94 - 11:23:03							
Freq MHz	Max Pwr	Avg Pwr	% AM	S/N	Occ BW	Profile Comp	
0.8101	-18.92	-32.72	-----	41.30	4.69	-----	
0.8101	-17.42	-31.71	-----	42.41	3.99	-----	
0.8102	-19.85	-32.83	-----	38.74	4.39	-----	
0.8102	-18.00	-32.00	-----	39.86	3.74	-----	
0.8102	-19.32	-32.12	-----	32.34	5.54	-----	
0.8101	-19.48	-32.21	-----	31.45	4.69	-----	
0.8101	-21.21	-33.24	-----	46.91	5.14	-----	
0.8101	-18.57	-32.40	-----	43.27	4.19	-----	
0.8100	-30.07	-42.81	-----	45.20	4.29	-----	100.00
0.8101	-27.85	-41.49	-----	47.28	5.94	-----	95.00
0.8101	-28.98	-42.42	-----	48.46	3.94	-----	97.50
0.8101	-28.10	-41.59	-----	47.52	4.24	-----	88.70
0.8101	-28.01	-41.17	-----	41.73	4.14	-----	97.70
0.8101	-28.92	-41.84	-----	39.82	4.34	-----	87.70
0.8101	-29.60	-42.45	-----	36.51	11.12	-----	83.20
0.8100	-28.35	-41.62	-----	46.03	4.29	-----	70.80

Figure 8-12: Typical Carrier Measurement Report

*Note: The **File** menu in the **Report Window** offers you the options to save the displayed report in a designated file, print it, or open a previously stored report for reference.*

Viewing Signal Log Reports

To view Signal Log Reports:

1. Select Signal Log from the Reports List to open the Frequency & Power Report dialog box (Figure 8-13).

Figure 8-13: Frequency & Power Dialog Box

2. Click on the **Arrow Button** to open the **Band Name** list.

3. Highlight the desired band to select it for generating a report. To view a complete report, click on **Report**, but to view a report for a specific time period, click the **By Date** select button to open the **By Date** dialog box.
4. Optionally select **By Date** and enter the desired **Start Time**, **Start Date**, **Stop Time** and **Stop Date** in the **By Date** dialog box
5. Click **OK** to return you to the **Frequency & Power** dialog box.
6. click on **Report** to open the **Signal Logging Report Window** (Figure 8-14).

Note: Time must be entered in 24 hour format.

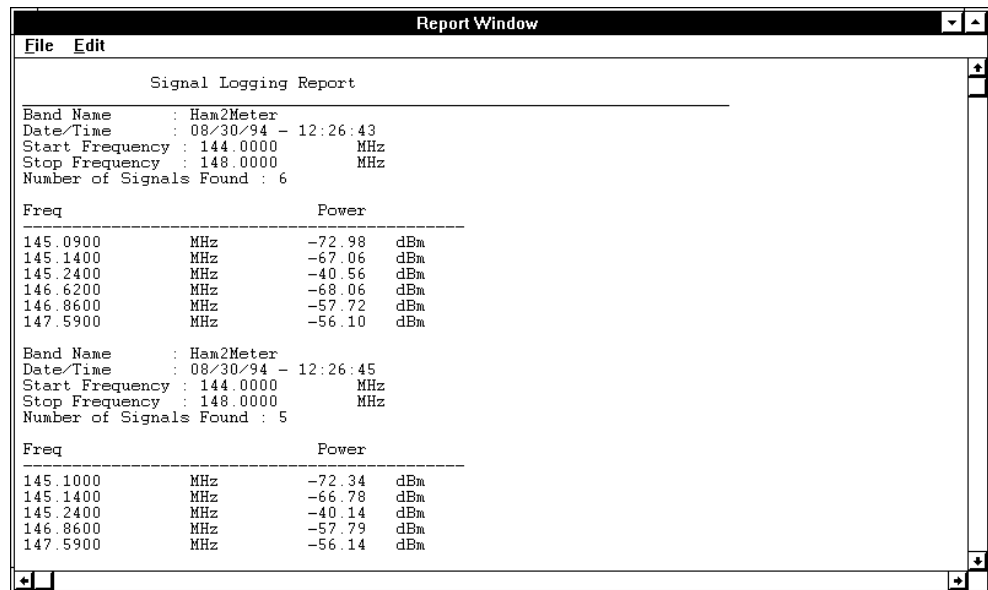

Figure 8-14: Typical Signal Logging Report

*Note: The **File** menu in the **Report Window** offers you the options to save the displayed report in a designated file, print it, or open a previously stored report for reference.*

Viewing Statistical Measurements Reports

Your system displays statistical measurement reports as graphics only, no text reports are generated for display. You may, however, export statistical data to a spreadsheet program such as Microsoft Excel to view the data in text format or to generate custom graphs. To view the graphical statistical measurement reports:

1. Select **Statistical Measurements...** from the **Reports List** to open the **Statistical Data Report** dialog box (Figure 8-15).

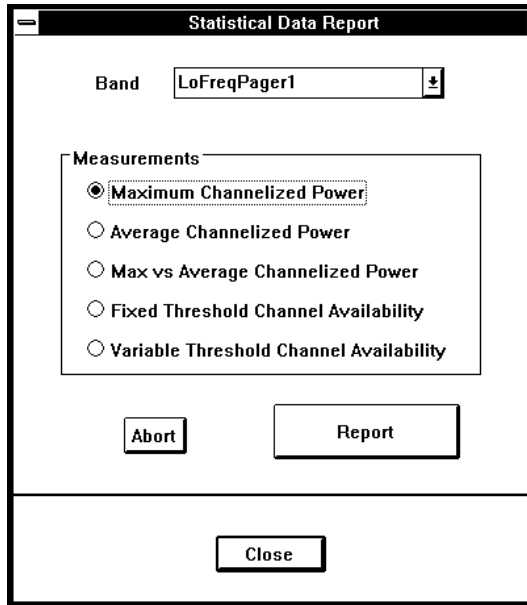

Figure 8-15: Statistical Data Dialog Box

2. Click on the **Arrow Button** box to open the **Band Name** list. Select the band for which you would like to generate a report and select the report type by clicking the appropriate **Measurements** radio button which will open the **By Date** dialog box.
3. Enter the desired **Start Time, Start Date, Stop Time and Stop Date** in the **By Date** dialog box and then click **OK** to return you to the **Statistical Data** dialog box and then click on **Report** to open the **Statistical Report Window**.

***Note:** Time must be entered in 24 hour format. The Variable Threshold Channel Availability report should be printed on a color printer to ensure easy viewing and analysis of the color-encoded graphics data.*

The following Figure 8-16 through Figure 8-21 illustrate how to request and then how some of the graphic statistical report measurement types appear on screen.

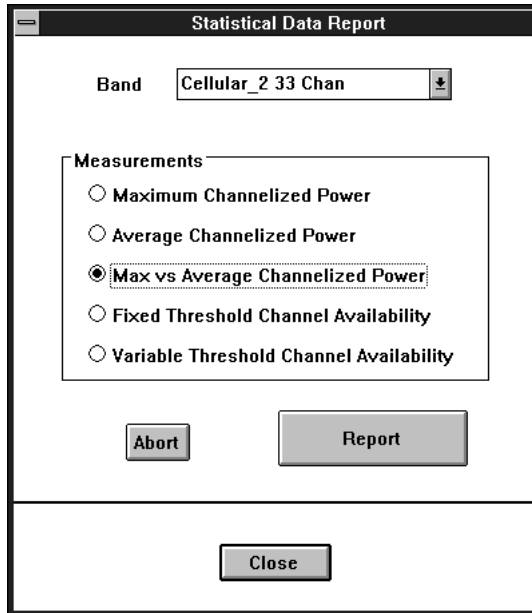

Figure 8-16: Requesting the Max vs Avg Channelized Power report.

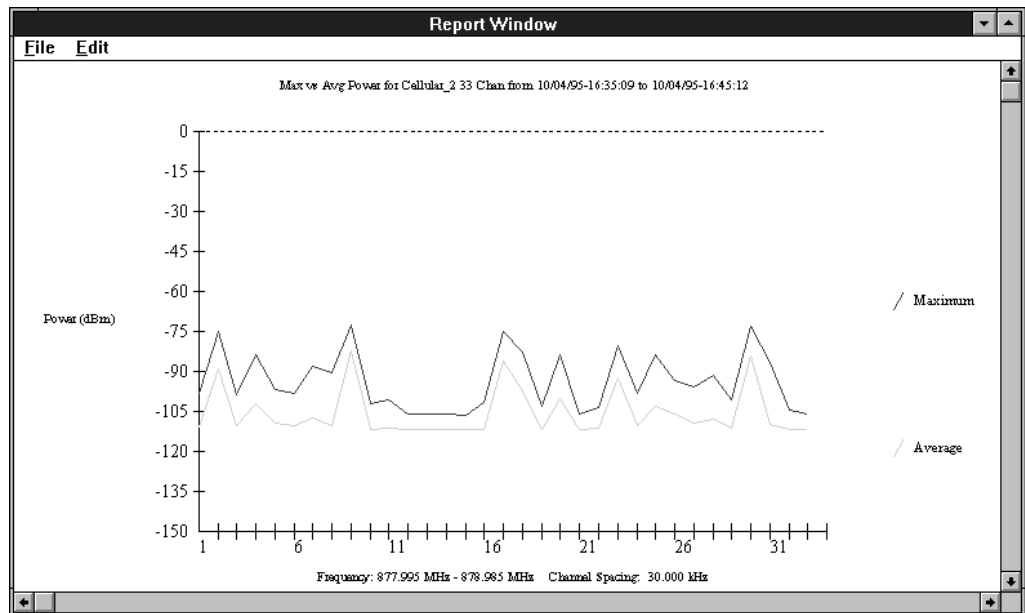

Figure 8-17: A Max vs. Avg Power Channelized Power report.

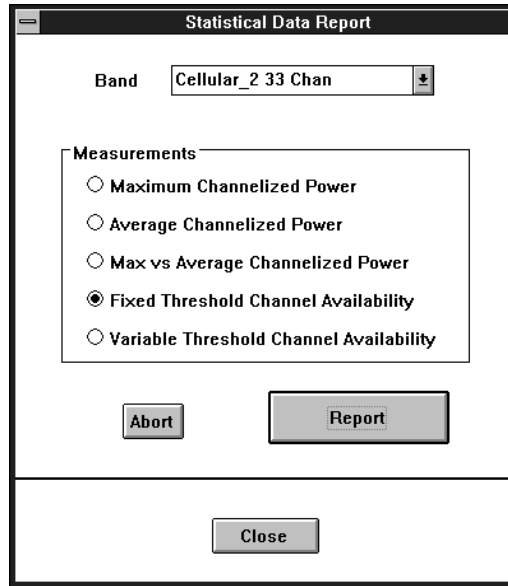

Figure 8-18: Requesting the Fixed Threshold Channel Availability report.

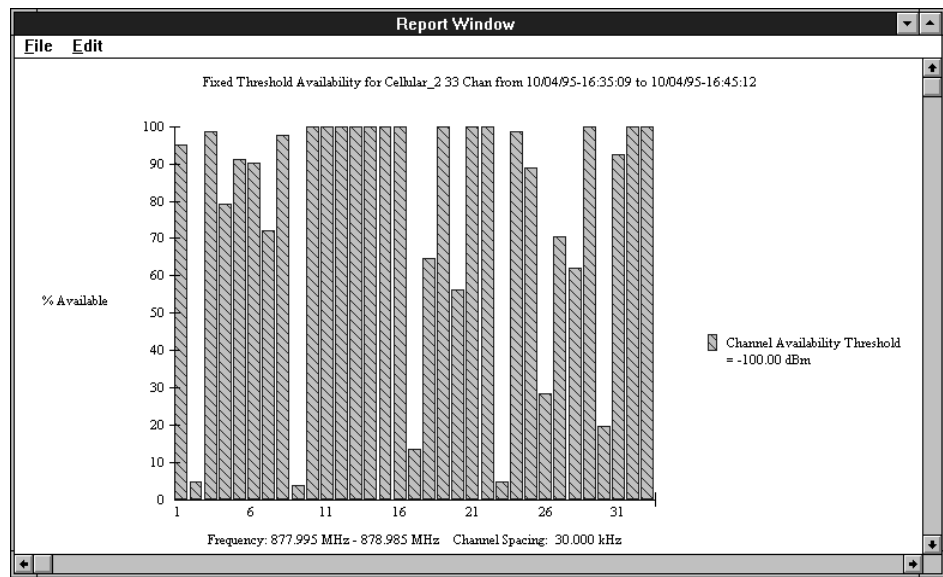

Figure 8-19: A Fixed Threshold Availability Plot.

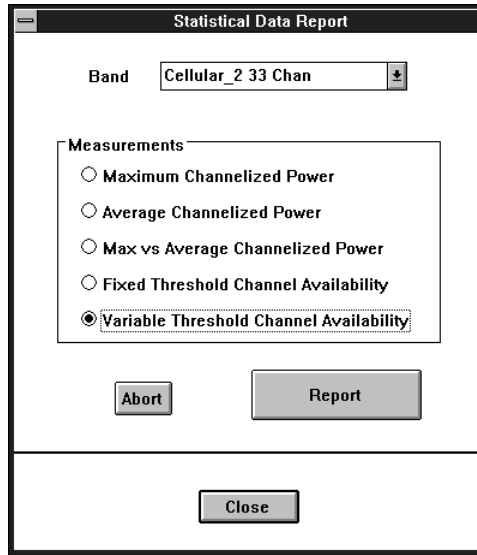

Figure 8-20: Requesting the Variable Threshold Channel Availability report.

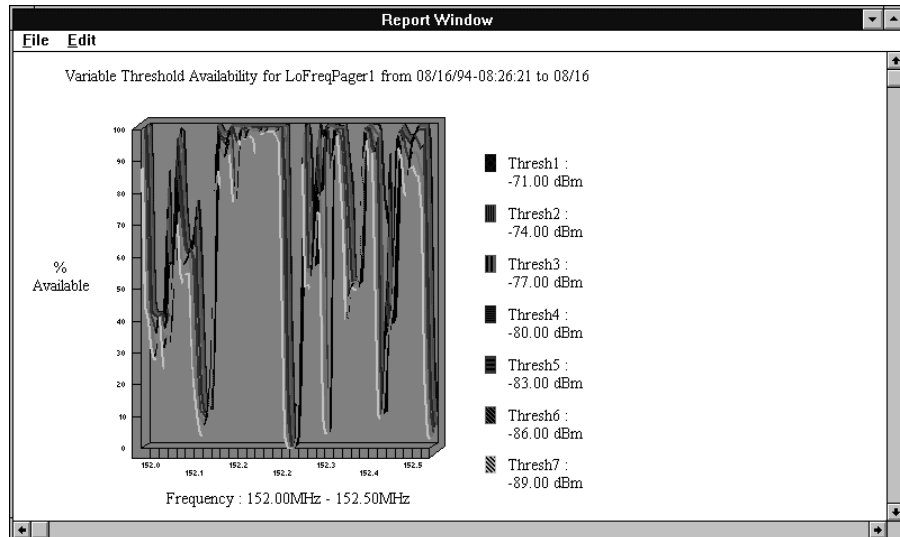

Figure 8-21: A Variable Threshold Availability plot

*Note: The **File** menu in the **Report Window** offers you the options to save the displayed report in a designated file, print it, or open a previously stored report for reference.*

Viewing Monitoring Plan Reports

A Monitoring Plan report summarizes the configuration of a Monitoring Plan by identifying the type of measurement performed, the bands monitored, and the thresholding employed. To view a Monitoring Plan:

1. Select **Monitoring Plan. . .** from the **Reports List** to open the **Monitoring Plan Report** dialog box (Figure 8-22).

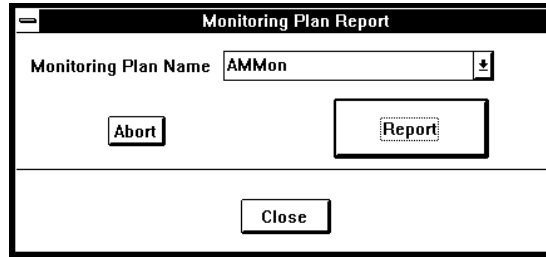

Figure 8-22: Monitoring Plan Report Dialog Box

2. Click on the **Arrow Button** box to open the **Monitoring Plan Name** list.
3. Highlight the desired **Monitoring Plan** to select it for generating a report. To generate and view a report, click on **Report** to open the **Monitoring Plan Report** window (Figure 8-23).

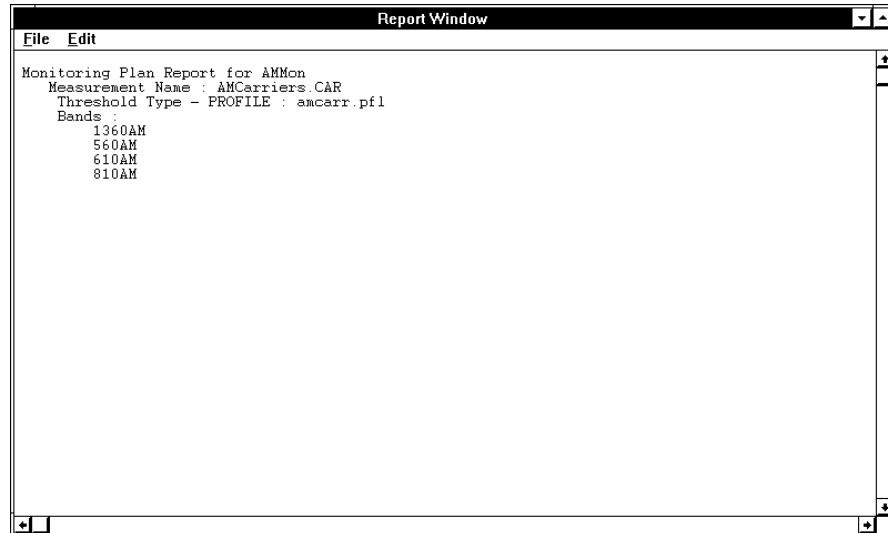

Figure 8-23: Typical Monitoring Plan Report

***Note:** The **File** menu in the **Report Window** offers you the options to save the displayed report in a designated file, print it, or open a previously stored report for reference.*

Viewing Saved Reports

You may recall for view any of the saved text or bit map reports at any time by clicking **View** on the Main Menu Bar and then **Report Window** to open the Report Window. To view a previously saved file, click on **File** in the Report Window, select **Open** and choose the type of file you wish to view (**Bitmap File...** or **Text File...**). This will open a standard Windows **Select File** dialog box permitting you to select and open a previously saved report.

Note: In addition to the text files that you have previously saved, your monitoring system saves the last text report viewed in temporary files that you may recall from the Report Window. These files are:

<i>cartmp.txt</i>	<i>Storing the last Carrier Report viewed</i>
<i>mptmp.txt</i>	<i>Storing the last Monitoring Plan Report viewed</i>
<i>sigtmp.txt</i>	<i>Storing the last Signal Logging Report viewed</i>
<i>occtmp.txt</i>	<i>Storing the last Occupancy Report viewed.</i>

Managing Disk Space

Data can be stored in a variety of formats: actual spectrum analyzer traces, signal lists (power, frequency pairs), occupancy, statistics, and carrier measurements. Traces and signals can consume disk space quickly, but occupancy, statistics, and carrier measurements are very economical with disk space.

Each set of signals or traces consumes 3.2-K. At the maximum data collection rate of 3 traces per second, the 440-MB free disk space on the standard systems can be consumed in 12 hours. It is pretty easy to come to the conclusion that the system does not have adequate information storage capacity. This calculation, however, was performed using worst case numbers—collecting data at the maximum speed and storing it in the least efficient format—and these numbers are not typical of real applications. You can do three things to improve the situation:

1. Reduce the data collection rate by increasing sweep speeds or by using multiple bands.
2. Use alarms to save only traces that exceed user-defined thresholds. 125,000 traces is a great amount of data, more than you probably have time to analyze. It may be better to only save the unusual traces on alarm. If alarm conditions are exceeded 5% of the time, for example, the disk will last for 10 days or more than one week.
3. Measure occupancy or statistics or carriers instead of signals and traces. signals and traces take up much more disk space than occupancy, statistics, and carrier measurements.

Archiving Reports

As you generate reports, run monitoring plans (Chapters 6 and 7), and as the system logs traces to the data base that are the result of alarm actions (Viewing Archived Traces, Chapter 5), the system stores data in the FMSDBS directory. All these reports are generated from data to this directory. As the data accumulates, generating reports will take longer.

If you do not actively use previously taken data, you can use the HP E4900 File Utilities program to archive data to the ARCHIVE directory. To do so see **Chapter 10: HP E4900 Database File Movement Utilities**.

Exporting Data

Your Monitoring System incorporates the capability to export system configuration and report data for viewing and reformatting by spreadsheet programs such as Microsoft Excel or Quattro Pro. Microsoft Excel can open Tab Delimited files and Comma Delimited files. Quattro Pro can import only Comma delimited files.

To export data:

1. Click on **F**ile on the main Menu Bar to open the **File Menu** and then select **Export Data** to open the Export Data selection list (Figure 9-1).

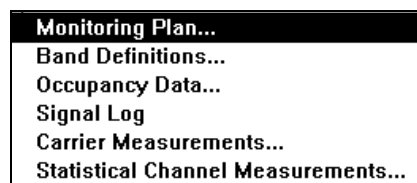

Figure 9-1: Export Data Selection List

Exporting Monitoring Plans

To export a Monitoring Plan or Plans:

1. Select **Monitoring Plan...** from the Export Data selection list to open the **Monitoring Plan Data Export** dialog box (Figure 9-2).

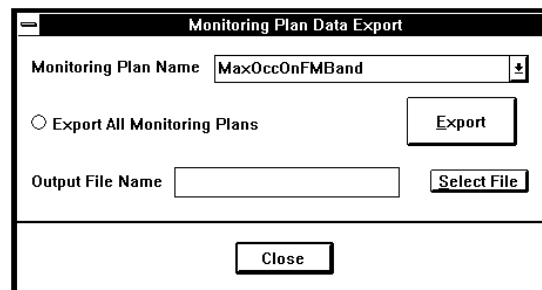

Figure 9-2: Monitoring Plan Data Export Dialog Box

2. Click on the Arrow Button to open the Monitoring Plan Name list or alternatively click on Export All Monitoring Plans.
3. Select a Monitoring Plan or enter a filename (the default directory is \sigmon\data) for export and then click on **Select File** to open the **Select File** dialog box (Figure 9-3).

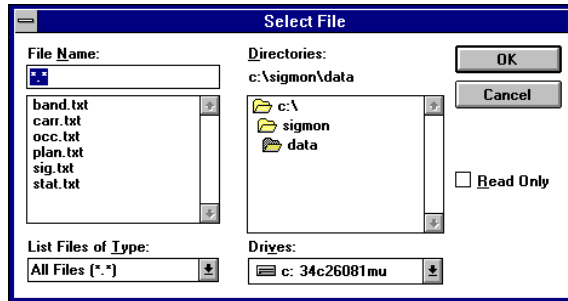

Figure 9-3: Select File Dialog Box

4. Enter a descriptive file name and destination and then click **OK** to return to the **Monitoring Plan Data Export** dialog box.

***Note:** File names must conform to standard DOS naming convention, that is, eight characters; no spaces; numbers and letters only; and so on.*

1. Click **Export** and, after a successful data transfer, **Close** to complete the export process.

Exporting Band Definitions

Exporting Band Definitions is procedurally identical to exporting Monitoring Plans. To export Band definitions you select **Band Definitions...** and enter data in the **Band Data Export** dialog box.

Exporting Occupancy Data

To export Occupancy Data:

1. Select **Occupancy Data...** from the Export Data selection list to open the **Occupancy Data Export** dialog box (Figure 9-4).

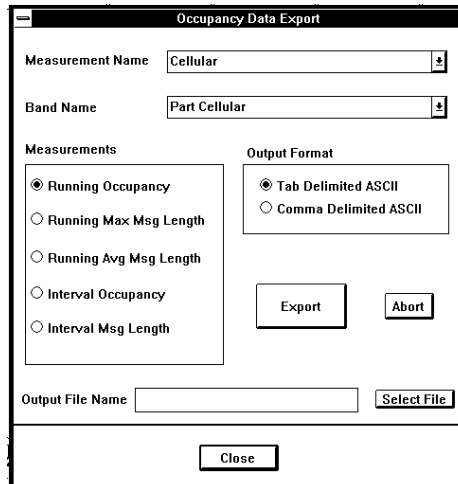

Figure 9-4: Occupancy Data Export Dialog Box

2. Click on the **Arrow Button** next to the Measurement Name box to open the **Measurement Name** list, select a measurement and then similarly, select a Band from the **Band Name** list.
3. Select the type of data by clicking the appropriate radio button in the **Measurements** section.
4. Select either Tab Delimited ASCII for Excel or Comma Delimited ASCII for QuattroPro by clicking on the appropriate radio button in the **Output Format** section.
5. Enter a filename(the default directory is \sigmon\data) in the Output File Name text box or click on **Select File** to open the **Select File** dialog box.
6. Enter a descriptive file name and destination and then click **OK** to return to the **Occupancy Data Export** dialog box.
7. Click **Export** and, after a successful data transfer, **Close** to complete the export process.

Exporting Signal Log Data

To export Signal Log Data:

1. Select **Signal Log** from the Export Data selection list to open the **Frequency & Power Data Conversion** dialog box (Figure 9-5).

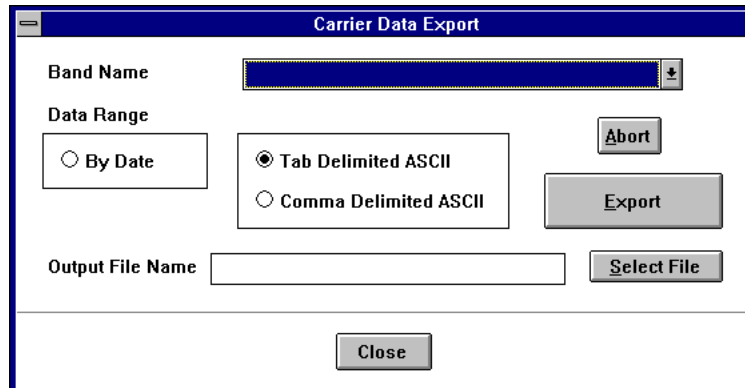

Figure 9-5: Frequency & Power Data Export Dialog Box

2. Click on the **Arrow Button** next to the Band Name box to open the **Band Name** list.
3. Select a **Measurement** for export and if you would like the data to be limited to a specific time span. Click on the **By Date** radio button and enter the required date and time span in the **By Date** dialog box.
4. Select either Tab Delimited ASCII for Excel or Comma Delimited ASCII for QuattroPro by clicking on the appropriate radio button in the **Output Format** section.
5. If you would like the data to be limited to a specific time span then click on **By Date** in the Data Range box and enter the required date and time span in the **By Date** dialog box.
6. Enter a filename (the default directory is \sigmon\data) in the Output File Name text box or click on **Select File** to open the **Select File** dialog box.
7. Enter a descriptive file name and destination and then click OK to return to the **Frequency & Power Data Conversion** dialog box.
8. Click **Export**. After a successful data transfer, click **Close** to complete the export process.

Exporting Carrier Measurement Data

To export Carrier Measurement Data:

1. Select **Carrier Measurements...** from the Export Data selection list to open the **Carrier Data Export** dialog box (Figure 9-6).

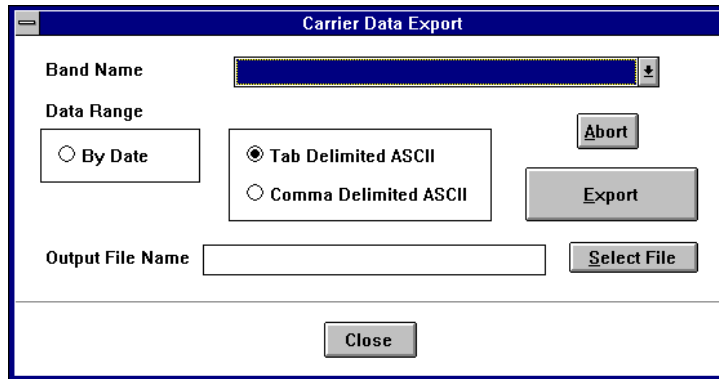

Figure 9-6: Carrier Data Export Dialog Box

2. Click on the **Arrow Button** next to the Band Name box to open the **Band Name** list.
3. Select a **Measurement** for export. If you would like the data to be limited to a specific time span, click on the **By Date** radio button and enter the required date and time span in the **By Date** dialog box.
4. Select either Tab Delimited ASCII for Excel or Comma Delimited ASCII for QuattroPro by clicking on the appropriate radio button.
5. If you would like the data to be limited to a specific time span then click on **By Date** in the Data Range box and enter the required date and time span in the **By Date** dialog box.
6. Enter a filename(the default directory is \sigmon\data) in the Output File Name text box or click on **Select File** to open the **Select File** dialog box.
7. Enter a descriptive file name and destination and then click **OK** to return to the **Carrier Data Export** dialog box.
8. Click **Export**. After a successful data transfer, click **Close** to complete the export process.

Exporting Statistical Measurement Data

To export Statistical Measurement Data:

1. Select **Statistical Channel Measurements...** from the Export Data selection list to open the **Statistical Data Export** dialog box (Figure 9-7).

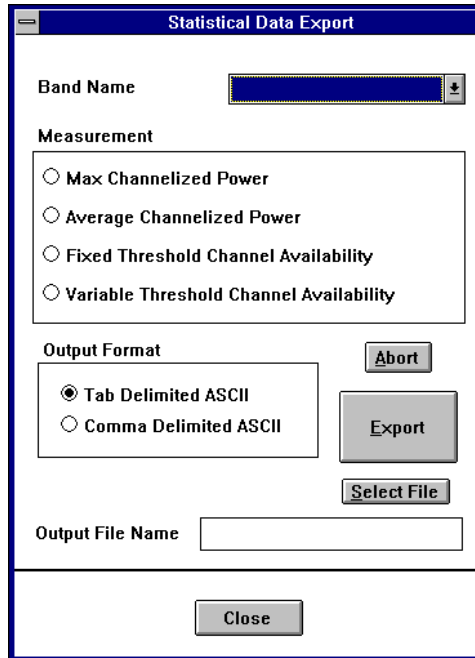

Figure 9-7: Statistical Data Export Dialog Box

2. Click on the **Arrow Button** next to the Band Name box to open the **Band Name** list.
3. Select a **Band** for export and then select a measurement type by clicking the appropriate radio button in the **Measurement** box which will open the **By Date** dialog box.
4. Enter your required date and time span in the **By Date** dialog box and click **OK**.

***Note:** You may accept the total time span shown as default without entering new time and date values by clicking **OK** immediately.*

5. Select either Tab Delimited ASCII or Comma Delimited ASCII by clicking on the appropriate radio button in the **Output Format** section.
6. Enter a filename(the default directory is \sigmon\data) in the Output File Name text box or click on **Select File** to open the **Select File** dialog box.
7. Enter a descriptive file name and destination and then click **OK** to return to the **Statistical Data Export** dialog box.
8. Click **Export**. After a successful data transfer, click **Close** to complete the export process.

Viewing Exported Data In A Spreadsheet Program

You may view exported data files off line by opening them in a spreadsheet program such as Microsoft Excel. Figure 9-8 is an example of an exported statistical data file as opened for viewing in Microsoft Excel.

Variable Threshold Statistics for Band : LoFreqPager1									
During the Period : 08/16/94 - 08:26:21 to 08/16/94 - 08:31:22									
Frequency Range : 152.00 MHz to 152.50 MHz									
Number of Channels Measured : 101									
Nominal Threshold = -80.00 dBm									
Threshold Increment = 3.00 dB									
Threshold = -71.00 dBm									
Date	Time	152	152.005	152.01	152.015	152.02	152.025	152.03	
8/16/94	8:26:21	100	100	45.21	41.1	41.1	41.1	45.21	
8/16/94	8:31:22	100	100	64.23	59.85	59.85	59.85	61.31	
Threshold = -74.00 dBm									
8/16/94	8:26:21	100	99.32	44.52	41.1	41.1	41.1	41.78	
8/16/94	8:31:22	100	100	62.77	59.85	59.85	59.85	60.58	
Threshold = -77.00 dBm									
8/16/94	8:26:21	100	93.84	44.52	41.1	41.1	41.1	41.1	
8/16/94	8:31:22	100	91.24	62.04	59.85	59.85	59.85	59.85	
Threshold = -80.00 dBm									
8/16/94	8:26:21	100	90.41	42.47	41.1	40.41	41.1	41.1	
8/16/94	8:31:22	100	89.05	60.58	59.85	58.39	59.85	59.85	
Threshold = -83.00 dBm									
8/16/94	8:26:21	99.32	69.86	41.1	39.73	35.62	41.1	41.1	
8/16/94	8:31:22	100	72.99	59.85	59.85	52.55	59.12	59.12	

Figure 9-8: Example of an Exported Statistical Data File

HP E4900 File Utilities

Your Monitoring System provides you with a set of off line utilities to backup and restore system setup configurations and to perform archiving of measurement results. To use the **Files Utilities** make sure that the HP 4900E Monitoring System is shut down and then click on **File Utilities** in the HP E4900 Window (Figure 10-1).

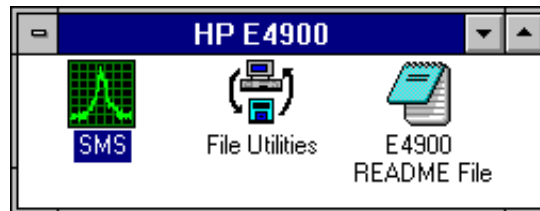

Figure 10-1: HP 4900 Control Window

This opens the **HP E4900 File Utilities** Window offering you the choice of operating on Setup or Data.

Performing Setup Backup and Restoration

To **Backup** the current system configuration:

1. Click **Setup** on the HP E4900 File Utilities Window Menu Bar and then select **Copy to Floppy** from the dropdown menu to open the **Copy Setups** Dialog Box (Figure 10-2).

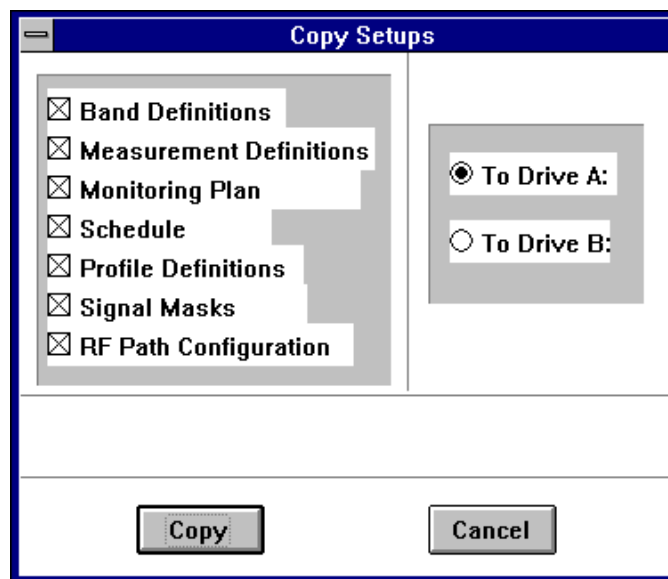

Figure 10-2: The Copy Setups Dialog Box

2. Insert an appropriately labeled, formatted diskette in a floppy disk drive slot, select any or all of the system configuration options to be backed up, check the appropriate **To Drive...** radio button and then **Backup**. The **File** window will confirm the files being backed up.

To **Restore** the system configuration:

1. Click **Setup** on the HP E4900 File Utilities Window Menu Bar and then select **Load from Floppy** from the dropdown menu to open the **Restore Setup** Dialog Box (Figure 10-3).

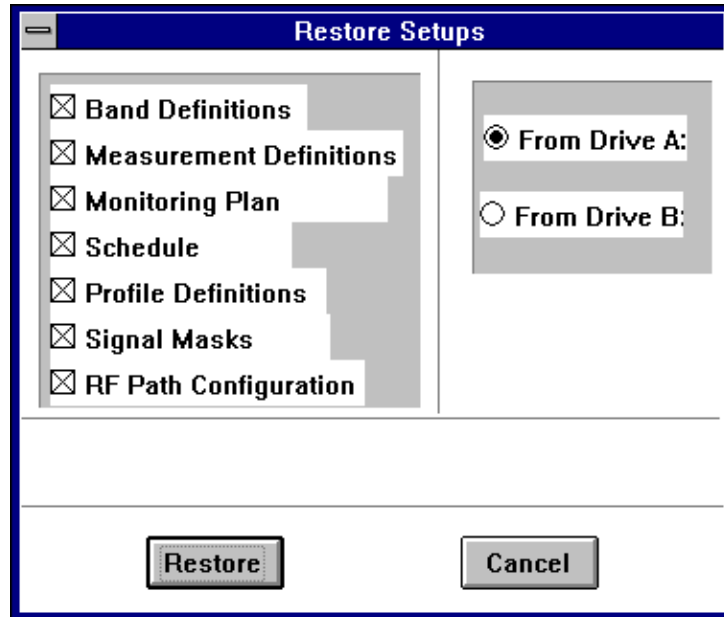

Figure 10-3: The Restore Setup Dialog Box

2. Insert the backup disk in an available floppy disk drive slot, select any or all of the system configuration options to be restored, check the appropriate **From Drive..** radio button and then **Restore**. The **File** window will confirm the files being restored.

***Note:** Restore Setup will overwrite any setup file chosen for restoration. Rename any setup file version you wish to save.*

Archiving And Restoring Archived Data

As you generate reports, run monitoring plans (Chapters 6 and 7), and as the system logs traces to the data base that are the result of alarm actions (Viewing Archived Traces, Chapter 5), the system stores data in the FMSDBS directory. All reports are generated from data in this directory. As the data accumulates, generating reports will take longer.

If you do not actively use previously taken data, you can use the HP E4900 File Utilities program to archive data to the ARCHIVE directory.

To **Archive** data to hard disk:

1. Click **Data** on the File Utilities window menu bar and then select **Archive Data to Hard Disk** from the dropdown menu to open the **Archive Data to Hard Disk** Dialog Box (Figure 10-4).

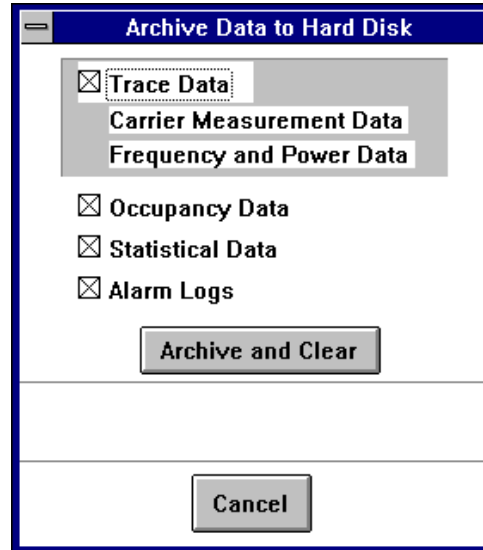

Figure 10-4: The Archive a Data to Hard Disk Dialog Box

2. Select any or all of the data categories to be archived and click on **Archive and Clear**. The **File** window will confirm the files being archived.

***Note:** The selected data files are compressed and archived while the original data source files are cleared.*

***Note:** You cannot be running HP E4900 SMS while archiving.*

When you archive data you are not freeing disk space. If you need more disk space you can copy the ARCHIVE directory to another media and then delete all the files in the ARCHIVE directory. When you use the Archive Data to Hard Disk utility, all previously archived data will be overwritten.

This process would be most useful to follow on a regularly scheduled basis. Typically you could, as the system administrator, weekly archive data, copy the ARCHIVE directory to a separate drive such as a tape drive designed for backup, and delete the contents of the ARCHIVE directory.

To Restore Data from Hard Disk:

1. Click **Data** on the File Utilities window menu bar and then select **Restore Data from Hard Disk** from the dropdown menu to open the **Restore Data from Hard Disk** Dialog Box (Figure 10-5).

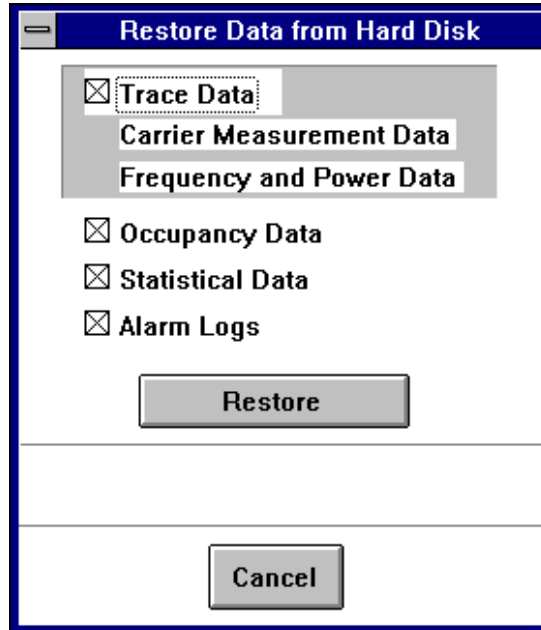

Figure 10-5: The Restore Data from Hard Disk Dialog Box

2. Select any or all of the data categories to be restored and click on **Restore**. The **File** window will confirm the files being archived.

Note: *Restore Data from Hard Disk will overwrite any data file chosen for restoration. Rename any data file version you wish to save.*

Using Your SMS Remote Software

You can control your SMS site remotely using the Carbon Copy[®] software shipped with your SMS computer. With this software you can perform any task from a central location that you could do on-site.

Starting Your Remote Software

Hewlett-Packard has installed Carbon Copy on both your on-site computer, which for our purposes is the Remote site, and on your controlling computer, which for our purpose is the Central site. The Central site is capable of controlling several Remote sites (see Figure 11-1).

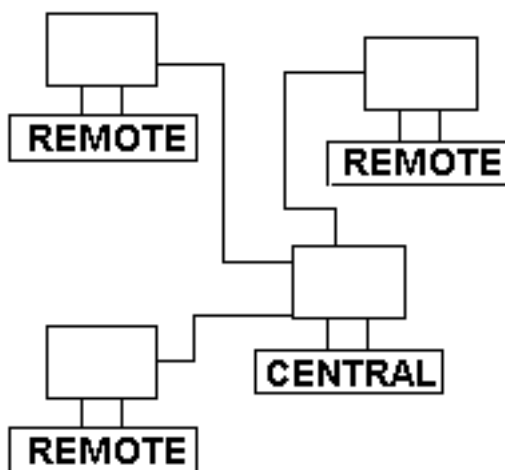

Figure 11-1: A Central site can control several Remote sites.



Both the remote and central locations have the complete Carbon Copy program installed so that you can use any site to control any other site. This manual assumes you are controlling remote sites, which are E4900 Systems, from a central location.

The Central location loads the Guest program of the Carbon Copy software. It will be a guest at the remote site computer and able to let you perform any task as if you were physically present at the site. The Remote locations load the Host program of the Carbon Copy software. You must start the Host program while physically present at the remote site or your System Administrator must have already prepared the Remote site's system to load this software and the SMS programs upon startup (see Chapter 6, System Administration) before you can access it from the Central location.

Starting Carbon Copy

To start the Carbon Copy program:

1. In Program Manager, locate the Carbon Copy program group.
2. Double-click on

- a. For a Remote site, the Host icon 
- b. For a Central site, the Guest icon 

Carbon Copy will load the appropriate interface (see Figure 11-2 and Figure 11-3).

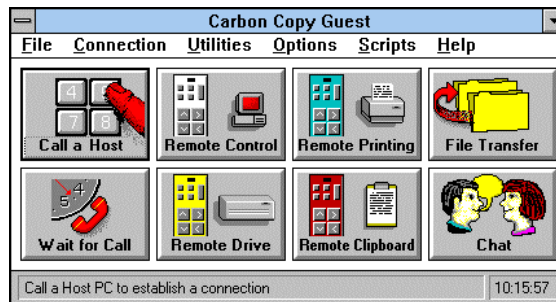

Figure 11-2: The Carbon Copy Guest window.

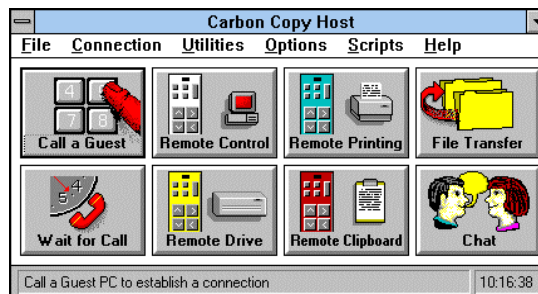

Figure 11-3: The Carbon Copy Host window.

By default, Hewlett-Packard has configured the remote site to open in its Waiting for Call mode and will load showing only the Waiting for Call icon on the Windows desktop (see Figure 11-4).



Figure 11-4: The Waiting for Call icon.

Setting the Waiting for Call Option

If you have not configured your Remote site to load in the Waiting for Call mode, you must configure it as such. To do so:

1. In the Carbon Copy Host window, select the Options menu.
2. Choose the Wait for Call on Startup option. It should have a check mark next to it if it is active.
3. Iconized the Carbon Copy Host window.

Carbon Copy Host will remain in the Wait for Call iconized state until called by a Guest/Central site. After disconnecting from the Central site, the Remote/Host software will return to the Wait for Call iconized state and will be ready to answer another call.

Checking and Setting Host Communications Options

The computer shipped with the E4900 does not come with a modem, so you must configure Carbon Copy to use your modem. (H-P does sell a modem that works well with the E4900 and Carbon Copy.)

To check the modem settings and correct them if necessary:

1. Select the Options menu in either the Host or Guest main menu.
2. Choose the Communications command.

Carbon Copy will present the Communications dialog box (see Figure 11-5).

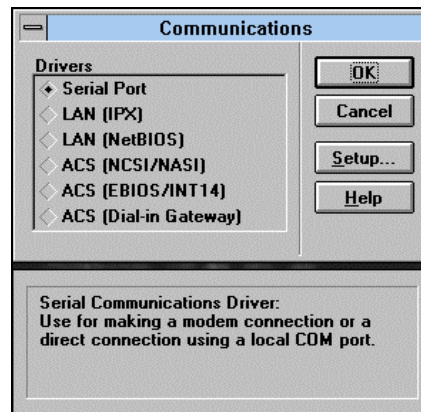

Figure 11-5: The Communications dialog box.

3. In the Drivers list box check that the Serial Port driver is selected. If not, click on Serial Port in the list. Its radio button should be filled in.

4. Click on the Setup button.

Carbon Copy presents the Serial Port Setup dialog box (see Figure 11-6).

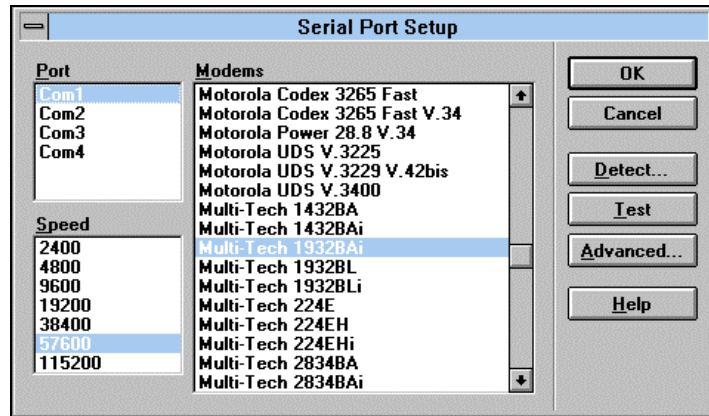

Figure 11-6: The Serial Port Setup dialog box.

5. Click on the Detect button. Carbon Copy will run its Detect Wizard and configure itself to use your modem.
6. In the Port list, Check that the Port is set to **E 001** COM1 or **003** COM3. If not, click on the appropriate entry.
7. In the Modems list, check that the modem selected matches the modem you have installed.
8. Check that the speed setting is set for 57600 bps and if it is not, click on the 57600 option.
9. Click on the Test button.

Hint: To quickly set up the modem and insure the correct settings, choose the Detect button in the Serial Port Setup dialog box. Carbon Copy will accurately detect your modem and automatically select the correct settings.

Carbon Copy runs a short test to see if the settings will work. If they do work correctly, it presents a dialog box stating that the communications port and modem are OK (see Figure 11-7).

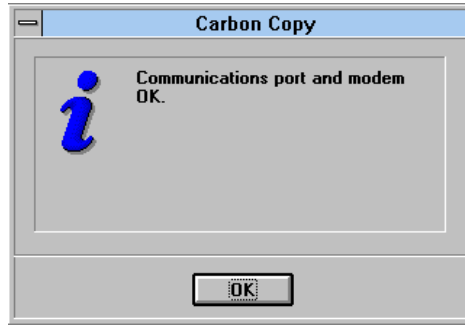

Figure 11-7: Carbon Copy confirms your communications port and modem are OK.

8. Click on the OK button. Carbon Copy closes the Serial Port Setup dialog box.
9. In the Communications dialog box, click on the OK button.

Carbon copy returns the focus to the Carbon Copy Host dialog box.

Security Options

You can set up a security system for each Remote site by assigning Login names and Login Passwords to a list of Guests and optionally, assigning each a callback number. If you do so, only Guests using appropriate Login Names and their matching Login Passwords will be able to use Carbon Copy to connect to your site. If you use the callback feature, your site will hang-up and call the Guest back.

To set up Login Names and Passwords:

1. Choose the **Utilities** menu and the **Password Table** menu item.

Carbon Copy will present the Password Table dialog box (see Figure 11-8).

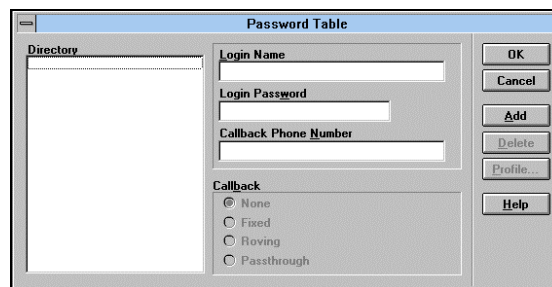

Figure 11-8: The Password Table dialog box.

2. Click on the Add button.

Carbon Copy presents the Add Password Table Entry dialog box (see Figure 11-9).



Figure 11-9: Add a Login name to your directory.

3. Type in the Login Name you wish to add and choose the OK button.
4. With your cursor now in the Login Password text box, type in the password you want to associate with this Login Name. As you type, only asterisks will show in the text box.
5. Choose the OK button.

Carbon Copy will present the Confirm Login Password dialog box (Figure 11-10).

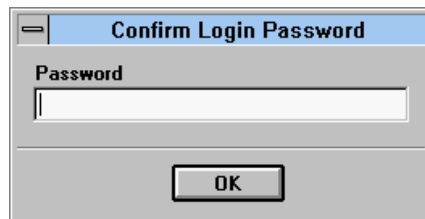

Figure 11-10: Retype the new password to confirm.

6. Retype the password just as you entered it in step 4 and choose the OK button.

Carbon Copy will present a Confirm dialog box if you have not yet told it to require passwords. To set Carbon Copy to require Guests to use passwords:

1. Select the **Options** menu and choose the **Security** menu item.

Carbon Copy presents the Security dialog box (see Figure 11-11).

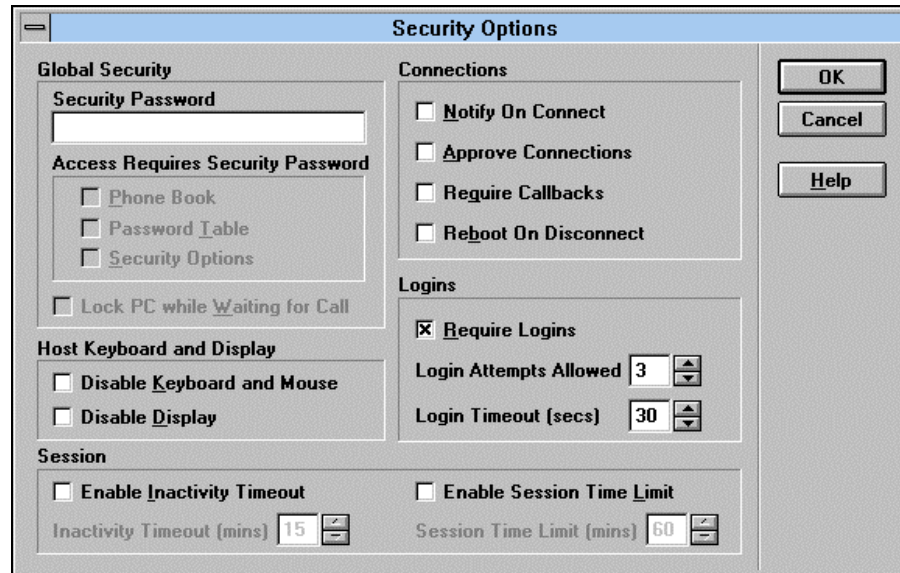

Figure 11-11: Use the Security dialog box to require Guests to use passwords.

2. In the Logins area, click on the Require Logins box and increase or decrease or simply type in the number of Login Attempts Allowed.
3. Choose the OK button.

With Login Required set, Guests must use one of your listed Login Names and its associated Login Password to make a connection and use Remote Control and the other Carbon Copy utilities.

***Note:** You can set up an elaborate or simple security system. Of course the simplest is no security system at all and keeping the Remote Site phone numbers confidential. By setting up just one Login Name and Password, all users needing to connect to your site can use the same name and password. By setting up a different Login name and Password for every possible caller, you can remove or change a login name when you no longer wish to authorize a former user to use the system. In this way, other users are not forced to learn a new login name and password. Each guest site and remote site can set up its own security system as well. The more elaborate the system, however, the more difficult it becomes to keep users and passwords straight.*

Editing or Deleting Login Names and Passwords

You can change Login Names and Passwords by opening the Password Dialog box, selecting a Login Name from the directory, and typing in any changes to it. You may also delete a Login Name by choosing the Delete button and then the OK button in the Confirm dialog box.

Setting up Callback

The callback feature will set options that has the Remote site call the Guest site back after the Guest's initial connection. In this way, the Remote site further secures itself from being called by unauthorized users. You can choose to have no callback (the default), Fixed callback, Roving callback, or Passthrough callback in effect.

Callback Options:

- | | |
|---------------------|--|
| None: | No callback. |
| Fixed: | You specify a single number with which the Remote site (Host) can call the Central site (Guest) back. |
| Roving: | The Guest user can type in a number at which the Host calls the Guest computer back. |
| Passthrough: | The Guest user can type in a number at which the Host calls back or type P to gain access to the remote site without callback. |

To set up the Callback option you wish to use:

1. In the Password Table dialog box (Figure 11-8) type in a callback number.
2. Select the None, Fixed, Roving, or Passthrough radio button.
3. Choose the OK button.

Configuring the Central Site

Checking and Setting Communications Options

Checking and setting the modem options for the Central or Guest computer is virtually the same as done for the Remote or Host computer (see page 11-3).

Setting Security Options

Checking and setting security options for the Central or Guest computer is virtually the same as done for the Remote or Host computer (see page 11-5).

Execute Upon Connection

You can set the Guest software to automatically start its Remote Control, File Transfer, Chat, Remote Clipboard, Remote Printing, or Remote Drive Access

when it establishes a connection to a Host E4900 computer. To set one or more of these utilities to start:

1. Select the **Options** menu and choose the **Execute Upon Connection** command.

Carbon Copy presents the Execute Upon Connection dialog box (Figure 11-12).

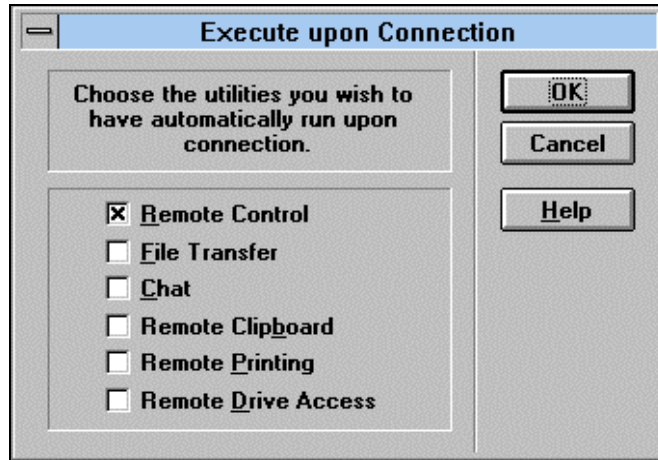

Figure 11-12: Tell Carbon Copy what utilities you want to start when your computer first connects to another.

2. Choose one or more of the available options. (Not all options run together.)
3. Click on the OK button to accept your settings.

Connecting to and Controlling a Remote Site

Configuring the Phone Book

While you may always type in a phone number to call when connecting to a remote computer, it is more convenient and prevents errors to have a directory to choose from. By taking the time to configure your directory, you can quickly connect to a remote site. This is especially useful when you are controlling multiple remote sites.

Adding an Entry

To prepare your phone list:

1. Select the **Utilities** menu and choose the **Phone Book** menu item.

Carbon Copy will present the Phone Book dialog box (see Figure 11-13).

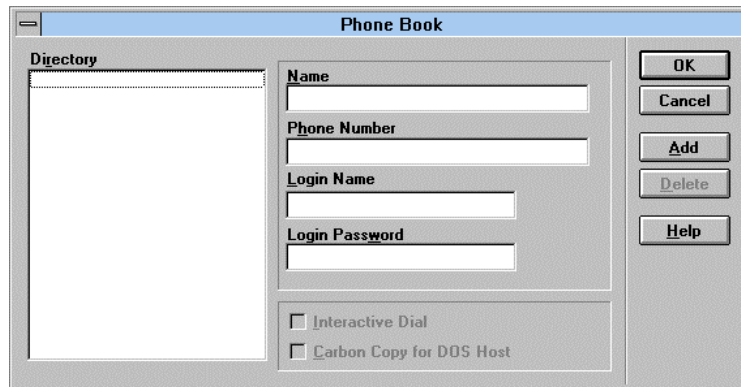

Figure 11-13: Create a directory to prevent dialing errors.

2. Click on the **Add** button

Carbon Copy will present an Add Phone Book Entry dialog box (Figure 11-14).

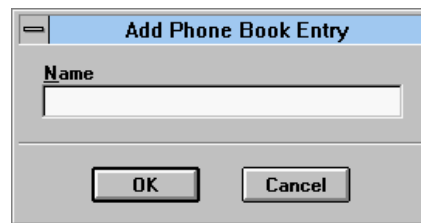

Figure 11-14: The Add Phonebook Entry dialog box.

3. Type the name of or some identifying title for the Host/Remote site you want listed first in your directory and press **Enter** or Click on the **OK** button.

Carbon Copy will close the Add Phone Book Entry dialog box and put the new name in both the directory and in the Name text box. Your cursor is now in the Phone Number text box.

4. Type the phone number that will call the Remote site named in the Name text box and press **Tab**.
5. With your cursor now in the Login Name text box, type a login name if appropriate (see Security Options page 11-5 above) and press **Tab**.
6. With your cursor now in the Login Password text box, if necessary, type the password for this site and press **Enter**.

Editing an Entry

To edit an entry in the Phone Book, open the Phone Book dialog box, select a name from the directory, and re-enter data related to that listing. For example, to record a new phone number for a listing, select that listing and then click in the Phone Number text box and type the new number.

Deleting an Entry

To delete an entry in the Phone book, open the Phone Book dialog box, select a name from the directory and choose the Delete button. Once you confirm the deletion, Carbon Copy will remove that entry from your directory.

Calling the Remote Site

Calling a Host

Before calling a Host computer:

- The Host computer's Carbon Copy software must be iconized in Wait for Call mode.
- Set the Central computer's software to execute Remote Control upon connection. This is its default mode.

***Note:** While Carbon Copy does support a Host computer calling a Guest computer, we do not explain this approach since usually you will have the Central or Guest computer call the Remote or Host computer. If it is necessary to have the Remote site call the Central computer to initiate remote control of the Remote site, you can do so, but you must be sure to have the Guest interface in the Guest-Wait for Call mode and iconized or it will not answer the call.*

To call a host computer:

1. In the Carbon Copy Guest window, click on the Call a Host button or select the Connection menu and the Call a Host command.

Carbon Copy will display the Call a Host dialog box. (Figure 11-15)

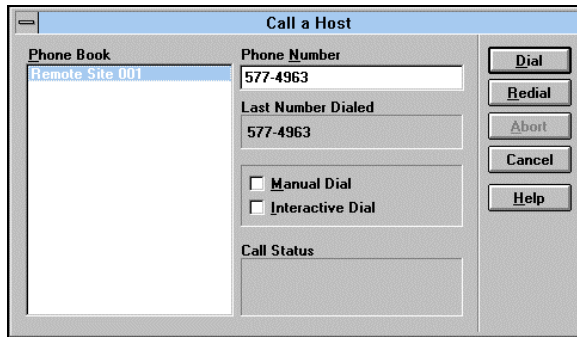

Figure 11-15: Call a host to make your connection.

2. Select a phone number by its name in the Phone Book or enter a phone number in the Phone Number text box.
3. Click on the Dial button.

Carbon Copy dials the number and displays the status of your call in the Call a Host dialog box. When your computers make a connection, Remote control will be in effect and your Guest computer will display the Host computer's screen.

Aborting a Call

If for any reason you must stop calling a Host after dialing, click on the Abort button before a connection is made. You may also prevent a call from completing by canceling the Call a Host dialog box. To do so, click on the Cancel button and Carbon Copy will abort the call and close the Call a Host dialog box.

Redialing

After each call you make, Carbon Copy displays the most recently called number in the Call a Host dialog box's Last Number Dialed box. Click on the Redial button and Carbon Copy will automatically call that number.

Setting the Reboot on Disconnect Option

As a precaution at least and as a maintenance strategy in some cases, you could first set the Remote site to reboot the system when your connection is inadvertently broken. In this way, Windows, Remote Control, and the SMS software will be started when something breaks the connection or applications lock up during operation. Without this feature, should your connection break unexpectedly, the Carbon Copy Host window may remain open instead of iconized, and it will not answer a call.

At other times you may need to make system changes to the Remote site's Windows software or DOS configuration files. To put these changes into effect,

you will need to reboot the Remote site and still have it be able to answer your next call.

In either case, you must have the system set up to restart Windows and the Carbon Copy software upon startup.

To configure the E4900 Windows system to be able to restart the SMS software and Carbon Copy, you must add this line to the WIN.INI

load= gsw.exe

Note: *If you start or are running a monitoring plan and using Reboot on Disconnect and your connection is broken, your monitoring plan will end and not restart on reboot! Scheduled plans whose start time passes while the system is rebooting will not be executed. See Chapter 6, Monitoring Under a Plan, and Chapter 7, Running and Controlling Your Monitoring Plan.*

To set the Reboot on Disconnect Option:

1. Double-click on the Carbon Copy Host Connected icon.
2. In the Carbon Copy Host Connected window, select the Options menu.
3. Select the Security... command. Carbon Copy opens the Security Options dialog box (See Figure 11-16.)

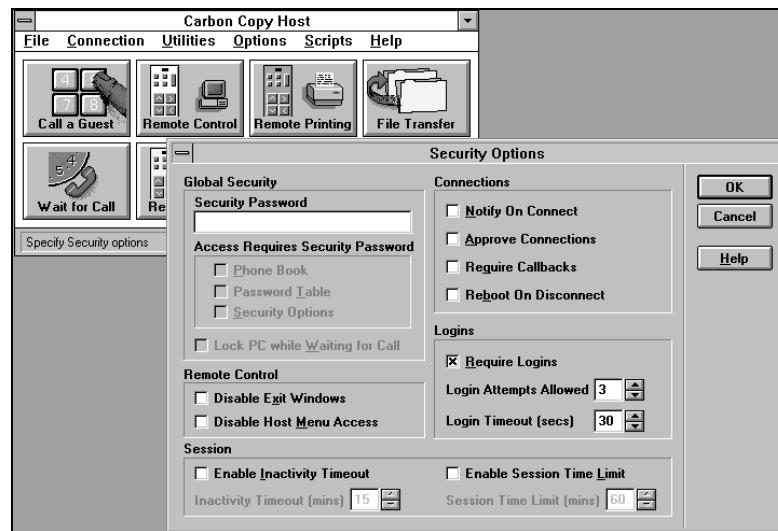

Figure 11-16: When you first make a connection, it is a good idea to turn on the Reboot on Disconnect feature.

4. Under the Connections area, click on the Reboot on Disconnect option. It must have a check mark for the the feature to be turned on.

In the normal course of your work, you will not need to have the Reboot on Disconnect option set when you disconnect. In your normal operation then, you will want to turn Reboot on Disconnect off before disconnecting from the Remote site. To turn Reboot on Disconnect off:

1. In the Carbon Copy Host Connected window, select the Options menu.
2. Select the Reboot on Disconnect option. It should not have a check mark next to it if it is inactive.

Starting the SMS Program

You can start any Windows program or any DOS-based program running in a Windows DOS box from the Central Site. You can therefore start the SMS software simply by double-clicking on the LAUNCHER icon in the SMS program group.

For ease-of-use, it is best to have the SMS software start up when Windows starts. Your System Administrator can prepare this for you using directions in Chapter 12, System Administration.

Using the SMS Program Remotely

Once started, Carbon Copy shows the same screen on the Central computer as you would see if you sat in front of the Remote computer's monitor. You can then operate the Remote computer as if you were using the Remote computer's keyboard and mouse. In this way you can operate the Remote site's E4900 software and control the E4900 hardware following the directions already given in this text.

Performing Remote File Management

Generating Reports

A major function of the Remote Control software is to make Remote site files readily accessible no matter where they may be physically located. The many reports you can generate using the SMS software thus become accessible from any Central or other Remote site.

You can use the Remote Control software to have a Remote site generate a report (see Chapter 8, Generating Reports) and then use Carbon Copy's file management software to copy or move those reports to your computer's hard drive, disk, tape backup, or other media. To read how to generate a specific report, see Chapter 8, Generating Reports.

Transferring Files from the Remote Site to a Central Site

Carbon Copy comes with a File Transfer utility that works very much like Windows File Manager. It performs equally for the Remote site as it does for the Central site. In this way, the Remote site can access files from its computer and the Guest computer, and the Central site can access files from its computer and the Host computer. Though they can both open File Transfer at the same time, only one user can copy files at a time.

The nomenclature can be confusing but the Guest Files window in the File Transfer interface refers to the computer that called. The Host Files window in the File Transfer interface refers to the computer called. (See Figure 11-17.)

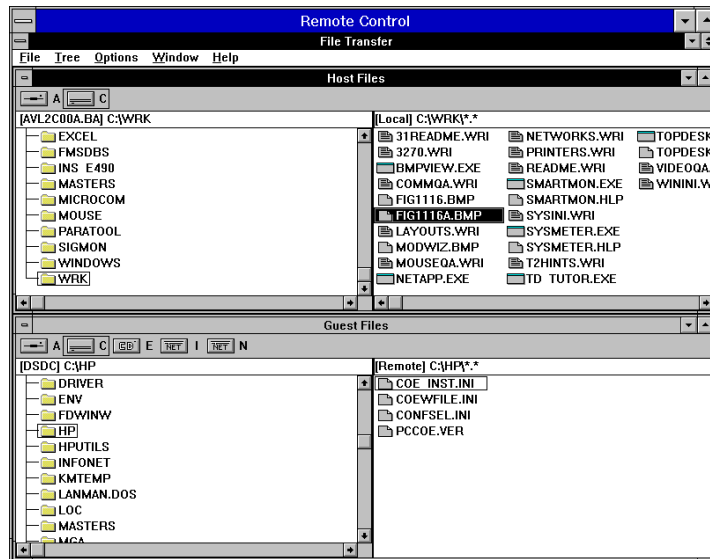

Figure 11-17: The Carbon Copy File Transfer interface resembles and performs like Windows File Manager.

***Note:** Just as in Windows File Manager showing two or more drives, you can have File Transfer display the Guest Files and Host Files trees in different ways. You can tile the windows so they appear one above the other or cascade them so they overlap each other.*

Copying Files

To start File Transfer and copy a file:

1. Click on the **File Transfer** button in the Carbon Copy Guest or Host Window
or
Select the **Utilities** menu and choose the **File Transfer** command.

Carbon Copy will open and display the File Transfer interface (Figure 11-17, above) on the local computer. A File Transfer icon will appear at the remote computer to notify the remote user that a file transfer may be in progress.

2. In the File Transfer interface, select the **Options** menu and the **Include...** command.

Carbon Copy presents the Include dialog box (Figure 11-18).

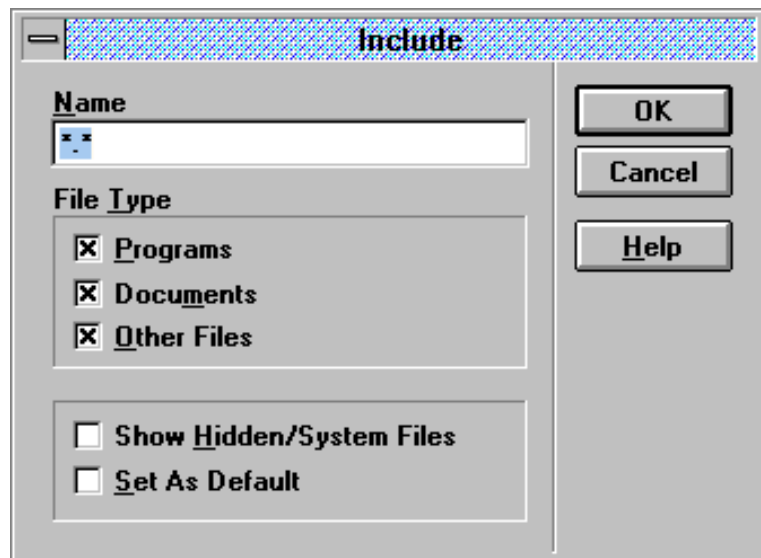

Figure 11-18: Control the files you view using the Include dialog box.

3. Select some or all file types to include in the File Transfer interface. You can limit your presentation to only SMS data files by typing *.TXT or with your spreadsheet program's extension (*.XLS for example) in the Name text box.
4. Close the Include dialog box and select the **Options** menu and the **Sort...** command to present the Sort By dialog box (Figure 11-19).

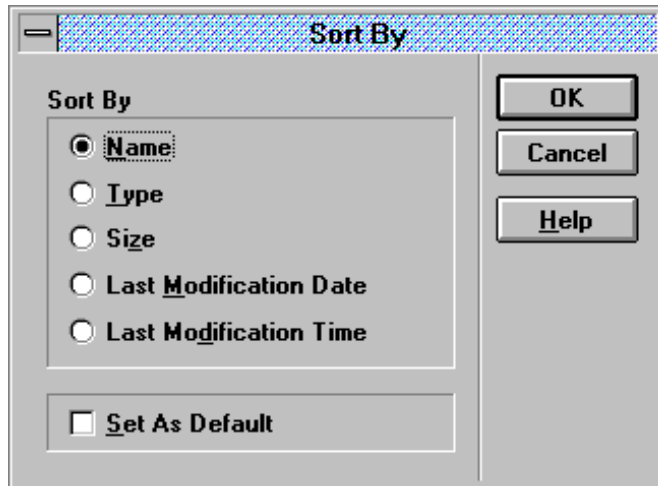

Figure 11-19: Organize your view of the files using the Sort By dialog box.

5. Choose how you want to see the files sorted.
6. Close the Sort dialog box and select (click on) a directory and a file or files from the remote window by:
 - Clicking on a single file name
 - Shift-clicking to select a sequential range of file names
 - Control-clicking to select a non-sequential group of file names
7. Select the **Options** menu and choose the **Transfer Options** command.

Carbon Copy will present the Transfer Options dialog box (see Figure 11-20). The options in this dialog box are self-explanatory. The Copy and Synchronize options help you keep iterations of files in order. Enable Crash Recovery insures you can complete the task even if your connection is lost during the transfer. Copy Newer Files Only speeds up a back-up routine.

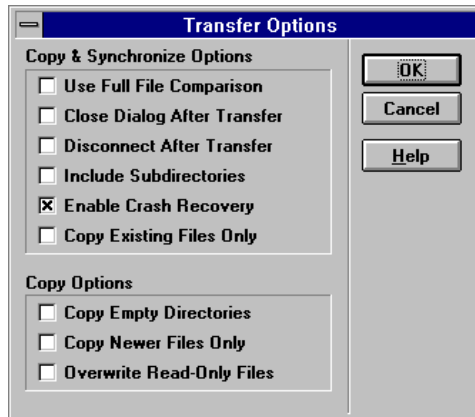

Figure 11-20: The Transfer Options dialog box.

8. Choose one or more transfer options that best meet your needs and press the OK button.
9. Select the File menu and the Copy command.

Carbon Copy will present its Copy dialog box (Figure 11-21) in which you can reset the destination drive and directory and modify the list of selected files.

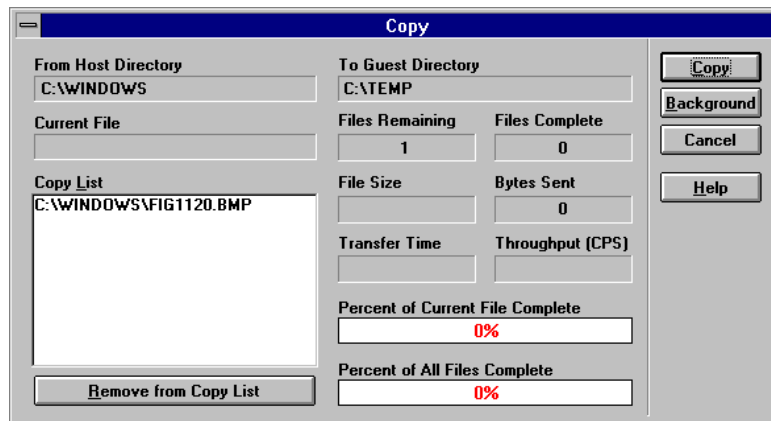

Figure 11-21: The Copy dialog box offers you a chance to check your selection and make necessary changes to it before you transfer the files.

8. Click on the Copy button or the Background button.

When you choose the Copy button, Carbon Copy shows the progress of the operation in the Copy dialog box. When you choose the Background button the operation occurs without your seeing the Copy dialog box and you may work in another application. When the copy is complete the Copy dialog box will appear and inform you of the operations results.

9. Click on the Close button.

***Hint:** You can also copy files by clicking and dragging the file name from the remote window to a drive and directory in the local window or vice versus.*

Deleting Files

You can easily delete files from your local or the Remote site using File Transfer. To do so:

1. Select the directory containing the target file and then a file or group of files (see Copying files, above)
2. Select the File menu and choose the Delete Files command

Carbon Copy presents the Delete Files dialog box (see Figure 11-22).

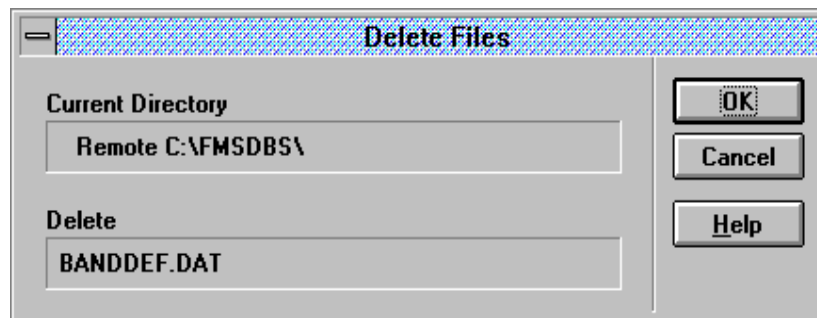

Figure 11-22: The Delete Files dialog box gives you a chance to not remove files by accident.

3. Read the list of files in the Delete text box and be sure you have chosen the correct file or files to delete.
4. Choose the OK button and Carbon Copy's File Transfer will remove the file or files from the selected directory.

Creating and Deleting Directories

You can quickly create and just as easily delete directories from your local or the Remote site using File Transfer.

To create a directory:

1. Select the directory tree (Guest or Host) and directory under which you want to create your directory.
2. Select the File menu and choose the Create Directory command.

Carbon Copy will present the Create Directory dialog box (Figure 11-23).

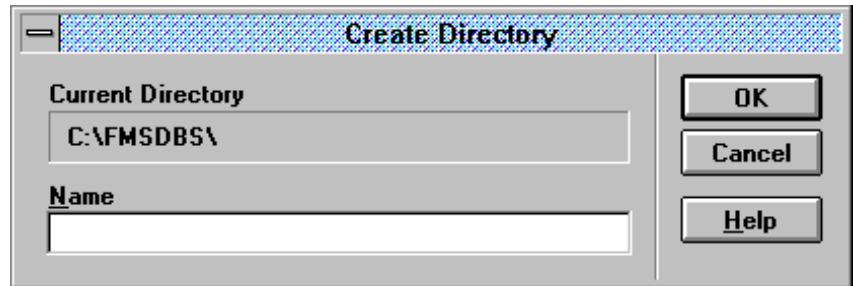

Figure 11-23: Create a directory on the remote computer.

3. Check that you have correctly selected the appropriate directory against what appears in the Current Directory box. Also, double check that you have chosen the correct tree (Host or Guest PC).
4. Type the name for the new directory in the Name text box.
5. Choose the OK button and File Transfer will add the directory name to the selected tree under the selected directory.

To remove a directory:

1. Select the directory tree (Guest or Host) and directory name you wish to remove.
2. Select the File menu and choose the Delete... command.

Carbon Copy will present the Remove Directory dialog box (Figure 11-24).

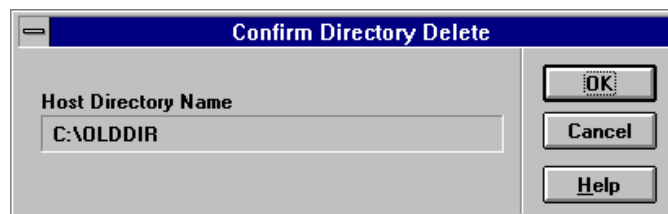

Figure 11-24: Remove a directory on the Host computer.

3. Check that you have correctly selected the appropriate directory against what appears in the Current Directory box. Also, double check that you have chosen the correct tree (Host or Guest PC).
4. Choose the OK button and File Transfer will remove the directory name from the selected tree.

Refreshing the Files Display

By choosing the Refresh command under the Windows menu, you can redraw the contents of the File Transfer window.

When you copy or delete files, File Transfer redraws and updates the Guest Files and Host Files windows dynamically. However, when you create a new directory or remove a directory or make changes to files or directories using Windows File Manager, you will not see the new information until after you close and restart File Transfer.

Viewing Reports with SMS Software

If you have the SMS software installed on the central computer, you can use its viewing utility to review any transferred report either as a graphic report or a text report. See “Viewing Saved Reports” in Chapter 8.

Viewing Reports without the SMS Software

If you do not have the SMS software installed at the central site, you can still view reports using one of the following three methods.

Using Paintbrush to View a Graphics File

To view a report using Windows Paintbrush:

1. Generate the report at the remote site.
2. Save the report as a graphics file (the .txt extension works).
3. Transfer the file as in “Transferring Files from the Remote Site to a Central Site” (page 11-15).
4. Use Windows Paintbrush at the central site to view the report.

Using Windows’ Screen-Grabbing Capabilities

To quickly view a report using Windows’ screen-grabbing capabilities:

1. Generate or view the report at the remote as described in Chapter 8.
2. Press Alt-Print Screen on the central site computer’s keyboard.
3. Open Windows Paintbrush at the central site.

4. Maximize the Paintbrush program window to insure the screen will accommodate the full image.
5. Choose the Edit menu and the Paste menu item.

Using Excel to View Data

You can also use your Excel spreadsheet program to view data. To do so:

1. Use the E4900 SMS software at the remote site's Export Data feature (see Chapter 9, Exporting Data).
2. Transfer the file as in "Transferring Files from the Remote Site to a Central Site" (page 11-15).
3. Import the file into Excel at the central site (see Viewing Exported Data in a Spreadsheet program, page 9-7).

Remote Drive Access

You can avoid the Carbon Copy File Transfer process by utilizing a shared drive. The Remote Drive Access feature allows you to access files on the remote site without having to transfer those files first to your Central site hard drive.

To set up a shared directory:

1. Select the **Options** menu and choose the **Drive Sharing Options** menu item.

Carbon Copy will display the Drive Sharing Options dialog box (see Figure 11-25).

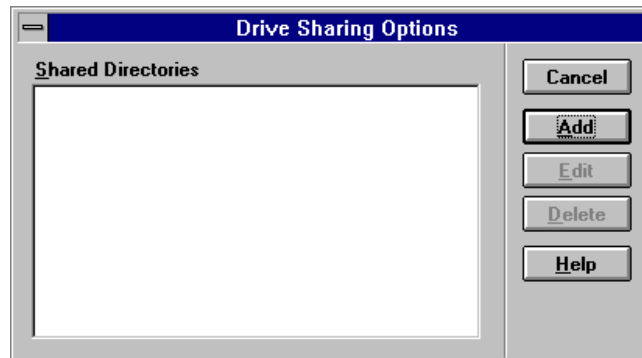

Figure 11-25: With a shared drive you can directly access data at the remote site.

2. Click on the Add button. The Share directory dialog box is displayed (see Figure 11-26).

The image shows a 'Share Directory' dialog box with a blue title bar. It contains several input fields and sections. On the right side, there are four buttons: 'OK', 'Cancel', 'Browse', and 'Help'. The main area is divided into three sections: 'Share Name', 'Path', and 'Description', each with a text input field. Below these is the 'Access Type' section with four radio button options: 'Full' (selected), 'Read-Only', 'None', and 'Depends on User'. At the bottom is the 'User Access' section, which is currently empty. To the right of this section is a 'Set Access' area with three buttons: 'Full', 'Read-Only', and 'None'.

Figure 11-26: Choose the drive and directory to share.

3. Type a name for the shared directory in the Share Name field.
4. Enter the location of the directory to share in the Path field.
5. If you wish, give a brief description of the shared directory in the Description field.
6. In the Access Type section, choose the type of access users will have to this directory:
 - **Full** Gives all users complete access.
 - **Read-Only** Users can read the files and copy files but must save changes as a new file.
 - **None** Users cannot access the files or make any changes to files.
 - **Depends on User** Set individual access rights per user.
7. Click on the OK button.

Once you have set up directories on the Remote site for sharing, you can then map them to a drive letter and they will appear as drives in File Manager. To do so:

1. Select the Utilities menu and choose the Remote Drive Access menu item.

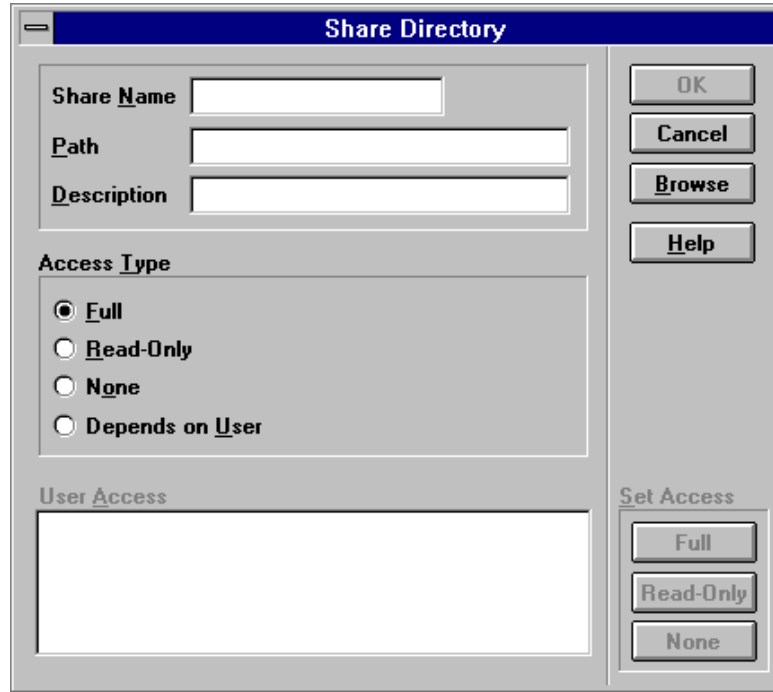
Carbon Copy displays the Remote Drive Access icon (see Figure 11-27) on both the Central site monitor and the Remote site monitor.



Figure 11-27: The Remote Drive icon.

2. Select the **Options** menu and choose the **Guest Drive Mapping** menu item to open the Guest Drive Mapping Options dialog box (see Figure 11-28).

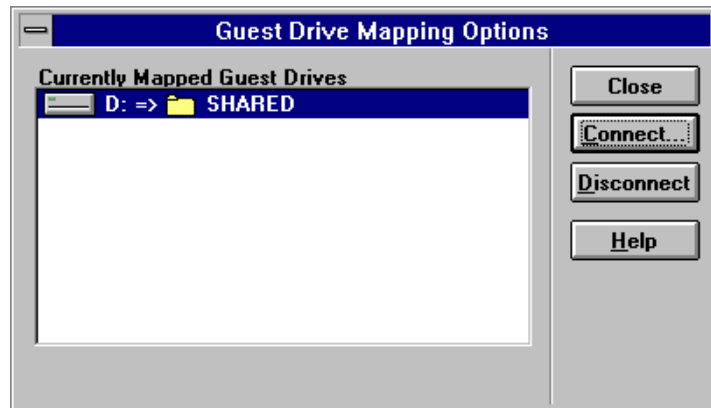

Figure 11-28: View existing mapped drive information and choose to connect to new ones using the Guest Drive Mapping Options dialog box.

3. Choose a directory and click on the **Connect** button. Carbon Copy opens the Connect Drive dialog box.
4. Click on the **OK** button and Carbon Copy will assign the drive letter to the shared directory. Carbon Copy returns to the guest Drive Mapping Options dialog box.
5. If you wish, assign other shared drives to a drive letter or disconnect existing shared directories from drive letters using the **Disconnect** button.
6. If you wish, click on the **Save as Default** box to insure maintain the drive settings for future use.

To exit remote drive access:

1. Click on the Remote Drive Access icon and select **Close**.

2. Select **Exit** to close Remote Drive Access.

Chatting with a Remote Site User

Chat is a utility that allows you and a Remote site user to converse by typing messages on-screen. It is the same program for the Central (Guest) and Remote (Host) interfaces.

Starting Chat

After making a connection using Remote Control, you or a Remote site user can start Chat. To do so:

1. Click on the Chat button in the Carbon Copy Guest or Host interface.

Carbon Copy will present the Chat dialog boxes for each interface (Figure 11-29 and Figure 11-30). If the Guest initiates the Chat, the Host user sees a, “The Guest wishes to chat with you” message. If the Host initiates the Chat, the Guest user sees a, “The Host wishes to chat with you” message.

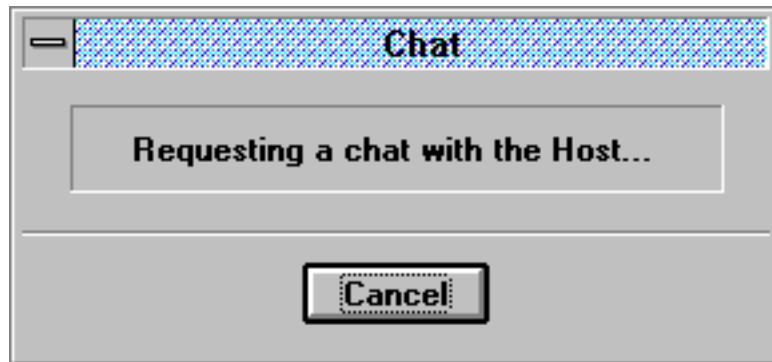

Figure 11-29: When a Guest requests a chat, Carbon Copy displays this dialog box. If the Host requests a chat this dialog box reads, "Requesting a chat with the Guest..."

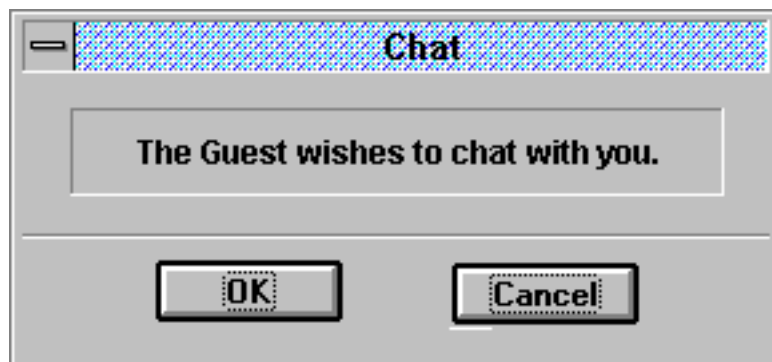

Figure 11-30: When a Guest requests a chat with a host, the Host computer displays this Chat dialog box. When a Host requests a chat with a guest, the Guest computer displays this Chat dialog box with , “The Host wishes to chat with you.” Choose OK to start Chat.

2. The other user must choose the OK button to begin the chat mode.

Carbon Copy presents the Chat window (Figure 11-31) on both computers' screens. (It does not matter who requested the chat, Guest is always local and Host is always remote.)

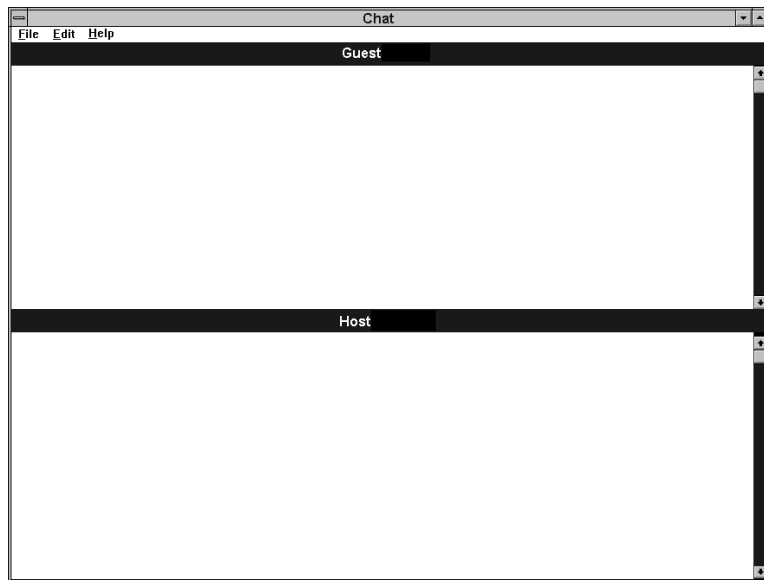

Figure 11-31: In Chat mode, both the Host user and Guest user can type simultaneously.

3. Both users can type at the same time using any ASCII character plus Ctrl+G (beep) and backspace.

***Hint:** It is helpful to take turns while using Chat. Use the Ctrl+G beep signal to tell the other user you are finished and awaiting a response.*

Scrolling and Saving Chat Conversations

As you and the other conversant using Chat continue your conversation, most of what you type can fit into a single screen. You can easily view text that may have scrolled out of view by clicking on the scroll bars. The Chat text interface cannot,

however, accommodate a great deal of text, and when full, it will replace the oldest text with new text as you continue to type.

You can save large amounts of Chat dialogue by copying it to the clipboard and pasting it into Windows Write or another text editing tool or word processor. You may then save the contents as an ASCII text file or format it as needed.

Exiting Chat

After you and the other user have finished your conversation, close the Chat window by choosing File, Exit or closing the Chat icon. Carbon Copy maintains the Remote Control connection.

Using the Remote Clipboard

As long as Remote Control is in operation, yours and the Host computer can share a common clipboard called the Remote Clipboard. You can cut or copy and paste between any two applications as long as you have Remote Clipboard turned on.

Starting Remote Clipboard

To start Remote Clipboard simply click on the Remote Clipboard button in the Guest Carbon Copy window.

Carbon Copy will display the Remote clipboard icon on both computers.

Copying Data with Remote Clipboard

You can copy data between computers using the Remote Clipboard by:

1. Selecting text or other items in a Windows or DOS application in one computer and copy or cut them to the clipboard as you normally would do in Windows.
2. Double-click on the Remote Control icon. Carbon Copy returns to the Carbon Copy Guest window and you can use your local applications.
3. Open the Windows application you want to put the data into and paste the data into place.

Disconnecting from a Remote Site and Exiting

When you connect to another computer, the Carbon Copy interface's Call a Host button changes to a Hang-up button. All you need to do to disconnect from another computer and end your Remote Control session is:

1. Display the Carbon Copy window (Alt+W, Alt+Tab, or Alt+Esc).
2. Click on the Hang-up button.
3. Choose Yes to confirm the disconnection.

Carbon Copy will hang-up your phone and disconnect the two modems.

System Administration

This section describes the software system administrative tasks for the setup, maintenance and support of your Spectrum Monitoring System.

This section is written for the System Administrator using common terminology for the operation and support of a personal computer. It is assumed that as an administrator, you are familiar with an IBM-compatible PC, the Microsoft DOS operating system, and the Windows environment under which the E4900 and E4903 Series Spectrum Monitoring Application Software runs.

Your Standalone/Remote Monitoring Site

Administrative Operations for E4900 Software

The Configuration of Your System Files

It is suggested that upon receipt of your System, you make backup disk copies of your System Files which include:

C:\AUTOEXEC.BAT

C:\CONFIG.SYS

C:\WINDOWS\SYSTEM.INI

C:\WINDOWS\WIN.INI

The following examples may vary from your system's configuration.

C:\AUTOEXEC.BAT file

```
@ECHO OFF

PROMPT $p$g
SET PATH=C:\DOS;C:\WINDOWS;C:\MOUSE;C:\SIGMON\BIN;C:\FMSDBS
SET LMOUSE=C:\MOUSE
C:\MOUSE\MOUSE
set temp=c:\windows\temp
c:\windows\setres\clmode m7
set comspec=c:\dos\command.com

rem smartdrv write caching off for E4900
LH c:\windows\smartdrv.exe /c 1024 512
```

```

rem share required for E4900
LH c:\dos\share.exe

rem Time zone to prevent automatic adjustment
rem for daylight savings in E4900 scheduler.
SET TZ=PST8

call c:\sigmon\config\showlic.bat
win

```

C:\CONFIG.SYS file

```

DEVICE=C:\dos\HIMEM.SYS
DEVICE=C:\dos\EMM386.EXE NOEMS x=DC00-DFFF
DOS=HIGH,UMB
FILES=50
BUFFERS=30
STACKS=12,256
SHELL=c:\dos\command.com c:\ /p /e:1024
DEVICEHIGH=c:\dos\display.sys con=(EGA,437, 1)
DEVICEHIGH=C:\DOS\SETVER.EXE
DEVICEHIGH=C:\DOS\POWER.EXE ADV:MAX
DEVICEHIGH=C:\PLUGPLAY\DRIVERS\DOS\DWCFGMG.SYS /NOLOCK

```

Note: Your AUTOEXEC.BAT and CONFIG.SYS files may differ slightly from the above.

System Initialization Files for E4900 Software

Within the E4900 Spectrum Monitoring software for a Monitoring Site are files used to initialize the various executable routines of the application software. Most of these files have a *.INI extension. The majority of the *.INI files are **not** to be modified. However, a small number of these files contain initializing statements that may be edited by the System Administrator to selectively modify the operation of the SMS.

The following subsections address **only** the files that are of interest to the System Administrator and describe what allowable editing may be performed on these files to customize the operation of the system.

Caution: Some of the E4900 files that you may edit are also duplicated in the E4903 application software for a Central Site and must be edited in concert with the same files when a Remote Monitoring Site is to be operated from a Central Site.

These initializing files are added during the loading of the E4900 application software and are contained in either the WINDOWS directory or in the CONFIG directory, the paths to which are:

```
C:\ WINDOWS [files]
```

C:\ SIGMON \ CONFIG [files]

The files may be viewed and edited by using the Windows Notepad file text editor. When viewed with Notepad, the files are displayed by sections with Section Headings appearing as bracketed text. Statements are inactive when preceded with a semicolon (;). Conversely, statements without a preceding semicolon are active.

For brevity, only the file sections in each file that **may** be edited by the System Administrator are directly addressed.

*Caution: Do **not** edit any files or sections of files that are not directly addressed. Failure to heed this cautionary warning may "crash" your application software.*

E4900 Initialization Files in the WINDOWS Directory

Table 12-1: Editable E4900 Files added to WINDOWS Directory

FMSMENU.INI	DATACLR.INI	STAT_DEF.INI	OCCBW.INI
SMSCNFG.INI	PROCBOS.INI	SA60E.INI	SYSBK.INI
SA63EL.INI	SA66.INI	SA67.INI	SA91E.INI
SA93E.INI	SA94E.INI	SA68.INI	MHOS.INI
TWM.INI	REMFIL.INI	LOGINFO.INI	CFALRM.INI
AM_ALRM.INI	BAND_DEF.INI	SA61E.INI	PFALRM.INI
MAXPRALM.INI	OCC_DEF.INI	CAR_DEF.INI	DATABAK.INI
SNALRM.INI			

The files in Table 12-1 that are highlighted are those of interest to the System Administrator and are addressed in detail as follows:

Table 12-2: SMSCNFG.INI

```
[REMOTE]
Site=StandAlone

[SMSMAINAPP]
WinTitle=HP E4900 Series Spectrum Monitoring System (Opt 003)
Editor=Write

;SVG A SETTINGS FOR BAR FONTS AND SIZES
;800 by 600 or better
SVG ABarFont=Helv
SVG ABarFontSize=250
//SVG ABarFont=Courier New
//SVG ABarFontSize=200
SVG ABarWidth=110
SVG ABarCharOffset=60
```

```
;VGA SETTINGS FOR BAR FONTS AND SIZES
;640 by 480 (Laptop Models)
VGABarFont=Times New Roman
VGABarFontSize=200
VGABarWidth=95
VGABarCharOffset=0
```

```
;SVGA SETTINGS FOR CLIENT MDI WINDOW BAR FONTS AND SIZES
;800 by 600 or better
//CLMDISVGABarFont=Helv
//CLMDISVGABarFontSize=300
CLMDISVGABarFont=Helv
CLMDISVGABarFontSize=200
CLMDISVGABarWidth=120
CLMDISVGAYOffset=10
```

```
;VGA SETTINGS FOR CLIENT MDI BAR FONTS AND SIZES
;640 by 480 (Laptop Models)
CLMDIVGABarFont=Helv
CLMDIVGABarFontSize=200
CLMDIVGABarWidth=100
CLMDIVGAYOffset=5
```

```
; Listed below are colors which can be used
; in the MDI window
;BLACK
;WHITE
;RED
;GREEN
;DGREEN
;BLUE
;LBLUE
;PURPLE
;YELLOW
;BROWN
;GRAY
;BLUGRAY
```

```
;This Changes Colors for Trace Window for
;Multiband Window and Spectrum Analyzer Traces
[PANTRACE]
GridColor=GRAY
TextColor=YELLOW
TraceColor=GREEN
BkColor=BLACK
ThresholdColor=BLUE
```

```
;This Changes Colors for Falling Raster Window for
;Multiband Window and Spectrum Analyzer Traces
```

```
[FARTRACE]
FarTraceColor=WHITE
FarBkColor=BLUE
```

```
[REPGEN]
;Settings for the report generator
;SVGA SETTINGS FOR FONTS AND SIZES
;800 by 600 or better
//SVGAFont=Courier New
//SVGAFontSize=15
SVGAFont=Courier
SVGAFontSize=12
```

```
;VGA SETTINGS FOR FONTS AND SIZES
;640 by 480 (Laptop Models)
VGAFont=Courier New
VGAFontSize=15
```

```
[FREPOWER]
;Settings for the report generator
;SVGA SETTINGS FOR FONTS AND SIZES
;800 by 600 or better
SVGAFont=system
SVGAFontSize=5
```

```
;VGA SETTINGS FOR FONTS AND SIZES
;640 by 480 (Laptop Models)
VGAFont=MS Sans Serif
VGAFontSize=10
```

```
[HELPPFILE]
FileName=c:\sigmon\config\E49CONT.HLP
```

```
;used by icom receiver
```

```
003 [COM1]
;---PORT SETTINGS
baud=9600
parity=none
numbits=8
stopbits=1
flow=off
```

```
;// used for tape recorder
```

```
003 [COM2]  
;---PORT SETTINGS  
baud=2400  
parity=even  
stopbits=2  
numbits=7  
flow=off
```

```
[Launcher]  
AppName=RemoteLaunch
```

```
[ReceiverControl]  
FREQLIMIT=25e6  
FREQUPLIMIT=1999.9999e6
```

```
[RxControl1]  
//default values that receiver is initialized to  
FREQ=97.3e6  
MOD=WFM  
ATTEN=OFF  
AUDIO=ON
```

```
RxAppName=RxControl1
```

```
[RxControl2]  
FREQ=98.5e6  
MOD=WFM  
ATTEN=OFF  
AUDIO=OFF  
RxAppName=RxControl2
```

```
[SAProcess]  
HplibCard=7  
Address=18  
HplibTimeOut=4  
LocalLockOut=FALSE  
;AttribFile=sa66.ini  
;AttribFile=sa68.ini  
AttribFile=sa91e.ini  
;AttribFile=sa93e.ini  
;AttribFile=sa94e.ini  
;AttribFile=sa60e.ini  
;AttribFile=sa61e.ini  
;AttribFile=sa62e.ini  
;AttribFile=sa63e.ini
```

```

[DCESwitchControl]
HpibCard=7
Address=9
HpibTimeOut=2

[DBServer]
dbpath=c:\fmsdbs
//TimeInterval to Flush Database and check for
//FreeDiskSpace (in seconds)
TimeInterval=60

//FreeDiskSpace Left before E4900 Can no longer
// store data and warning message appears (in MEGABYTES)
FreeDiskSpace=2

[SLP]
TimeSpan=30

[STAT]
TimeSpan=300
Threshold=-80.00

[RFSWITCHCONTROL]
Active=FALSE
Option=YES
pathdata=c:\sigmon\config

[DATACORRECTION]
Action=ON

[MASKING]
Active=FALSE
DefaultMask=demo1.msk

[CARMEAS]
Threshold=10.0

[VERSION]
SERIES=HP E4900 OPT 003           or =HP E4900 OPT 001 or =HP E4900
RELEASE=1.20
DATE=10/10/95

;
; - For Priority - 1 is the highest priority ....
;

[Priority]
// If NumPriority is set to 0, then priority handoff is disabled
NumPriority=0

```

[Pri1]
Priority=1
StartF=95.0e6
StopF =97.0e6

[Pri2]
Priority=2
StartF=430.0e6
StopF= 432.06

[Pri3]
Priority=3
StartF=921.0e6
StopF =922.0e6

003 [HANDOFF]
TimeSpan=30
MaxHandoffBuffSize=40
IgnoreRangeFreq=15.0e3

003 [RecorderControl]
TapeApp=TapeControl1

003 [Rx Name]
insts=3!Rx1!Rx2!Rx3!

003 >[Rx1]
RxAppName=RxControl1
TapeAppName=TapeControl1

003 [Rx2]
RxAppName=RxControl2
TapeAppName=TapeControl2

003 [Rx3]
RxAppName=RxControl3
TapeAppName=TapeControl3

Using Different Spectrum Analyzers

To change the type of Spectrum Analyzer you use, exit the SMS program and from Program Manager, run ICONFIG. In addition, make the following modifications to the sections below.

Table 12-3: MHOS.INI

```
;
; Carrier Handoff Alarm Settings: MHOS.INI (HP E4900)
;
; Lines beginning with ";" are comments.
;
; Spectrum analyzer settings for optional carrier measurements triggered
; by an Alarm action of a Signal Logging measurement definition.
;
```

```
[MeasHandoff]
Span = 30e3
RB = 1e3
VB = 1e3
ST = 500e-3
```

E4900 Initialization Files in the C:\SIGMON\CONFIG Directory

Table 12-4: Editable E4900 Files in C:\SIGMON\CONFIG Directory

RFPATH.INI	DEMO1.MSK	DEMO3.MSK	TABLE2.INI
CARTYPE.INI	DEMO2.MSK	TABLE1.INI	TABLE3.INI

All files in Table 12-4 are of interest to the System Administrator and are addressed in detail as follows:

Table 12-5: RFPATH.INI

```
#
# RF Path Selection: rfpath.ini (HP E4900)
#
# Lines beginning with a "#" are comment lines.
#
# User can enter their own path names, for example to name Path1
# change the line Path1=pathname to Path1=yourname (20 characters max,
# no spaces). Then insert your pathname in the appropriate section
# of this file. Also, enter new UserTitle in the section of this file
# with your pathname if desired.
```

```
#
# Enter your start and stop frequencies. Now insert the correct
# switch commands to create your path. "9" is the factory shipped
# address for the switch. On the next line you can enter your own
# comment, such as "Amplifier switched out". On following line
# identify which correction table has your path calibration data.
#
```

[Header]

```
NumPaths = 3
Path1=AMP OUT
Path2=AMP IN
Path3=Default
```

```
001/003[AMP OUT]
```

```
UserTitle = Antenna 1
StartFreq = 9.00 Khz
StopFreq = 1800.00 Mhz
Command = OPEN 100;
SwitchAddr = 9
UserComment = Amplifier switched out
TableName = table1.ini
```

```
001/003[AMP IN]
```

```
UserTitle = Antenna 1
StartFreq = 100.00 Khz
StopFreq = 1300.00 Mhz
Command = CLOSE 100;
SwitchAddr = 9
UserComment = Amplifier switched in
TableName = table2.ini
```

[Default]

```
UserTitle = Antenna 1
StartFreq = 9.00 Khz
StopFreq = 1800.00 Mhz
Command = OPEN 100;
SwitchAddr = 9
UserComment = Amplifier switched out
TableName = table1.ini
```

Table 12-6: CARTYPE.INI

```
;
; Carrier Marker Handoff settings: cartype.ini (HP E4900)
;
; Lines begining with ";" are comments.
;
; Spectrum analyzer settings used when a carrier measurement is
; performed as a marker handoff action in Spectrum Analyzer Window.
;

[Header]
NumTypes=4
Path1=AM
Path2=NFM
Path3=WFM
Path4=USER 1 (TV)
LastType=WFM

[AM]
Span=40e3
RB=1e3
VB=1e3
ST=500e-3

[NFM]
Span=30e3
RB=1e3
VB=1e3
ST=500e-3

[WFM]
Span=500e3
RB=10e3
VB=10e3
ST=100e-3

[USER 1 (TV)]
Span=5e6
RB=100e3
VB=100e3
ST=50e-3
```

Generation of Mask Files

Three identical demo mask files are included in the `sigmon\config` directory. Mask files are generated off line using the Windows utility **Notepad**. To generate a **Mask File** double click on **Accessories** and then **Notepad** in the **Program Manager** opening the **Notepad** window (Figure 12-1). The following figure shows a typical mask definition example where the bands 123.4 - 124.5 MHz and 152.0 - 153.0 MHz are defined to be masked.

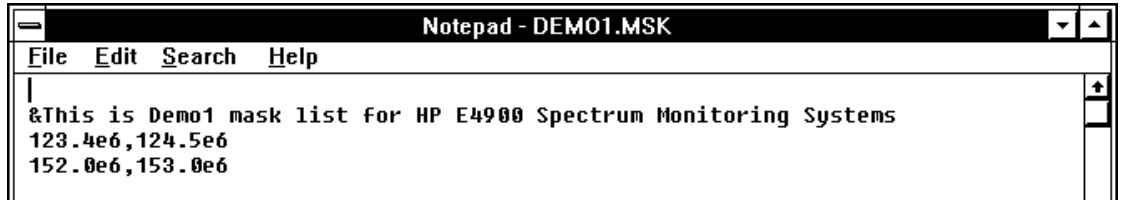

Figure 12-1: Typical Mask Definition On Notepad

To define your own parameters in a new **Mask File** open a blank **Notepad** window and enter your own frequency limits for bands to be masked in scientific notation as shown in the example. You may include an optional descriptive comment line preceded by the symbol `&`. When entry is complete, save the mask file with a unique file name with an `*.msk` extension (e.g. `c:\sigmon\config\[yourfile.msk]`).

Table 12-7: DEMO_.MSK

```
& HP E4900 Mask table: demo1.msk
&
& Lines beginning with '&' are comments.
&
& Each line is one pair of frequencies separated by a comma.
&
& If masking is active and selected as part of an Occupancy or Signal
& Logging measurement definition, any signals occurring between any
& frequency pairs will be ignored.
&
123.4e6,124.5e6
152.0e6,153.0e6
98.1e6,107.9e6
```



Table 12-8: TABLE1.INI
TABLE3.INI

Factory default values of the three configurations are identical, hence only 1 description is given.

E Only TABLE1.INI applies.

#

RF Path Correction table: table1.ini (HP E4900)

```

#
# Line begins with a '#' sign is a comment line.
# First character of the last line in this file must be set to '!'
#
# *****
# * IMPORTANT: Values are correction values, not database values,
# * therefore amplifier gain is entered as -20 for example, NOT 20,
# * and attenuation values as 10 for example, NOT -10.
# *****
#
# Correction entries should be placed immediately below the last
# comment line. Entry line should be in the following format with
# each field separated by space(s) or tab(s).
#
# Frequency AntennaGain(-) CableLoss(+) AmplifierGain(-)
9e3          0          0          0
10e3         0          0          0
100e3        0          0          0
1e6          0          0          0
10e6         0          0          0
100e6        0          0          0
1000e6       0          0          0
1800e6      0          0          0
!

```

003 Table 12-9: TABLE2.INI

```

#
# RF Path Correction table: table1.ini (HP E4900 opt.003)
#
# Line begins with a '#' sign is a comment line.
# First character of the last line in this file must be set to '!'
#
# *****
# * IMPORTANT: Values are correction values, not database values,
# * therefore amplifier gain is entered as -20 for example, NOT 20,
# * and attenuation values as 10 for example, NOT -10.
# *****
#
# Correction entries should be placed immediately below the last
# comment line. Entry line should be in the following format with
# each field separated by space(s) or tab(s).
#
# Frequency AntennaGain(-) CableLoss(+) AmplifierGain(-)
100e3       0          0          -25
1e6         0          0          -25
10e6        0          0          -25
100e6       0          0          -25
1000e6      0          0          -25
1300e6     0          0          -25
!

```

Your Spectrum Monitoring System is designed to provide dependable service. It is unlikely that you will experience a problem. However, Hewlett-Packard's worldwide sales and service organization is ready to provide the support you need.

If You Have a Problem

Seeking Help

If you have a problem, refer to the following for possible help:

- E4900 Reference Manual
- Online Glossary (Help file)
- Readme file
- Respective documentation for system components including the HP-IB Interface Board
- HP Spectrum Analyzer Users Guide
- Vectra Users Guide
- Microcom System Carbon Copy software

If you still have a problem, please read the warranty printed at the front of this manual, then contact the nearest HP Sales and Service Office. If your Spectrum Monitoring System is covered by a separate support agreement, please be familiar with its terms.

Checking Hardware

The response of the E4900 system is very dependent on the state of the hardware, check these conditions first:

1. Security key attached to parallel port;
2. Spectrum analyzer is attached to PC via HP-IB cable;
3. Spectrum analyzer is on and has completed its power up sequence (trace on SA is displayed and being updated);
4. If you have option 001 or 003 - be sure devices are on and attached to their respective ports;

Checking Software

If you suspect the hardware is at fault, the troubleshooting process is to manually verify the hardware is working, then the PC interface.

If you suspect the problem is in the software, carefully re-read the sections in the reference manual that pertain to the task you were trying to perform. If after consulting the reference manual, you are still having problems, use our fax service. A form is in the on-line help and at the end of this chapter. The more complete the information you give us, the faster your problem can be resolved.

If the message **Raima Database error ...** appears you will need to re-link the database. Exit SMS, and from Program Manager run `C:\fmsdbs\keybuild fms`.

If you know the Band the SMS program used on the SA, try entering the settings from the SA's front panel. If you are unfamiliar with SA operation consult the SA Users Guide.

If the problem you are experiencing involves the data on the spectrum analyzer display not matching the SMS displayed data, check that the model number displayed at the top of the SA control window matches the model SA you are using. If it does not, you will need to run the hardware config program `iconfig.exe`. The trace data may not match exactly if you have path correction turned on.

A DOS program is available to verify the interfaces (HPIB and serial) are working correctly. This program should be run from DOS without Windows running. Type `C:\sigmon\config\e49test`. This executes a program that will enable simple commands to be sent to the SA verifying the HPIB's operation.

To check the SA type 2, do tests 1-3. Verify the SA changes with each test. If these tests pass, the HPIB interface is functioning correctly. Verify the steps leading to your initial problem still cause the problem. If the problem still remains use our fax service.

Verifying the HP3488 Switch



The 3488 switch unit switches in the preamplifier in the path. It is not controlled directly, but through the "RF Path" in either BAND definition or CONTROL SA. From the CONTROL SA window, set up the SA with a signal on screen, with an amplitude of approximately -30dBm. Change the RF Path between paths with "... amplifier switched in" and "... amplifier switched out". The trace on the SA's display should change by greater than 20dB.

If the signal moves, but not by >20dB, the preamplifier is not working correctly. Be sure you are not in gain compression, input power should be < -20dBm.

If no gain change is apparent, use the following procedure to manually verify the HP3488 Switch:

1. Connect the SAs' cal signal to the antenna cable input.
2. On the SA, press IP, Center Frequency 300MHz (if you are using an 8566B, 8567A, or 8568B, Center Frequency will be 100MHz), Span 1MHz.

3. The signal should be ~ -20DBm (-10DBm for 8566B, 8567A, or 8568B). If it is not, cycle power on the HP 3488.
4. If the signal is above top screen on the SA, a stuck switch is indicated. From the 3488 front panel, press “close 100 exec”, the signal on the SA’s display should go higher. Press “open100 exec”, signal on SA should drop to its previous level.

Next, verify the remote operation of the switch unit.

1. With the same setup as above, Type “C:\sigmon\config\e49test”,
2. Enter 2 at the prompt for the switch test.
3. From the switch Test menu, enter 1.
4. Observe the SA display. Trace should be moving up and down.

If there is no movement:

- Make sure the GPIB cable is correctly attached.
- Check the SA for remote operation. If it works correctly, the problem is in the 3488, if not, the GPIB CARD is not working properly.

003

Verifying the Receiver

To verify the receiver:

1. Use the Receiver front panel controls to change frequency, and demod type.
2. Listen to a known signal.

If the receiver appears to be working correctly, use the Hardware test program to check the serial interface.

1. Type C:\sigmon\config\e49test
2. Enter 4 for the receiver test.
3. Do tests 1-3, verifying that the settings change on the receivers display.

003

Verifying the Recorder

To verify the recorder:

1. Set the Receiver to a station with voices present
2. Press the record key.
3. Level leds should indicate a signal, if not check the CH 1 level control, it should be full CCW and the AUT red led should be lit.

If the recorder checks out manually, use the Hardware Test Program to check the serial interface.

1. Type `C:\sigmon\config\e49test`
2. Enter 5.
3. Do tests 1 and 2.

Calling HP Sales and Service Offices

Sales and service offices are located around the world to provide complete support for your Spectrum Monitoring System. To obtain support information, contact the nearest Hewlett-Packard Sales and Service office listed in the Preface. In any correspondence or telephone conversations, refer to the Spectrum Monitoring System by its product number and full serial number. With this information, the HP representative can quickly determine whether your unit is still within its warranty period and how to help you as quickly as possible.

Additional Support Services

Using Online Help

Online Help provides a convenient, quick way to look up definitions of terms used in the SMS software. You can access Help through the help menu.

Help Contets

For information on Help topics, choose **Contents** from the Help menu. You can use the Contents screen to get quick access to key reference topics.

Choose:

1. **Back** to return to previously viewed information.
2. **History** to view a complete, sequential list of every Help topic you viewed during the current session.
3. **Customer Support** to locate information about a number of support services.

FAX Support Line

A fax sheet is provided at the end of this chapter as a method in which to directly contact the HP SMS support team in the event of a problem. The fax cover sheet provides the SMS support team with information about your company, the product, and a detailed description about the problem.

***Note:** All items on the fax cover sheet **must** be completed in order to expedite your response. Any incomplete item may delay your response.*

Simply copy the fax cover sheet, fill out the requested information, include any additional information sheets, and fax the sheet(s) to **HP SMS Support** at **(707) 577-4200**. Depending on the complexity of the problem, you should receive a response back within a few days.

FAX Cover Sheet

To: HP E4900A Support FAX Number (707) 577-4200

Page ____ of ____

Date Transmitted _____

Time Transmitted _____

From: Company: _____

Last Name: _____ First Name: _____

Address: _____

City: _____ State: _____

Country: _____ Postal Code: _____ Mail Stop: _____

Telephone Number: (Include Country Code): _____

Fax Number (required): _____

HP E4900A Serial Number: _____ Rev: _____

Software Loaded on System: (attach copies of AUTOEXEC.BAT and CONFIG.SYS files)

Can the problem be reproduced? Yes No

Detailed Problem Description: (include all setup information and any additional pages)

This document contains two main sections: system capabilities and system specifications. System specifications describe the system's warranted performance. The system capabilities section explains the functionality of the system and contains numerous supplemental characteristics. Supplemental characteristics are typical but nonwarranted performance parameters.

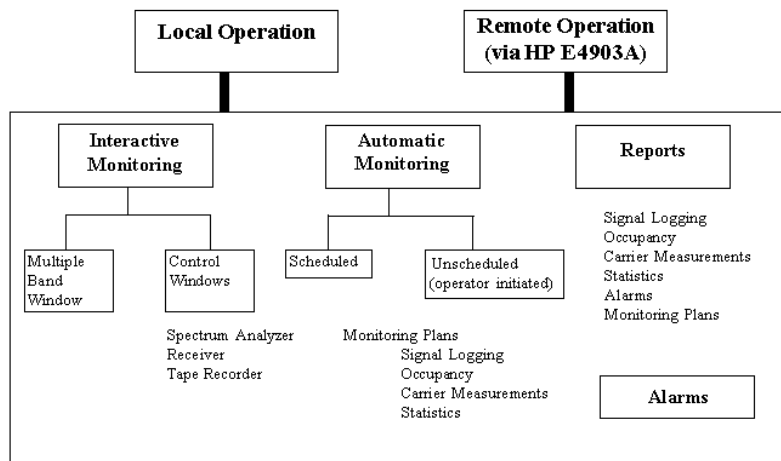

Figure 14-1: HP E4900 Operational Overview

System Capabilities

Measurement

HP E4900 systems can perform both interactive and automated measurements. Interactive measurements allow the operator to investigate signals rapidly. Interactive measurements include observation of multiple bands in multiple formats, hand-off of signals to carrier measurements, control of the spectrum analyzer, optional receiver and optional tape recorder. Automated measurements may be commanded to happen under operator control or scheduled to occur without an operator present. Powerful capabilities such as task scheduling and alarms can be used to coordinate signal logging, carrier measurements, and spectral occupancy and statistical measurements. RF path management, including amplitude correction, applies to all measurements made by the system.

Band Definition

All measurements in HP E4900 systems are performed in user-selected bands. Systems are shipped with several predefined bands containing recommended settings for common communications bands. Users may also create and name custom bands up to a maximum of 50 total bands defined.

Band definitions include all appropriate spectrum analyzer settings: start and stop frequency or center frequency and span, resolution bandwidth, video bandwidth, sweep time, attenuation, reference level, and detection mode. Information about the use of these parameters is contained in chapter 5. The HP E4900A has analog resolution bandwidths from 1 kHz to 3 MHz in a 1, 3, 10 sequence for general purpose monitoring. The HP E4901A and E4902A improve sensitivity and selectivity by adding 1 Hz to 300 Hz resolution bandwidths. Resolution bandwidths of 1 Hz to 100 Hz are implemented digitally in order to minimize measurement time. Sweep times can be set between 50 ms and 60 s.

Frequency span is unlimited from zero to the entire frequency range of the system. Frequency span is typically set to the width of a band to observe band activity or set to the channel spacing for carrier measurements. Normally, bands should be defined to be no more than 25 channel widths in order to assure legible displays and reports and accurate channelization and signal hand-off.

RF Path Management

HP E4900 systems include two important system capabilities: amplitude correction and path control.

Amplitude correction is accomplished with a user-defined table of electrical loss/gain factors and antenna factors versus frequency. This allows measurements to be calibrated for the effects of cable losses, filter attenuation, and preamplifier gain as well as the actual performance of the monitoring antenna. Amplitude correction is applied to all measurements and displays.

HP E4900A Option 001 and 003 systems and custom systems add path control. These systems have RF distribution networks including preamplifiers, switches, and possibly multiple antennas. Each RF path has a separate table of amplitude correction factors. Bands can be associated with paths so that the RF path is switched by band and the appropriate amplitude correction factors are applied.

Multiple Band Window

The multiple-band window is a tool for interactive spectrum observation. The multiple-band window can display up to eight bands at once by time sharing the spectrum analyzer. Windows features such as cascading, tiling, scaling, minimization, and maximization allow the display to be customized for most

convenient presentation. Approximate trace update times are shown in the table below. Sweep times can be set between 50 ms and 60 s.

Table 14-1

Model Number	Trace Update Time	
	Single Band	Multiple Band (per band)
HP E4900A	300 ms + sweep time	1 s + sweep time
HP E4901A	500 ms + sweep time	600 ms + sweep time
HP E4902A	500 ms + sweep time	600 ms + sweep time
HP E4902A Option 021	200 ms + sweep time	250 ms + sweep time

Bands can be displayed in three different formats: trace, waterfall, and spectrogram. The trace format is a good choice for seeing the power of time-invariant signals like broadcast signals. The trace display is an amplitude-corrected spectrum analyzer display. Waterfall and spectrogram displays are useful for viewing time-variant signals such as paging signals or two-way radios. The spectrogram display is an excellent visual tool to observe time durations of transmissions.

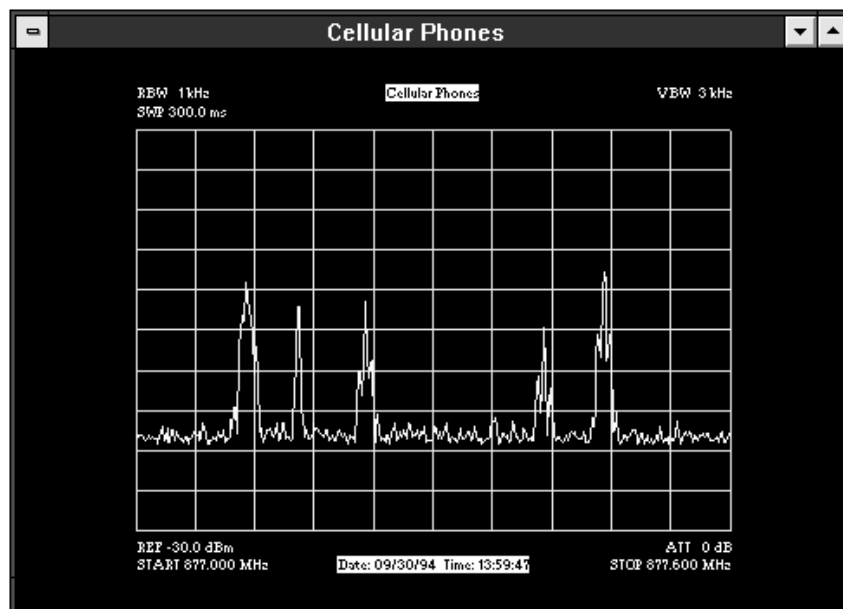

Figure 14-2: Trace Display with Power on the x axis and Frequency on the y axis.

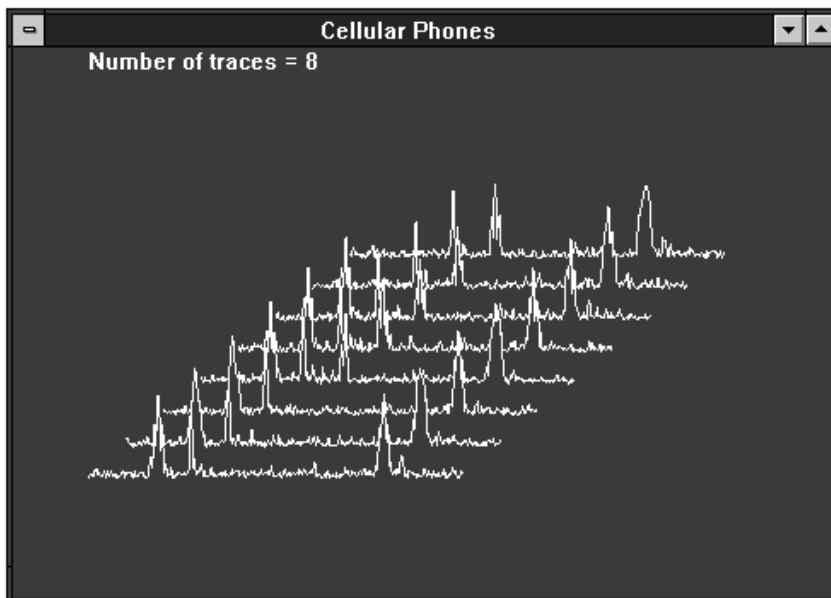

Figure 14-3: Waterfall display with Power on the x axis, Frequency on the y axis and Time on the vertical plane. In this view the front-most graph is the oldest measurement.

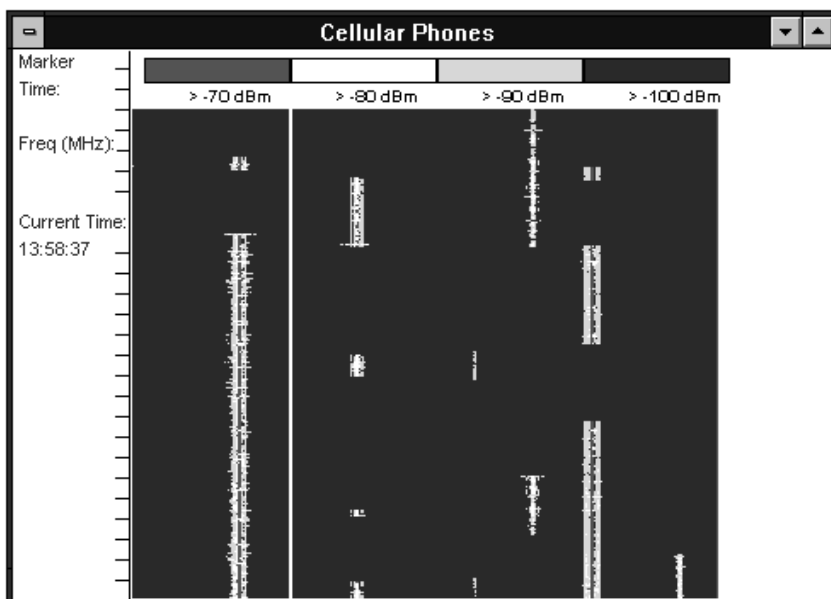

Figure 14-4: Spectrogram Display with Time on the x axis and Frequency on the y axis.

Markers can be placed on a signal to read out power and frequency. HP E4900 Option 003 systems can also automatically tune the receiver to the marker frequency.

Spectrum Analyzer Control

A spectrum analyzer window allows direct control of spectrum analyzer functions. Measurements in a single band can be displayed in the same three formats used in the multiple-band window (trace, waterfall, and spectrogram). Marker signals can be handed off to carrier measurements and optional demodulation. In addition, the spectrum analyzer window adds capabilities to:

- interactively recall, edit, and save band definitions,
- graphically define profiles and observe thresholds, both user-defined and automatic noise-riding.

Demodulation and Recording

HP E4900A Option 003 systems add a receiver and tape recorder for demodulation and recording of analog voice signals. HP E4901A and E4902A systems can be customized to include this feature.

The frequency range for demodulation is 25 MHz to 1.8 GHz. Demodulation modes available include AM, FM (normal and wideband), and SSB (USB and LSB). The receiver can be controlled interactively via the receiver control window or by being tuned by the marker function. Alarms can trigger the receiver and recorder automatically.

The tape recorder has a ± 3 dB bandwidth of 300 Hz to 3.4 kHz and records at 1/4 speed (15/32 ips) for a recording capacity of six hours on a standard C-90 cassette. A tape recorder control window automates playback and high-speed transport functions.

Signal Logging

Signal logging is a tool for automatic monitoring of the spectrum. Signal logging can include trace storage, signal storage with masking and threshold processes, as well as detection of new signals through an alarm process.

Traces can be saved with time and date stamps to the hard disk for future analysis. Trace consumption of disk capacity is summarized in the table below. In order to conserve disk space, the number of traces saved is limited to 400 per executed measurement. Saved traces can be viewed in trace, waterfall, and spectrogram formats using the archived trace feature of the multiple-band window.

Table 14-2

Model Number	Trace Size		Total Free Disk Space	Maximum Saved Traces
	# of points	# of bytes		
HP E4900A	401	3.25 k	400 MB	100,000
HP E4901A	601	3.25 k	400 MB	100,000
HP E4902A	601	3.25 k	400 MB	100,000
HP E4902A Option 021	1,001	3.25 k	400 MB	100,000

Signals can also be logged to the hard disk as power and frequency pairs. Each set of signals consumes approximately 3.2 kilobytes. Signals are defined as any peak above a threshold. The threshold can be defined in three ways:

1. user-defined threshold — the user defines one power level for all frequencies,
2. automatic noise-riding threshold — the system sets the threshold based on the measured noise floor, and
3. profile threshold — the user defines the threshold as a set of contiguous line segments in the power, frequency plane.

Masking, an aid to the signal logging process, can eliminate signals known not to be of interest. The system will not log signals inside user-defined frequency ranges. With automasking, the system builds its own mask based on signals present during the first measurement. The system reports all signals present on the first measurement and reports only new signals in subsequent measurements. To log all signals periodically, the mask may be discarded regularly according to a user-defined time interval.

The signal logging process can be coupled with the alarm process so that intermittent signals can be captured. Signals within user-defined power and frequency limits can trigger alarm actions.

Carrier Measurements

Carrier measurements can be performed either manually by placing the marker on the signal in the spectrum analyzer window, or automatically. Carrier measurements can also occur as the result of an alarm condition. Carrier measurements consist of seven measurements: center frequency, maximum and average power, signal-to-noise ratio, occupied bandwidth, amplitude modulation, and profile compliance. The first five measurement results are computed based on the maximum value of several traces. Measurement conditions such as sweep time, span, resolution bandwidth, and video bandwidth can be defined uniquely for each band. Measurement results outside of user-defined limits can trigger alarms.

Center Frequency: HP E4900 systems measure center frequency using the centroid technique. The center frequency is that frequency at which half the power is below in frequency and half is above. Accuracy is dependent on user-defined frequency span and resolution bandwidth. With frequency span of 30 kHz and resolution bandwidth of 1 kHz, HP E4900A typical frequency accuracy is 1 kHz (400 Hz for HP E4901A and E4902A).

Maximum and Average Power: Maximum power is determined by the highest peak on the maximum hold trace. Average power is the mean power over the defined span. Typical power measurement accuracy is ± 3 dB.

Signal-to-Noise Ratio: Signal-to-noise ratio is determined by comparing the maximum power to the measured noise. The noise level is the minimum value of the maximum hold trace. For signal-to-noise ratios up to 80 dB, typical measurement accuracy is ± 2 dB.

Occupied Bandwidth: HP E4900 systems measure occupied bandwidth using the “x dB” technique. The occupied bandwidth is the frequency difference between the frequencies at which the sidebands are x dB below the maximum power. Occupied bandwidth is usually measured at either 6 or 26 dB down; the x dB number is user-defined. For spans less than 2 MHz, typical measurement accuracy is $\pm 5\%$.

% Amplitude Modulation: Amplitude modulation is measured by taking two sweeps in zero span. One sweep uses positive peak detection and determines the maximum modulation by averaging the highest 1% of the trace points. The second sweep uses sample (HP E4900A) or negative peak (HP E4901A or E4902A) detection to determine the minimum modulation by averaging the lowest 1% of the points of the trace. Percentage amplitude modulation is then computed with a typical measurement error of $\pm 6\%$.

Profile Compliance: Profile compliance allows signals to be tested against a user-defined mask. The mask is drawn as a set of connected line segments in the power, frequency plane. Profile compliance reports the percentage of trace points that are below the profile. Profile compliance is especially helpful for testing signals against masks, for example to check a signal for compliance to standards. Go/no go decisions on profile compliance may be performed by coupling profile compliance to alarms. Also, profiles may be used in signal logging to detect new signals in the presence of several known signals.

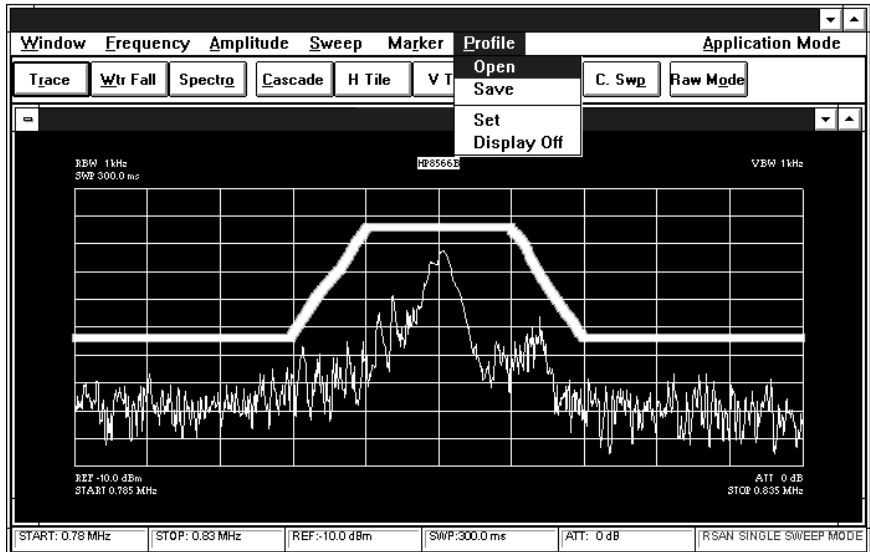

Figure 14-5: Profile defined for testing known signal.

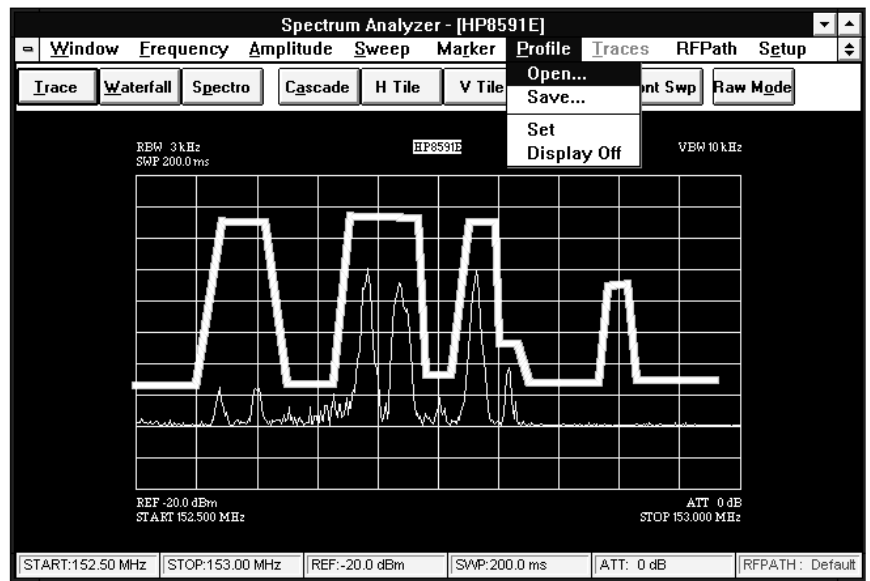

Figure 14-6: Profile defined for detecting new signals in signal logging.

Spectral Occupancy

Spectral occupancy provides information on long-term usage of the spectrum. These measurements are particularly useful for allocating frequencies for best spectral economy or for verifying that reserved bands are indeed free from interference prior to installing communications systems.

Spectral occupancy is channelized. By dividing the band by a user-defined channel spacing (1 kHz to 10 MHz), continuous frequencies are partitioned into discrete channels. Bands should contain no more than 25 channels due to display resolution and span accuracy considerations. Bands having more than 25 channels can be divided into sub-bands.

HP E4900 systems provide two types of occupancy measurements: running and interval. Running occupancy provides a single report for the entire time the measurement was running. Interval occupancy can export data with one set of values per user-defined time interval during the total measurement time. For example, if the measurement runs for three weeks, running occupancy would return one report averaging activity over that time period. Interval occupancy would export a spreadsheet of data with multiple entries, for example, every hour on the hour.

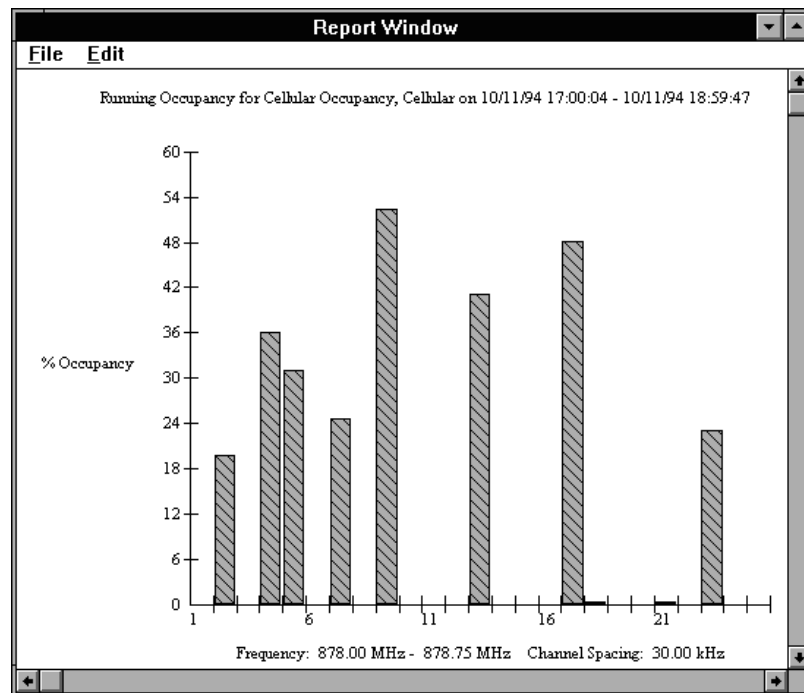

Figure 14-7: Running Occupancy report.

There are two results of occupancy measurements: channel occupancy and message length. Channel occupancy is the percentage of time that a given channel was occupied. Message length is the time duration of each transmission. Running occupancy and maximum and average message length are reported in bar graph format. Interval occupancy and maximum and average message length can be exported to a spreadsheet. An example of a running occupancy report is shown below.

The occupancy process can also be linked to masking (see Signal Logging) and alarms. Messages longer than a user-defined message length can be passed on to trace storage and optional demodulation using alarms.

Statistical Measurements

Similar to spectral occupancy, HP E4900 systems can also provide statistical measurements. Bands are divided into channels in the same way as in spectral occupancy.

Channelized power can be used to characterize the noise floor for channelized communications like analog cellular or TDMA and noise-sensitive communications like CDMA. Maximum and average power can be plotted by channel or output to a spreadsheet as a matrix with values for each user-defined time interval.

HP E4900 systems can also plot channel availability, the converse of occupancy. Variable threshold channel availability can be displayed in order to see how channel availability varies with threshold.

Coordination

In order to improve productivity of existing operators, HP E4900 systems automate measurements with a powerful suite of coordination capabilities. Task scheduling allows unattended monitoring 24 hours-a-day, 365 days-a-year with minimal operator attention. Multitasking allows the system to time share between multiple tasks in multiple bands, using a single set of equipment for a broad range of needs. Alarms track intermittent signals so they can be measured and recorded even when an operator is not present. Lastly, remote operation allows a single operator at a central site to coordinate monitoring in multiple sites without traveling.

Task Scheduling

Unattended monitoring can be performed by scheduling measurements to happen at specific times. Measurements are associated with bands and grouped into sets which can be executed either under operator command or scheduled to occur automatically. This allows measurements to be made at specific times of the day when an operator is not present. The schedule can be created and edited using the user-friendly windows interface. Examples of a monitoring plan and a monitoring schedule are shown in Figure 14-8 and Figure 14-9 below.

Multitasking

Because the system is multi-tasking, measurement plans can consist of multiple measurements. For example, the system can timeshare between spectral occupancy in cellular and paging bands, signal logging in public safety bands, and carrier measurements in the FM broadcast band. Reports can be viewed without

interrupting scheduled measurements. Multiple band window can be used to test measurement plans.

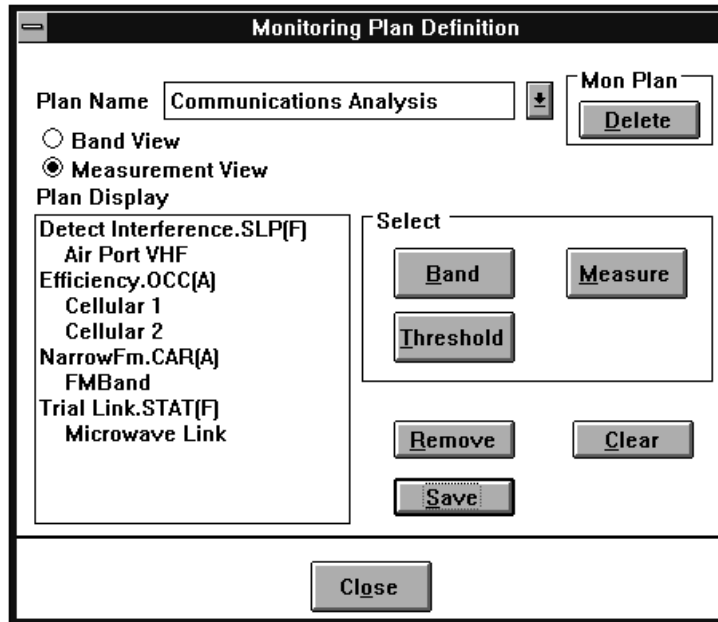

Figure 14-8: Example of a Monitoring Plan.

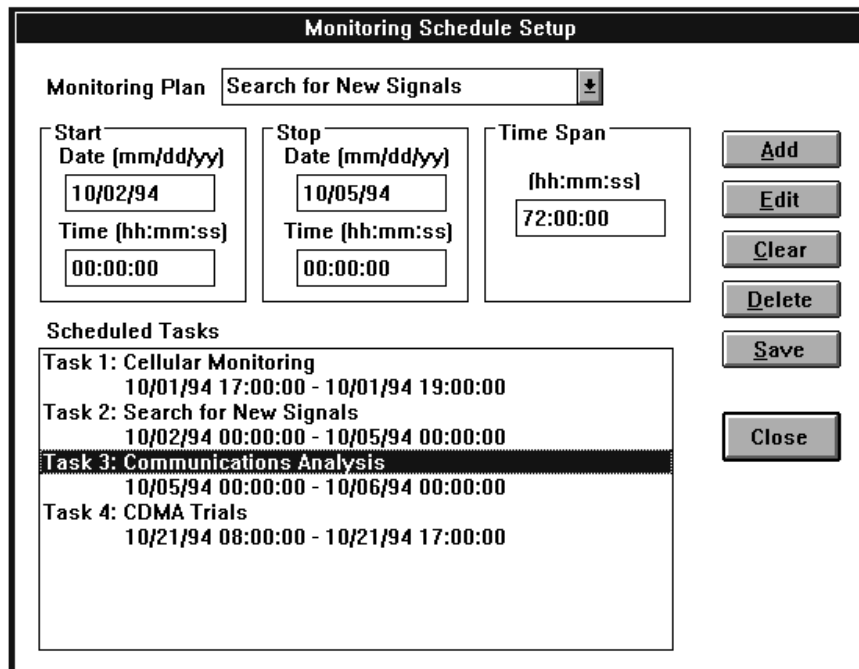

Figure 14-9: Example of a Monitoring Schedule.

Alarms

Alarms can be set to capture intermittent events such as interfering or illegal transmissions. Alarms can be triggered by each of the three main measurement processes: signal logging, carrier measurements, and spectral occupancy. When an alarm condition is satisfied, the triggering event and results are stored in an alarm log, and three different alarm actions can occur:

1. Traces can be saved to disk for later analysis.
2. Carrier measurements can be made and saved to disk.
3. The signal can be demodulated and recorded for later listening. (HP E4900A Option 003 only)

Table 14-3 summarizes alarm types, trigger conditions, and actions.

Table 14-3

Alarm Type Measurement Parameter	Trigger Conditions				Alarm Actions		
	Below Limit	Above Limit	Between Limits	Outside Limits	Trace Storage	Carrier Meas	Demod.& Record
Signal Logging							
Frequency			•		•	•	•
Power			•		•	•	•
Carrier Measurement							
Center Frequency				•	•		•
Maximum Power	•	•	•		•		•
Average Power	•	•	•		•		•
Signal-to-Noise Ratio	•				•		•
Occupied Bandwidth	•	•	•		•		•
% Amplitude Modulation	•	•	•		•		•
Profile Compliance	•				•		•
Spectral Occupancy							
Channel Up Time		•			•		•

Remote Operation

With a modem connection between systems, the HP E4903A central site controller can control HP E4900A, E4901A, and E4902A systems located at inconvenient or inaccessible sites. All measurements, coordination capabilities, and reports can be commanded from the central site. In systems having multiple remote sites, the E4903A central site controller can command all sites by logging into them one at a time.

Reports

HP E4900 systems can generate reports about every type of measurement as well as the measurement schedule and list of alarms detected. A wide variety of standard reports are available to suit most purposes. For specialized report formats or reports in local languages, HP E4900 systems can export data to standard PC software tools for writing custom reports.

Standard Reports

The system can generate a variety of text and graphical reports including reports on signal logging, carrier measurements, spectral occupancy and statistical measurements, monitoring plans, and alarm logs. These reports are summarized in Table 14-4 on page 14-14.

Custom Reports

Custom reports can be generated with a variety of standard PC software tools. There are two methods for generating custom reports.

Graphic displays from the system can be copied to the windows clipboard and then saved to a bitmap file using a supplied windows accessory called PaintBrush. These graphics files can then be included in word-processed reports. Displays that can be saved include trace and spectrogram displays, occupancy bar graphs, or any screen display, including menus and measurement definitions.

Measured data, as well as monitoring plans and band definitions, can be exported to files that are compatible with PC software tools such as Microsoft[®] Excel and Borland Quattro Pro spreadsheets and numerous word processors. Data can then be manipulated with these tools for inclusion in custom reports. Table 14-4 on page 14-14 summarizes standard reports plus exportable data.

Table 14-4: Summary of standard reports plus exportable data

Category	Measurement	Report Type			
		Text	Bar Graph	Line Graph	Data Export
Signal Logging	Signal Logging	•			•
Carrier Measurement	Carrier Measurement	•			•
Spectral Occupancy	Running Channel Occupancy		•		•
	Running Average Message Length		•		•
	Running Maximum Message Length		•		•
	Interval Channel Occupancy				•
	Interval Message Length				•
Statistical Measurements	Running Maximum Power			•	
	Running Average Power			•	
	Running Maximum vs. Average Power			•	
	Running Channel Availability		•		
	Running Variable Threshold Channel Availability			•	
	Interval Maximum Power			•	
	Interval Average Power				•
	Interval Channel Availability				•
	Interval Variable Threshold Channel Availability				•
Monitoring Plan	Monitoring Plan	•			•
Alarm Logs	Signal Logging Alarms	•			
	Occupancy Alarms	•			
	Carrier Measurement Alarms	•			
Bands	Band Definitions				•

System Specifications

HP E4900A 1.8 GHz Spectrum Monitoring System

System includes HP 8591E spectrum analyzer, HP Vectra PC with UVGA monitor and pre-loaded spectrum monitoring system software running under MS-DOS® and MS Windows®.

Option 001 improved RF sensitivity: adds preamplifier, switches, software to coordinate RF path switching, and rack and table

Option 003 improved RF sensitivity plus VHF/UHF demodulation and recording: adds preamplifier, switches, demodulation receiver, tape recorder, software to coordinate RF path switching, receiver hand-off, and tape recorder control, and rack and table

Option 011 adds 25 to 1300 MHz omnidirectional disccone antenna

Option 220 adds 220/240 volt operation

Option W30 provides two additional years return-to-HP service

Frequency Range:	HP E4900A:	9 kHz to 1.8 GHz
	HP E4900A Option 001/003 (preamp off):	9 kHz to 1.8 GHz
	HP E4900A Option 001/003 (preamp on):	100 kHz to 1.3 GHz

Displayed Average Noise Level:	frequency	rbw	DANL
HP E4900A	1 MHz to 1 GHz	1 kHz	-115 dBm
	1 GHz to 1.8 GHz	1 kHz	-113 dBm
HP E4900A Option 001/003 (preamp off)	1 MHz to 1 GHz	1 kHz	-107 dBm
	1 GHz to 1.8 GHz	1 kHz	-104 dBm
HP E4900A Option 001/003 (preamp on)	1 MHz to 1.3 GHz	1 kHz	-125 dBm

Third-Order Intermodulation Product: <-70 dBc (HP E4900A or HP E4900A Option 001/003 with preamp off)

Input:

Type N (f), 50 Ω

VSWR: < 2:1

Maximum Power:

+10 dBm (HP E4900A, 0 dB input attenuation)

+30 dBm (HP E4900A, input attenuation >= 10 dB)

-20 dBm (HP E4900A Option 001/003, preamp on, 0 dB input attenuation)

+10 dBm (HP E4900A Option 001/003, preamp off, 0 dB input attenuation)

+30 dBm (HP E4900A Option 001/003, preamp off, input attenuation >= 10 dB)

Size:

Spectrum analyzer (HP E4900A):	163 mm (H) x 325 mm (W) x 427 mm (D)
Rack (HP E4900A option 001/003):	1120 mm (H) x 600 mm (W) x 905 mm (D)
PC:	125 mm (H) x 420 mm (W) x 390 mm (D)
Monitor:	438 mm (H) x 422 mm (W) x 410 mm (D)

Weight:

Spectrum analyzer (HP E4900A):	20 kg
Rack (HP E4900A Option 001):	129 kg
Rack (HP E4900A Option 003):	145 kg
PC:	11 kg
Monitor:	17.7 kg

Power Consumption:

HP E4900A:	440 W maximum
HP E4900A Option 001/003:	560 W maximum

Temperature Range:

HP E4900A:	10j to 40jC specified
HP E4900A Option 001/003:	10° to 40°C operating, 20° to 30°C specified

HP E4901A 2.9 GHz Spectrum Monitoring System

System includes HP 8560E spectrum analyzer, HP Vectra PC with UVGA monitor and pre-loaded spectrum monitoring system software running under MS-DOS® and MS Windows®.

Option 011 adds 25 to 1300 MHz omnidirectional discone antenna

Option W30 provides two additional years return-to-HP service

Frequency Range: 100 kHz to 2.9 GHz

Displayed Average Noise Level:

frequency	1 kHz rbw	1 Hz rbw
1 MHz to 10 MHz	-110 dBm	-140 dBm
10 MHz to 2.9 GHz	-114 dBm	-144 dBm

Third-Order Intermodulation Product: -78 dBc

Input:

Type N (f),	50 Ω
VSWR:	< 2:1

Maximum Power:

- +10 dBm (0 dB input attenuation)
- +30 dBm (input attenuation \geq 10 dB)

Size:

Spectrum analyzer:	163 mm (H) x 325 mm (W) x 427 mm (D)
PC:	125 mm (H) x 420 mm (W) x 390 mm (D)
Monitor:	438 mm (H) x 422 mm (W) x 410 mm (D)

Weight:

Spectrum analyzer:	20 kg
PC:	11 kg
Monitor:	17.7 kg

Power Consumption: 440 W maximum

Temperature Range: 10° to 40°C

HP E4902A 26.5 GHz Spectrum Monitoring System

System includes HP 8563E spectrum analyzer, HP Vectra PC with UVGA monitor and pre-loaded spectrum monitoring system software running under MS-DOS® and MS Windows®.

Option 011 adds 25 to 1300 MHz omnidirectional discone antenna

Option 021 improved measurement speed: upgrades spectrum analyzer to HP 8566B Option 002

Option W30 two additional years return-to-HP service

Frequency Range: (HP E4902A) 9 kHz to 26.5 GHz
 (HP E4902A Option 021) 100 Hz to 22 GHz

Displayed Average Noise Level:

frequency	1 kHz rbw	10 Hz rbw	1 Hz rbw
HP E4902A			
1 MHz to 10 MHz	-110 dBm		-140 dBm
10 MHz to 13.2 GHz	-114 dBm		-144 dBm
13.2 GHz to 26.5 GHz	-109 dBm		-139 dBm
HP E4902A Option 021			
1 MHz to 2 GHz		-134 dBm	
2 GHz to 5.8 GHz		-132 dBm	
5.8 GHz to 12.5 GHz		-125 dBm	
12.5 GHz to 18.6 GHz		-119 dBm	
18.6 GHz to 22 GHz		-114 dBm	

Third-Order Intermodulation Product:

-75 dBc (HP E4902A)
 -70 dBc (HP E4902A Option 021)

Input:

Type N (f), 50 Ω
VSWR: < 2:1

Maximum Power:

+10 dBm (0 dB input attenuation)
 +30 dBm (input attenuation ≥ 10 dB)

Size:

Spectrum analyzer (HP E4902A): 163 mm (H) x 325 mm (W) x 427 mm (D)
Spectrum analyzer (HP E4902A Option 021): 279 mm (H) x 426 mm (W) x 599 mm (D)
PC: 125 mm (H) x 420 mm (W) x 390 mm (D)
Monitor: 438 mm (H) x 422 mm (W) x 410 mm (D)

Weight:

Spectrum analyzer (HP E4902A): 20 kg

**Spectrum analyzer (HP E4902A
Option 021):** 50 kg

PC: 11 kg

Monitor: 17.7 kg

Power Consumption:

HP E4902A: 440 W maximum

HP E4902A Option 021: 910 W maximum

Temperature Range: 10° to 40°C

HP E4903A Central Site Controller

System includes HP Vectra PC with UVGA monitor and pre-loaded remote control software running under MS-DOS™ and MS Windows™.

Commands HP E4900A, E4901A, or E4902A at remote site.

Option W30 two additional years return-to-HP service

Size:

PC: 125 mm (H) x 420 mm (W) x 390 mm (D)

Monitor: 438 mm (H) x 422 mm (W) x 410 mm (D)

Weight:

PC: 11 kg

Monitor: 17.7 kg

Power Consumption: 260 W maximum

Temperature Range: 10° to 40°C

Characteristics of Option 011 omnidirectional disccone antenna

Frequency Range: 25 MHz to 1300 MHz

Antenna Gain: 0 dB nominal

Polarization: vertical

Size: 1.7 meters high by 0.85 meters diameter

Weight: 1 kg

Cable Supplied: 50 feet

Cable Loss: approximately 5 dB at 1 GHz

Mounting: clamps provided to accommodate 25 to 52 mm diameter tubing

Definition of Terms

Displayed average noise level is the noise indication on a trace display using the default amplitude correction table. For this measurement, the input is terminated, attenuation is set to 0 dB, video bandwidth is 1 Hz, and the detection mode is sample. Resolution bandwidth (rbw) affects displayed average noise level. Increasing resolution bandwidth by a factor of ten adds 10 dB noise. Decreasing resolution bandwidth by a factor of ten subtracts 10 dB noise.

Third-order intermodulation product is the power level of an internal mixing product resulting from two input signals. Third-order intermodulation product is measured with two -30 dBm tones at the input, separated by at least 50 kHz.

Attenuation is set to 0 dB. The third-order intermodulation product will increase 3 dB for each 1 dB increase in the power of the input signals.

Maximum power is the maximum power that can be applied to the RF input without damage. To avoid damage, monitoring antennas should not be located near transmitting antennas unless band-reject filters are installed between the monitoring antenna and the spectrum monitoring system.

Microsoft® is a U.S. registered trademark of Microsoft Corp.

MS-DOS® is a U.S. registered trademark of Microsoft Corp.

MS Windows® is a U.S. trademark of Microsoft Corp.

Post Sales Service

To ensure your complete success, Hewlett-Packard offers extensive system support. Our global service organization keeps you up and running with local equipment service and our factory experts help you use your system efficiently. Our commitment to your success continues long after the sale is completed.

Hardware Warranty

HP E4900 systems include a standard one-year return-to-HP system warranty. Option W30 extends the warranty to three years.

Application Support

FAX Support

Our wealth of application knowledge is yours with direct access to our factory experts. FAX support is standard on every system. Typical response time is three working days.

Remote Support

To help our support team follow up on your application questions, you can demonstrate your problems using a modem and supplied remote control software. Our spectrum monitoring experts can then recommend solutions based on your specific monitoring situation.

Feature Summary Table

Table 14-5: Summary of Features

		HP E4900A	HP E4900A Option 001	HP E4900A Option 003	HP E4901A	HP E4902A	HP E4903A
Measurements							
Multiple Band Window							
	Multiple Bands	•	•	•	•	•	•
	Trace, Waterfall, Spectrogram Displays	•	•	•	•	•	•
	Markers	•	•	•	•	•	•
Spectrum Analyzer Control		•	•	•	•	•	•
Demodulation and Recording		•					
Signal Logging							
	Trace and Signal Storage	•	•	•	•	•	•
	Fixed, Noise-riding, and Profile Threshold	•	•	•	•	•	•
	Manual and Automatic Masking	•	•	•	•	•	•
Carrier Measurements							
	Center Frequency	•	•	•	•	•	•
	Maximum and Average Power	•	•	•	•	•	•
	Signal-to-Noise Ratio	•	•	•	•	•	•
	Occupied Bandwidth	•	•	•	•	•	•
	% Amplitude Modulation	•	•	•	•	•	•
	Profile Compliance	•	•	•	•	•	•
Spectral Occupancy							
	Running and Interval Occupancy	•	•	•	•	•	•
	Average and Maximum Message Length	•	•	•	•	•	•

			HP E4900A	HP E4900A Option 001	HP E4900A Option 003	HP E4901A	HP E4902A	HP E4903A
Statistical Measurements								
		Average and Maximum Channelized Power	•	•	•	•	•	•
		Fixed and Variable Threshold Channel Availability	•	•	•	•	•	•
RF Path Management								
		Amplitude Correction	•	•	•	•	•	•
		RF Path Control	•	•				
Coordination								
	Task Scheduling			•	•	•	•	•
	Multitasking		•	•	•	•	•	•
	Alarms		•	•	•	•	•	•
Remote Operation								
		Accepts remote control by HP E4903A	•	•	•	•	•	
		Controls HP E4900A, HP E4901A, and HP E4902A	•					
Reports								
	Standard Reports: text, bar graph, and line graph		•	•	•	•	•	•
	Custom Reports: data and graphics export		•	•	•	•	•	•